

S. M. Zlepko, Dr. Sc. (Eng.), Prof.; R. S. Belzetskiy; S. V. Kostyhyn

REGISTRATION OF BIOLOGICALLY ACTIVE POINTS POTENTIAL IN REMOTE CONTROL SYSTEM OF HUMAN FUNCTIONAL STATE, BASED ON Σ - Δ ANALOG – TO – DIGITAL CONVERTER

Structural diagram of remote control system of human functional state, based on Σ - Δ analog to digital converter enabling to registrate indices of biologically active points is elaborated.

Key words: telemonitoring, biological activity *биоэлектрическая активность*, registration of BAP potential, diagnostic system, functional state control.

Introduction

Development of information technologies in recent decades, widening of communication networks possibilities resulted in progress in all spheres of human activity, particularly, in medical branch. Application of telemonitoring enables to solve problems of diagnostics and control of human health state.

Nowadays, there are techniques and algorithms, allowing to enlarge functional possibilities of medical diagnostics systems and systems of telemedicine, applying the possibilities of modern telecommunication and information technologies. Intellectual information – measuring system of telemonitoring and correction of human therapy is created [1]. Main problem, dealing with the elaboration of such system is not the transmission, coding and availability of data base of biologically – active points indices (nowadays their number is sufficient), but the system of obtaining the information regarding biologically – active indices.

Main content of research

As it is known, greater part of methods of acupuncture system of human being is based on measuring of such indices BAP as electromagnetic radiation of superhigh frequency, variations of thermal sensitivity and local temperature; changes of electric resistance applying for investigation direct and alternating current [2]. Hence, the aim of the given paper is elaboration of simple, reliable and compact system intended for registration of indices of biologically – active points on human body.

In the system being developed we concentrated our attention on evaluation of functionally – energy homeostaze of the organism, defining bioelectric activity of its separate functional systems and their mutual dynamic balance.

Greater part of these points are located in the area of radial joint and foot, their location is shown in Fig 1.

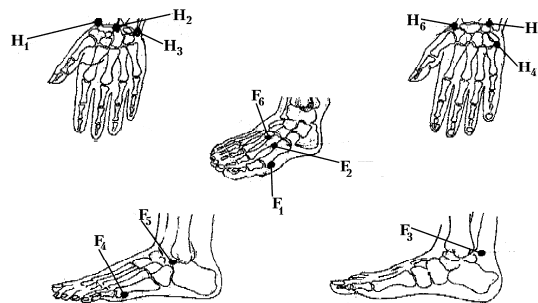

Fig. 1. Representative energy zones for diagnosis of functional – energy balance of organism

Registration of potentials of biologically active points in the system of remote control of human functional state includes the following stages:

- amplification;
- digitizing;
- noise filtration;
- compression;
- data transfer by communication channels.

Depending on the methods of solution and final aims these stages can be realized in another order and some stages can be neglected. But for complete analysis of BAP indices it is necessary to solve all above – mentioned problems. These problems as well as methods of their solution are interconnected, for instance, by means of one microcircuit amplification and digitizing can be performed, by means of one mathematical transformation filtration of noise and signal compression can be realized [3].

Primary processing of signal is the sequence of the processes, necessary for transformation of weak bio- potentials, emerging on the surface of human body as a result of BAP stimulation, into the file of digital data, for further analysis. Changes of separate signal parameter in order to define critical changes of organism state and immediate generation of alarm signal can also be referred to primary processing. The aims of secondary processing can be calculation of amplitude spectrum, image recognition, statistical analysis of the result obtained, database formation, elaboration of recommendations regarding diagnostics, treatment and sanitary procedures, etc [4].

For transformation of registered signal into its digital form by means of simple analog – to – conversation, its initial signal range being several volts, the signal has to be amplified hundreds of times. Any significant noise are not to be introduced and it is desirable that the filtrations occurs. Two variants of signal primary processing schemes by analogy with [3] are shown in Fig 2.

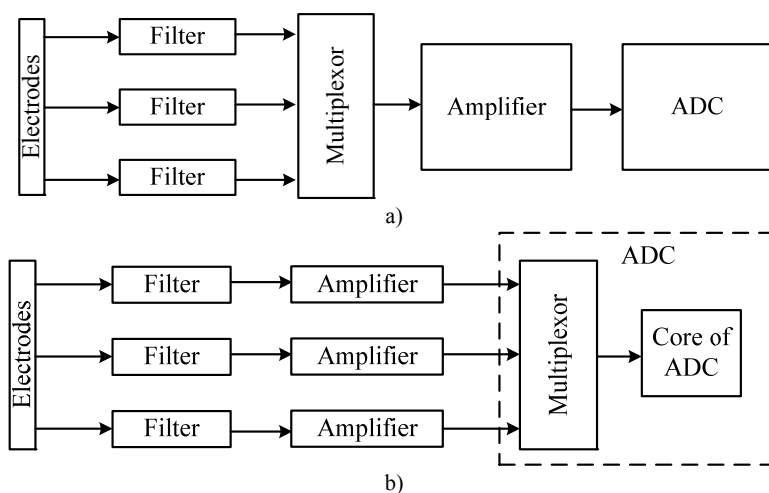

Fig. 2. Block – diagram of primary signal processing a) one channel ADC; b) multichannel ADC

In the first case, signal from various electrodes, located on BAP, enters, across filters, analog multiplexer, which switches them at the input of amplification circuit and ADC. Such construction of the system is cost efficient, regarding price, energy consumption, and small dimensions.

The drawback of the system is the necessity to pass the signal through the multiplexer prior to amplification, this result in the growth of noise. In the second case, the circuit does not possess the above mentioned drawbacks due to the fact, that each amplifier is connected to one and the same electrodes.

In the devices of primary processing of biosignals, filtration of useful signal from noise, as a rule, is performed by programming method. In our case, for programming filtration, the method of arithmetic conversion – averaging of neighbouring counts is applied:

$$S_i^* = \frac{\sum_{k=i-m/2}^{i+m/2} S_k}{m},$$

where S_k – reading of initial signal; S_i^* – reading of filtered signal; m – number of averaged readings, selected from the series 3, 5, 7.

Recently, in digital devices for primary processing of biosignals ADC, operating on the principle of $(\Sigma-\Delta)$ conversion are used. These converters perform digitizing of analog signal and considerably increase signal/noise ratio.

In considered system for realization of analog – to digital conversion $\Sigma-\Delta$ ADC 7738, manufactured by company ANALOG DEVICES are used. Application of $\Sigma-\Delta$ ADC enables to eliminate additional amplification stages. Functioning of ADC is based on the principle of redundant digitization with K coefficient and further decimation and digital filtration. [5].

$\Sigma-\Delta$ – converters comprise digital filter, which requires time interval for setting of initial code, which, in case of fast switching of channels, results in decrease of measurements accuracy.

One of the possible solutions of this problem is application 24 – digit ADC of AD 7732/34/38/39 series, enabling to enhance rate of digital conversions. AD 7738 has built – in – 8 - channel multiplexer (Fig 3) for switching of input circuits, having frequency from several hundreds Hz to 15,4 k HZ [6].

Analog multiplexer (MUX) can be configured for operation in the mode with 4 differential or 8 asymmetric inputs (AIN0 – AIN 7). Outputs of multiplexer are connected to external outputs of the element, which, if necessary, provides the possibility of additional processing of the signal by means of external functional blocks (for instance, buffer amplifier), connected to signal circuits (MUXOUT-ADCIN).

Built-in buffer amplifiers possess high performance characteristic and is used for matching variable complex load of $\Sigma-\Delta$ -converter with signal source [7].

The possibility of disconnection is provided for amplifier, in order to reduce energy consumption. The device includes built-in generator, frequency of quartz resonator being approximately 6,144 MHz, connected to outputs MCLKIN and MCLKOUT. The possibility of clocking of $\Sigma-\Delta$ modulator by external generator is provided, output signal from generator is applied to input MCLKIN.

Output MCLKOUT may be disconnected to reduce energy consumption or be used as the source of inverted, relatively MCLKIN, clock pulse.

Configuration of the given ADC parameters is carried out by means of programming set of internal register, part of them being individual for each conversion channels, whereas others, are intended for setting of mode and ADC parameters.

For communication with host microcontroller for initialization of internal registers as well as for transmission of the results to microprocessor channels CSCLK (clocking signal), DIN (data input), DOUT (data output), #RDY (data ready signal) are used..

For realization of microprocessor – based system microcontrollers, manufactured by, Atmel, Analog Devices, Intel, Microchip, Motorola, Texas Instrument, etc can be used [8]. As amplifiers

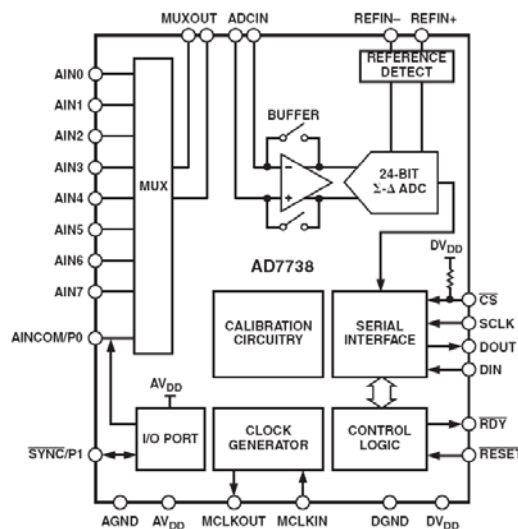

Fig 3 Structural diagram of ADC

we apply micropower precision instrumental amplifiers INA118, having differential input. They can suppress noise on 120dB at gain of 100.

Structural diagram of remote control system of human functional state based on Σ - Δ analog-to-digital converter is shown in Fig 4. Such designation are used on the diagram: H1-H6, F1-F6 – electrodes; 1 – filters; 2 – amplifiers; 3 – analog-to-digital converters; 4- microcontroller; 5 – indication unit; 6 – system start unit; 7 – cellular phone; PPC or PC,

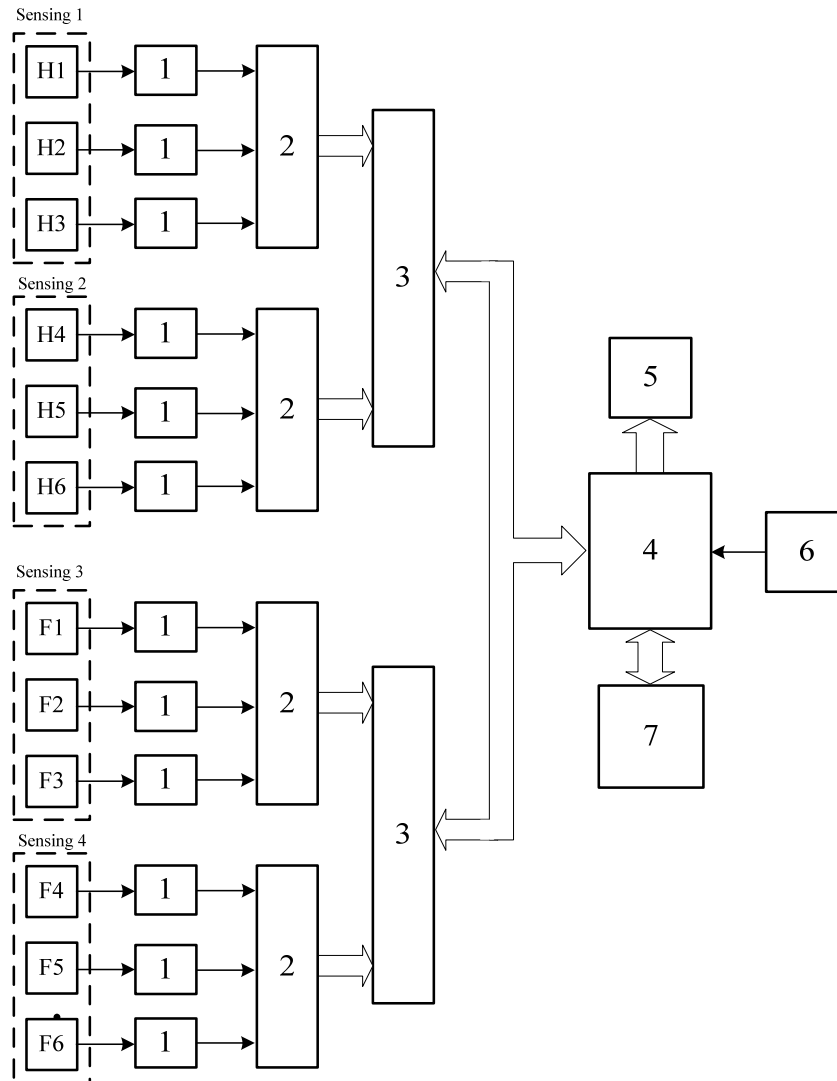

Fig. 4. Structural diagram of remote control system of human functional state on Σ - Δ АЦП

System is constantly measuring all the signals, passing from electrodes through filters 1 and amplifiers at inputs Σ - Δ of analog-to-digital converters 3, for further conversion into digital code. From Σ - Δ ADC digital code enters the input of microcontroller 4; in each operation mode the obtained information is shown on the screen of display 5. Unit 6 makes the system start operation.

For communication with cellular phone, PPC or PC – Bluetooth module is introduced in the device. The module operates on non-licensed in the whole world frequency 2,45 GHz (frequency of Industry, Science, Medicine (ISM) application) that allows to use Bluetooth freely all over the World [9].

Conclusion

Structural scheme is developed, the choice of Σ - Δ ADC remote control of human functional state is substantiated. The system allows to registrate potentials of biologically active points.

REFERENCES

1. Власюк А. І. Автоматизована віртуальна система діагностики стану організму людини / А. І. Власюк, В. І. Месюра, Б. А. Власюк // Вісник ВПІ. – 2004. – № 3. – С. 75 – 76.
2. Власюк А. І. Вибір базової медичної технології для систем телемоніторингу / А. І. Власюк, С. А. Яремко, Б. А. Власюк // Вісник ВПІ. – 2005. – № 1. – С. 69 – 74.
3. Проектирование устройств первичной обработки электрокардиосигнала для дистанционного мониторинга: [Электронный ресурс] / А. Костин, Ю. Балашов // Журнал Chip News. – 2004. – № 1. – Режим доступа: <http://www.chipnews.ru>.
4. Корневский Н.А. Проектирование электронной медицинской аппаратуры для диагностики и лечебных воздействий / Корневский Н. А. Попечителей Е. П., Филист С.А. – Курск: Курская городская типография, 1999. – 537 с.
5. Sigma-Delta ADCs and DACs. Application Note, AN-283//Analog Devices Inc. – Режим доступа: <http://www.analog.com>.
6. Mary McCarthy. Peak-to-Peak resolution versus Effective resolution. Application Note, AN-615 //Analog Devices Inc. – Режим доступа: <http://www.analog.com>.
7. Tom Meany. AD7732/AD7734/AD7738/AD7739 in low power applications. Application Note, AN-664//Analog Devices Inc. – Режим доступа: <http://www.analog.com>.
8. Чумаченко І.В. Мікроконтролерні прилади: структура і виконання: [Навчальний посібник] / І. В. Чумаченко, М. Д. Кошовий, В. В. Лопатин. – Харків: Національний аерокосмічний університет «ХАІ», 2001. – 277 с.
9. Злепко С. М. Система дистанційного моніторингу за станом здоров'я людини / С. М. Злепко, Р. С. Белзетський // Вимірювальна та обчислювальна техніка в технологічних процесах. – 2008. – № 1. С. 143 – 146.

Zlepko Sergiy – Doctor of Science (Eng), Professor, Head of the Department of medical – biological equipment design.

Belzetskiy Ruslan – Post graduate of the Department of medical –biological equipment design.

Kostyshyn Sergiy – Master of the Department of medical-biological equipment design.
Vinnytsia National Technical University