

УДК 7.046

A NEW LOOK ON PERIODIZATION OF PARTS OF MONUMENTAL ENSEMBLE OF THE ST. SOPHIA CATHEDRAL IN KYIV IN THE LIGHT OF THE LATEST STUDIES OF MOSAICS AND FRESCOS IN THE DOME-SPACE

Yurii Koreniuk

Ph.D. in Arts, Senior Research Fellow, Department of Museology and Monumental Studies, Institute of Culturology of National Academy of Arts of Ukraine

Корениук Юрій Олександрович

кандидат мистецтвознавства, доцент, старший науковий співробітник відділу музеєзнавства та пам'яткознавства Інституту культурології НАМ України

Корениук Юрий Александрович

кандидат искусствоведения, доцент, старший научный сотрудник отдела музееведения и памятниковедения Института культурологии НАИ Украины

Roman Hutsuliak

Ph.D. in Chemical Sciences, Head of the 'Golden Gate' Museum Segment of National Sanctuary Complex 'Sophia of Kyiv', Member of Ukrainian National Committee 'ICOMOS'

Гуцуляк Роман Борисович

кандидат хімічних наук, завідувач сектору музей «Золоті ворота» Національного заповідника «Софія Київська»; член УНК ICOMOS

Гуцуляк Роман Борисович

кандидат химических наук, заведующий сектором музей «Золотые ворота» Национального заповедника «София Киевская»; член УНК ICOMOS

Natalia Shevchenko

Senior Research Fellow of the Research Department of Physical and Chemical Researches of National Research and Restoration centre of Ukraine

Шевченко Наталія Олександрівна

старший науковий співробітник наукового відділу фізико-хімічних досліджень Національного науково-дослідного реставраційного центру України

Шевченко Наталья Александровна

старший научный сотрудник научного отдела физико-химических исследований Национального научно-исследовательского реставрационного центра Украины

Summary. The article deals with the results of the researches of mosaics and frescoes in the northern part of under-dome space of Saint Sophia Cathedral in Kyiv held during the conservation in 2013–2014. It revealed that the mosaic ornamental friezes' plaster on the north-western under-dome column covered fragments of frescoes that had existed on this pole before they were decorated with mosaics. During sensing and sampling plaster bases of mosaics in the northern under-dome space, the lower layer of fresco plaster was discovered under them in several places. This gave the rise to the conclusion that the mosaics in under-dome space are not the primary decoration, at least not all of them. On the first stage of designing the temple's interior the under-dome space was painted with frescoes to the top, which were later replaced with mosaics, although not completely. Considering such a conclusion, the fragments of fresco medallions of the Martyrs of Sebaste preserved on the western arch should not be considered as an unfinished mosaic fresco ensemble complement. They should be considered as the remains of the previous fresco paintings that in the western arch were not replaced with mosaics for some reason as it was done in three other arches. It is possible that simultaneously with the replacement of primary frescoes with mosaics in the under-dome space such change was made in some areas on the walls of the presbytery. However, confirming or refuting this assumption needs detailed probing of all the presbytery walls, which was not yet done.

Keywords: St. Sophia Cathedral in Kyiv, mosaic, fresco, mural painting, plastering mortar, filler mortar

Erected in the first half of the 11th century, St. Sophia Cathedral in Kyiv was the largest church in Eastern Europe. The decoration of its interiors was the largest artistic ensemble of the Christian world of the time in the East and the West¹. The central dome, the upper part of the dome space and the main altar of St. Sophia were decorated with mosaics; primarily they covered, according to estimation, 640 sq. m., (260 sq. m. are now preserved). Frescoes covered all other parts of the cathedral's five-nave core, including space in the choir, the inner and outer galleries, corridor staircases of two towers leading to the choir. The primary area of frescoes in all parts of the interior reached 6000 sq. m. (nearly 3,000 sq. m. preserved as of today).

The core of dogmatic images' system of the St. Sophia mosaic ensemble is the waist-height image of Christ the Pantocrator in the central dome (fig. 1, 2.1). It is surrounded by four archangels.



Лл. 1. The mosaic decoration of the dome, the under-dome space and the altar.

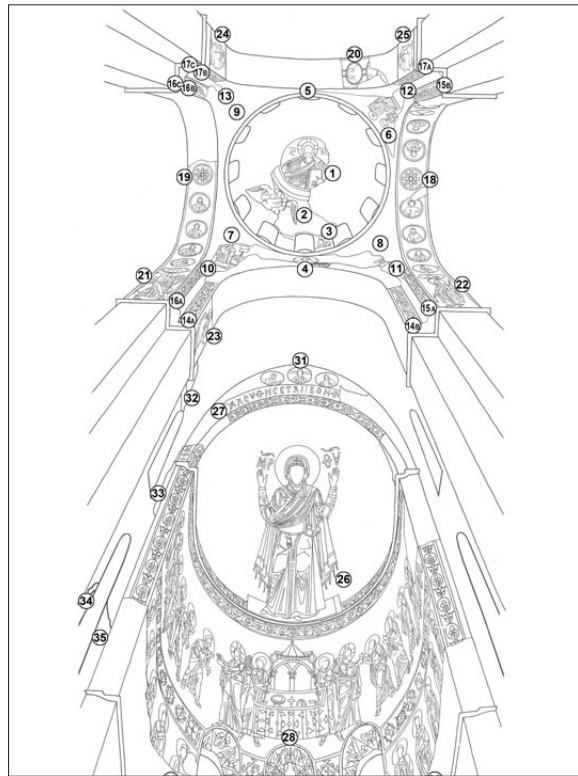

Лл. 2. The cartogram of the position of mosaic in the dome, under-dome space, altar, and the remains of the frescoes in upper zone of the under-dome space and in the altar.

Only one figure of the archangel preserved (fig. 1, 2.2), the others were lost and completed with an oil paint, as well as the figure of Virgin Oranta praying to Christ (fig. 1, 2.26) depicted in the conch of the apse of the main altar. Along the conch arch the fragments of the inscription (fig. 1, 2.27) are preserved with the poem from the Book of Psalms (45:6), which tells about the eternal and undestroyable city where the God dwells. Thus, the image of the Virgin who bears the incarnate Son of God had a meaning of Palladion protecting the temple, the city, and the kingdom. The theme of intercession and protection is developed by the waist-height “Deësis” (the Threemorphon) in three medallions placed in the lunette over the conch arch (fig. 1, 2.31).

The image of Christ the Pantocrator in the main dome is thematically linked to the images of the dome drum. In St. Sophia in the drum between the twelve windows were depicted the figures of the Twelve Apostles (only the upper part of the figure of the Apostle Paul (fig. 1, 2.2) preserved, the other apostles were destroyed and added with an oil paint). The choice of such a programme of dome decorations testifies the topicality of apostolic sermon and the spread of the gospel

doctrine in the recently baptized state. It continues in the pendentives (angle vaults of under-dome ring) with the figures of the evangelists who write the Gospels (only the figure of Mark the Evangelist (fig. 1, 2.6) is fully preserved; the figure of John is preserved in the fragment (fig. 1, 2.7); the images of Matthew and Luke (fig. 2.8, 2.9) were lost and over-painted with an oil paint). Between the pendentives over the keystone parts of the under-dome arch, medallions were placed. There are still two preserved medallions: the medallion with a waist-height image of Christ above the eastern arch (fig. 1, 2.4, 20) and the fragment of the medallion with the Virgin Mary above the western arch (fig. 1, 2.5). The complex of these images is united by the theme of the Incarnation and located on the border between the highest zone of the temple interior and the main altar developing the idea of a connection between the Church of Heaven and the Church of Earth. Meanwhile, Christ above the eastern arch, represented in a rare iconographic image of Christ the Priest, is included in the cycle of liturgical images.

The main plot of the liturgical programme is presented in the middle register of the hemisphere of



Лл. 3. The bema, the northern wall with fragments of mosaics in the upper part and frescos fragments in the lower part; the northern surface of the altar arch with the mosaic image of the high priest Aaron.

the apse wall by "Eucharist" (fig. 1, 2.28) depicting the eternal Heavenly liturgy and symbolizing the unity of the Church of Heaven and the Church of Earth. In beneath register, the similar meaning is embodied by figures of eight holy bishops and two archdeacons (fig. 1, 2.29, 2.30) surrounding on both sides the communion table located in the middle of the altar. Two Old Testament high priests, depicted on the inner pilasters of the altar arch nearly at the same level as the "Eucharist" in the apse (only the figure of the high priest Aaron on the northern pilaster preserved (fig. 2.23, 3)), are the prototypes of Christ, the High Priest of the New Testament depicted in this scene. Together with the register of the holy bishops (the Church Fathers), they indicate the hereditary connection between the Old Testament and the New Testament priesthood.

On the western pilasters of the altar arch pillars (the eastern pair of under-dome pillars) entering the under-dome space, the characters of the "Annunciation" scene are depicted in the same register as the high priests: Archangel Gabriel (fig. 1, 2.21, 4) on the pilaster of the north-eastern pillar and the Virgin Mary (fig. 1,

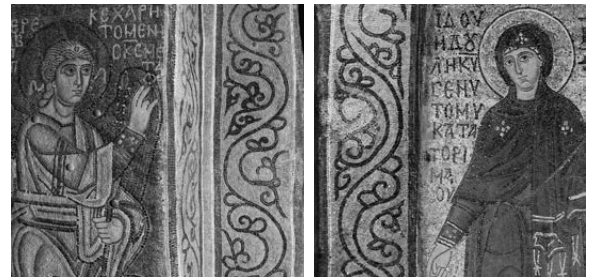

Лл. 4. The north-eastern pillar; the figure of Archangel Gabriel of the "Annunciation"; alongside on the southern pilaster of the pillar is ornamental frieze of the eastern under-dome arch.
Лл. 5. The south-eastern pillar; the figure of the Virgin Mary of the "Annunciation"; alongside on the northern pilaster of the pillar is ornamental frieze of the eastern under-dome arch.

2.22, 5) on the pilaster of the south-eastern pillar. The Annunciation is the first story of the Twelve Great Feasts, which are continued on the vaults of the arms of the transept and the central nave. All these compositions were depicted in frescoes, but none of them have been preserved till nowadays. Meanwhile, the frescoes with scenes of the gospel cycle are preserved to a greater or lesser extent on the walls of the arms of the transept.

A series of images of the Forty Martyrs of Sebaste covered the slopes of the four under-dome arches. On both slopes of each arch, there were five medallions with waist-height depictions of the martyrs. In a keystone part of each arch, a medallion with the eightfold cross was placed. All of these medallions have been preserved in the southern arch (fig. 1, 2.18). Five mosaic medallions with martyrs and the medallion with a cross have been preserved on the northern arch (fig. 1, 2.19, 6). The mosaic on both of slopes of the eastern arch has crumbled. On the southern slope in the western arch, the fragment of frescoes with the remains of two medallions with the martyrs have been preserved (fig. 2.20, 7), indicating that the Martyrs of Sebaste in this arch were not mosaic, but painted with fresco.

In addition to the main dome, the upper part of the under-dome space and the altar apse, mosaics decorated the bema (the space between the apse and the altar arch). However, only two small mosaic fragments located in the upper part of the northern wall were preserved. One of them is with slight rests of an ornament and an unknown plot composition (fig. 2.32, 3). Another fragment preserved along the apse ledge only with a remnant of a background (fig. 2.33, 3, 21). Also, fragments of fresco painting depicting the remains of a figure of a saint (fig. 2.34, 3) and a part of an ornament (fig. 2.35, 3) were preserved in



Лл. 6. The northern under-dome arch, eastern slope, the medallion with Leontius, the Martyr of Sebaste.



Лл. 7. The western under-dome arch, a fragment of a fresco with the remnants of two medallions with Martyrs of Sebaste.

the lower part of this wall. These fresco fragments indicate that frescoes decorated the lower parts of the bema walls. The boundary between the mosaic decoration of the upper parts of the bema walls and the frescoes of the lower parts was at the same level as the boundary between mosaics and frescoes in the under-dome space. It can be determined by the mosaic fragment preserved close to the apse ledge (fig. 2.33, 21). This level corresponds to the height of the floor of the choir and is noted on the pilasters of all under-dome pilasters. However, these cornices do not extend to the bema walls.

The descriptions of St. Sophia, as well as its mosaics and frescoes, were published in the 19th century [1; 2, 64–68; 3, 787–805; 6, 235–260; 17, 111–160]. In the 1960s V. Lazarev proposed the sequence of stages of the creation of the mosaic and fresco ensemble of St. Sophia into several periods. According to V. Lazarev, the initial phase was the creation of mosaics after which painting of the interior with frescoes started. He divided them into phases corresponding to two St. Sophia consecrations in 1046 and 1061 (or 1067). Meanwhile, the frescoes of external galleries and of two towers leading to the choir he dated as the period of the reign of the Prince Volodymyr Monomakh in Kyiv (1113–1125) [7, 161–165; 8, 55–57]. The grounds for such dating of frescoes in exterior parts of the building were the findings of researchers of St. Sophia's architecture of those days. They considered its exterior gallery and two staircase towers to be building's extensions at the end of the 11th — at the beginning of the 12th century since their masonry is not tied to the masonry



Лл. 8. The resonator holes: in the north-eastern pendentive (on the left); in the south-eastern pendentive (on the right).

of internal galleries [4, 118–129, 166–172].

However, in the 1970s thesis of a significant time break between the construction of the central core of St. Sophia and its external galleries and towers was reasonably refuted. It turned out that in some places the sections of the fresco plaster of the internal galleries overlap the previously executed frescoes of the external galleries, which evidenced an approximate simultaneity of the performance of the paintings of external and internal galleries [14; 15, 177, 178, 183]. Moreover, the studies of grouts of fresco plaster bases showed that in the five-nave core of the cathedral, in its interior and exterior galleries, and in the staircase towers, the grouts of fresco plaster have the same composition of mineral fillers [16, 196–199, tab. 1, 2; 18, 184 – 190]². After that, the need to divide the St. Sofia fresco ensemble into parts separated by the long-term breaks in execution has disappeared. V. Lazarev's concept of phase division of frescoes creation in the five-nave core of the Cathedral corresponding to two consecrations began to be perceived as artificial. However, his thesis that the performance of frescoes of St. Sophia began only after the completion of works on mosaics [8, 26, 38, footnote 4; 9, 65] remained unchanged at that time. Nevertheless, there was a tendency to separate phases of work on the mosaic ensemble.

In the late 1950s, V. Levytska, while exploring the palette and techniques of mosaic sets in St. Sophia, proposed the following sequence of their execution: at the first phase, the mosaics of the vault of the dome and the upper part of the apse were set; at the second phase, the scaffoldings were lowered to the level of the drum of the dome and the bottom of the apse; at the same time works in the bema and in the altar arch began; at the third phase they moved to the under-dome part, the northern and southern under-dome



Іл. 9. The resonator hole and images of two crosses in the north-western pendentive



Іл. 10. The south-western pillar; the ornamental frieze of the western under-dome arch, the southern part.



Іл. 11. The north-western pillar; the ornamental frieze of the western under-dome arch, the northern part.



Іл. 12. The south-eastern pillar; the ornamental frieze of the southern under-dome arch, the eastern part.

arch, which had completed the mosaic setting [10, 182, 183]. V. Levyt'ska also noted that some parts of the set in the golden background of the under-dome ring were made of differentiated modules of smalt, which evidenced the usage of remnants of a set material at the completion phase [10, 178]. The same can explain the replacement of golden smalt with yellow one in the clothing on most images of Martyrs of Sebaste, located on the under-dome arch [11, 132; 12, 126].

In 1989–1990 during prophylactic conservation of mosaics of the central dome and the under-dome space in St. Sophia (supervised by A. Ostapchuk), restorers noticed the significant differences in the design of resonator holes located in the pendentives. In the eastern pair of pendentives, both resonator holes are decorated with polychrome ornamental disks similar to plates (fig. 1, 2.10, 2.11, 8). Meanwhile, resonator hole in the south-western pendentive (fig. 2.12) is bordered by almost monochrome green-blue disc on a green background. In the north-western pendentive, the resonator hole is surrounded only by one row of white stones and one row of red cubes of smalt. However, the featured detail of the north-western pendentive is two small votive-like crosses below the resonator hole set in a red and blue smalt (fig. 2.13, 9).

No less notable differences are demonstrated by ornamental friezes that decorated the circumferences of four under-dome arches and descended on the lateral facets of pilasters of under-dome pillars from the arch bases to the level of cornices, which corresponds the level of the choirs' floor. All these ornaments have

been preserved mainly in vertical sections located on the pilasters (fig. 1, 2.14, 2.15, 2.16, 2.17), while their upper parts along the arches' slopes were cut down apparently in the 17th century.

In all four arches, friezes represent ribbon-vegetable motive of the “byzantine vine” (wavy-curved central stem with side branches), though, their execution varies on eastern and western pairs of pillars. The sections of ornamental friezes remained on the pillars of the eastern (altar) arch have a yellow ornamental field with the stem and branches composed of emerald-black or black smalt (fig. 1, 2.14a, 2.14b, 4, 5). Meanwhile, the western arch frieze has considerably longer bends of the waves of the central stem. Its ornamental field is filled with olive smalt, the stems in the area that remained on the south-western pillar are set in with blue smalt, which is hardly distinguished on the olive background (fig. 2.17a, 10). On the section of this frieze preserved on the northwestern pillar, the stems are mostly set in with black smalt, which was only partially replaced by dark blue one. The background, in this case, is filled with smalt of several dark-olive and light-olive shades mixed randomly (fig. 2.17b, 11, 17, 18). The frieze of the southern arch, in the part preserved on the southeastern pillar, has a yellow background of the ornamental field. It is the same as in the part of the frieze of the eastern arch located on this pillar, the stems set in on this yellow background with a dark emerald smalt there (fig. 1, 2.15a, 12). The part of this frieze preserved on the south-western pillar has an olive background of the ornamental field similar to the southern section of the

ornamental frieze of the western arch located on this pillar, and for the stems mainly the emerald-black smalt is used there (fig. 2.15b, 13, 19). The northern arch frieze, in part preserved on the northeastern pillar, has a yellow background of the ornamental field as in the part of the eastern arch frieze located on this pillar, with the stems set in on a yellow background with a saturated green smalt (fig. 1, 2.16a, 14). The background of the ornamental field of the part of this frieze preserved on the north-western pillar filled with a colorful mixture of brown, green, dark-olive and light-olive shades of smalt supplemented with a light-grey stone in some areas. The stems in the upper part of this preserved area are set in with an emerald-black smalt, while lower part stems are of a pure black setting alternating with the blue one in some places. In the highest part of the fragment both background and stems are set in standard cubes for Sophia mosaics of 5x5, 5x7 mm. Meanwhile, beneath, the smalt is punctured irregularly with the mainly large-scale module (10x10 mm or bigger), the cubes are laid with different gaps, and, in general, the set looks negligently (fig. 2.16b, 15, 16). A similar large-scale module of smalt and rather negligent technique is the characteristic of the northern section of the frieze of the western arch located on this pillar (fig. 11, 18).

Considering the above-mentioned differences in the design of the resonator holes in the eastern and western pairs of pendentives and no less significant difference in the fragments of ornaments preserved on the eastern and western pairs of pillars, the restorers expressed the point of view that the mosaic fragments in the lower parts of the western pair of pendentives (from the level of slightly higher than resonator holes) and the western pair of under-dome pillars belong to the latest phase of mosaic ensemble creation. However, the boundary between the sections of the earlier and the final phase of execution was not identified completely as the upper parts of the ornaments were lost on all arches, as well as a continuous loss observed over the resonator in the north-eastern pendentive (fig. 9).

The following conservation of mosaics in the dome space of St. Sophia was held in 2013-2014. It encompassed northern part of the under-dome ring along with the north-eastern and north-western pillars as well as a part of the south-western pillar to the level slightly higher than the floor of the choirs. Technological observations of this period have confirmed all previous findings, complementing them with some new important data.

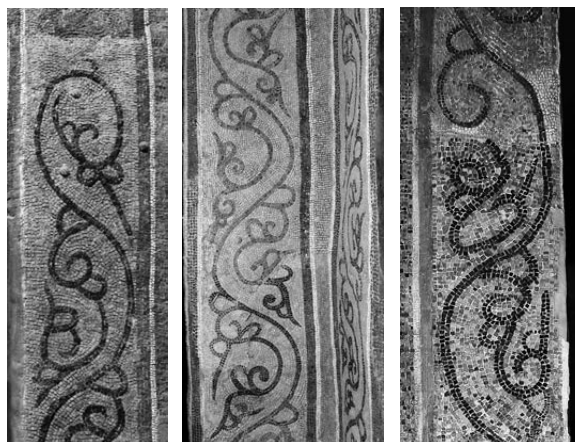

Лл. 13. The south-western pillar, the ornamental frieze of the southern under-dome arch, the western part.

Лл. 14. The north-eastern pillar, the ornamental frieze of the western under-dome arch, the northern part.

Лл. 15. The north-western pillar, the ornamental frieze of the northern under-dome arch, the western part.

After removing the restoration painting over the cornice of the north-western pillar, the preserved fragments of frescoes were revealed. These frescoes were made before the appearance of its mosaic decoration. A set of mosaic ornamental friezes located on the lateral facets of the pilaster of this pillar (the western part of the frieze of the northern arch and the northern part of the western arch), does not reach the cornices for 0.95 — 1.20 m (fig. 2.16b, 2.17b). Below there are small sections of the mosaic plaster deprived of the set and with only the fresco under-layer. Lower, the well-preserved remnants of the fresco painting are situated, which were later replaced by mosaic decoration. Above the cornice plates, fragments of non-spilled original frescoes of 0.50–0.65 m of height were preserved (fig. 2.16c, 2.17c). On the eastern pilaster of the pillar, the mosaic plaster of the ornamental frieze is adjacent to the cut edge of the fresco plaster in the junction (fig. 16). While on the southern pilaster, a mosaic plaster of the ornamental frieze overlaps a fresco plaster with a layer of 1–2 cm of thickness (fig. 17, 18). Consequently, it is obvious that the mosaic on the north-western pillar appeared later than fresco paintings.

The cleared fragments of frescoes above the cornices of the north-western pillar obviously belong to the first phase of the decoration of the under-dome space. They retained the remnants of the panels similar to that located in the fresco ensemble of St. Sofia in the lower parts of walls and pillars above the surface of the ground floor and above the surface of the choirs' floor,



Лл. 16. The north-western pillar, the lateral facets of the eastern pilaster, the fragment of the fresco panel, partly covered by the mosaic ornamental frieze.



Лл. 17. The north-western pillar, the lateral facets of the southern pilaster, the fragment of the fresco panel, partly covered by the mosaic ornamental frieze.



Лл. 18. The north-western pillar, the southern pilaster, the fresco panels on its frontal and lateral facets, the mosaic ornamental frieze on the lateral facet partly overlaps the fresco panel below.



Лл. 19. The south-western under-dome pillar, the north pilaster, a fresco figure of an unknown martyr and a panel below it.

as well as on the pilasters of the western pair of the under-dome pillars over cornices corresponding to the level of the choirs' floor. The decoration of both panels opened above the cornice of the north-western pillar is typical for lateral facets of pilasters and represents the simplest version of the pictorial imitation of the polyrite (wall covering with coloured marble) depicted in the form of monochromatic painted rectangles surrounded by a simple fringe. The fragment of the panel located on the lateral facet of the southern pilaster is connected through its facet edge to the panel on the frontal facet of the pilaster, which imitates the "opus sectile" (wall ornamentation with coloured marble), a type of decoration using paint. This panel has been preserved to its full height (*fig. 18*) along with the fresco figure of the martyr above it (*fig. 2.24*). Research of the joints of plaster areas of the frontal and lateral facets' frescoes on the pilasters shows that frontal facet was painted before lateral one. It is so since the plaster of lateral panel intervene the plaster of the frontal facet of the panel, while the fresco of the lateral facet was later overlapped with the plaster grout of the ornamental mosaic frieze.

The frontal facets of the symmetrical pilasters on the south-western pillar also preserved the figure of the martyr and the panel underneath (*fig. 2.25, 19*). Mosaic ornamental friezes on the lateral facets of the pilasters of this pillar also do not reach the cornice. During sondage of over-paintings covering the areas with the missing mosaic set, on both pilasters, the insertions of the late plaster were revealed under the paintings. This plaster adjoins from above a mosaic plaster with

the remnants of the layer of the fresco plaster beneath (fragments of the previous frescoes on this pillar were destroyed, obviously, with the application of the later plaster). The study of the junction points of the mosaic ornament of the lateral facet of the pilaster on the south-western pillar with a preserved fresco figure on the frontal facet showed the same picture as on the pilaster of the north-western pillar. Originally, a fresco was performed on the frontal facet of the pilasters, then on its lateral facet, where a mosaic later replaced the fresco. Thus, both the frescoes of the martyrs on the frontal facets of the pilasters on the western pair of under-dome pillars, and the fresco medallions with waist-height depictions of the Martyrs of Sebaste on the slopes of the western arch above them, were executed earlier than the ornamental mosaic friezes on the lateral facets of the pilasters on this arch.

During the conservation works in 2013–2014 scientific and technological types of research of plaster bases of mosaics and frescoes in under-dome space were carried out. They showed that all frescoes, including those above the cornices, which mark level of the choirs' floor on under-dome pillars (the zone of preferential placement of mosaic decorations) and those below the cornices, where no mosaics appear, are made on two-layer plaster bases of lime grout of nearly the same composition. As mineral filler of both layers, a finely powdered ceramic (tsemianka), made from burnt loess loam (*fig. 23*), and similarly powdered slag (burnt and half-done glass) (*fig. 24, 25*) were used. The total share of mineral fillers in both layers does not



Іл. 20. The under-dome ring, the medallion over the eastern arch with image of Christ the Priest. A light rectangle below the cornice is probe with the remnants of the fresco plaster.

exceed 30% of the grout mass. The organic admixtures in both layers are cut stems from a straw and chaff. Such a composition was identical to the composition of samples of fresco plaster selected in the process of the mentioned studies of the 1970s in the five-nave core of the cathedral, in its internal and external galleries, and in the staircase towers [16, 196–199, *tab. 1, 2; 18, 184–190*].

Mosaics were set mainly on three-layer plaster bases, although there are two-layered ones. However, no constant patterns in the application of triple-layer and double-layer versions were found, the location of the probes with three-layered and two-layered variants are pointed on the cartogram (*fig. 22. №1M-9M*). The composition of the lower levelling layer of a mosaic plaster is similar to the mural grouts of walls; here the filler was a crumb and powder ceramic, made from loess loam reaching 50% in the volume of grout. Meanwhile, the two upper layers (or one layer) contain a small amount of slag such as a mineral filler of a fresco plaster mortar. However, both top layers of mosaic plaster do not contain ceramic crumb made of a burnt loess loam being the identifying attribute of fresco grouts. A sliced straw and chaff are added to the lower and middle layer of a mosaic plaster. In the upper layer, they are contained in a much smaller quantity or absent at all, since they complicate a set execution.

Thanks to these identifying attributes, which make it possible to distinguish between grouts of mosaic and fresco plasters, a few places with mosaic covering the remains of fresco painting were discovered in addition to fragments of fresco panels that have been preserved



Іл. 21. Bema, the northern wall, the fragment of a mosaic with an underneath and a background, near with the mosaic ornament on the apse ledge.

on the north-western pillar (*fig. 16 — 18, 22.№15F*). At the same north-western pillar, along with the edge of its eastern pilaster, the mosaic plaster intervene the remnants of the red ochre fresco-fringing of the lost image on the frontal facet of the pilaster (*fig. 22.№11M/F*). Regarding this, it is worth paying attention to the information of V. Lazarev, who wrote, referring to the study of restorers of the 1950s (no particular source was pointed out), that the mosaic decoration on the western slopes of the northern and southern under-dome arch was limited by their bases (lower medallions with images of the Sebaste martyrs), below which the pilasters on the pillars were painted with frescoes [9, 65]. Therefore, mosaic ornaments on the pilasters of the western pair of pillars appeared not only later than fresco figures under the western arch, but also later than frescoes that existed on the pilasters under the western slopes of the northern and southern arches. Now the frontal facets of these pilasters are covered with oil paintings on the plaster of the 19th century. During the sondage of the pilaster of the north-western pillar in 2013, the remains of the ancient plaster were not found. Another area with remnants of fresco plaster covered with a mosaic grout and set exists alongside the lower image of the cross located beneath the resonator hole in the north-western pendentive (*fig. 9, 22.№10M/F*). It evidences that not only the vertical parts of the pilaster, but also the pendentive were originally painted with frescoes, and their mosaics belong to the later phases of interior decoration. A few analogous places where the mosaics decorations covered the plaster of previous frescoes were also discovered on the south-western pillar (*fig. 22.№13M/F, №14M/F*).

There are grounds to make a similar conclusion for the whole under-dome ring. Beneath the base of the dome drum under the cornice on the narrow strip of plaster without a mosaic set somewhat north to the medallion with the image of Christ the Priest two layers of fresco plaster, which do not overlap with the grout of

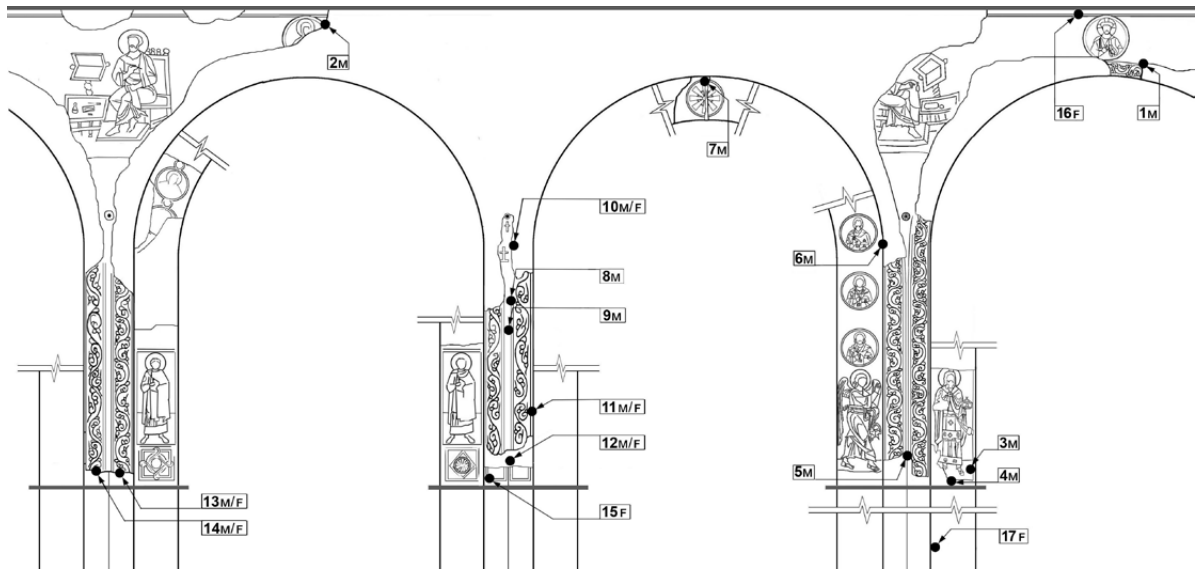

Лл. 22. The cartogram of the samplings of mortars of mosaics and frescoes plasters in the under-dome space in 2014 (after the sample number, the index "M" — a mosaic plaster, the index "F" — a fresco plaster, the index "M / F" — mosaic mortar, which overlaps the bottom layer of fresco mortar).

the mosaic plaster, were discovered (fig. 20, 22.№16F). This is obviously the remnants of the previous frescoes of the under-dome ring. Before being replaced with mosaics, they were put down. However, they partially preserved under the cornices, where the removal of the plaster basis was complicated.

Summing up the listed results of technological observations over various parts of the mosaic settings in the under-dome space and results of analytical studies of the samples of plaster bases of mosaics and frescoes, the following general conclusions were made.

1. The mosaics of the under-dome space do not belong to the first phase of interior decoration of St. Sophia (if they do, then not all of them). At the first phase of the decoration of temple's interior space the whole under-dome space (or maybe its part) was painted with frescoes, which were partially replaced with mosaics to the level of cornices of under-dome pillars.

2. Considering the first conclusion, the fragments of fresco medallions of the Martyrs of Sebaste preserved on the western arch (fig. 2.20, 7) should not be considered as an unfinished mosaic fresco ensemble complement (as V. Lazarev assumed [8, 38, footnote 4, 125; 9, 65]). They should be considered as the remains of the previous fresco paintings that were not replaced by mosaics.

3. Frescoes from all parts of St. Sophia, including

the previous paintings of the upper zone of the under-dome space, where later they were almost completely replaced by mosaics, as well as exterior galleries and staircase towers of the cathedral, are the work of one or several genetically linked groups of masters who worked without significant time breaks following a single technological tradition. The same composition of mineral fillers of fresco plaster grouts in all parts of the temple proves it.

4. The preparation technology of mosaics plaster, which replaced more early frescoes in the under-dome space, is the same. However, some parts of the mosaics in this space demonstrate variations in some plaster layers (two or three), different smalt palettes, and different set techniques. It may be explained by the participation of different groups of workers. At the same time, some colouristic features of images in the dome space obviously related to a deficiency of certain kinds of smalt during the completion phase of works. It concerns especially gold one, which was replaced with yellow on many images located here. In some areas of golden background, modules of smalt of different size and of poor quality were laid, losing afterward its cantarell (a thin top layer glass protecting the gold foil) together with gold foil. The deficiency existed in some varieties of chromatic smalt, including yellow one, which was replaced with olive or random colours in ornaments of a western pair of under-dome pillars (fig.

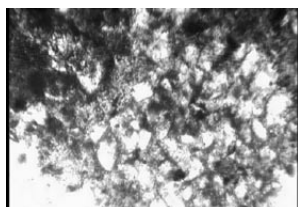

Лл. 23. A fragment of ceramic (tsemyanka), produced by burning of loess loam in mortar. A thin micros-section of plaster mortar in polarized light (10x objective zoom).

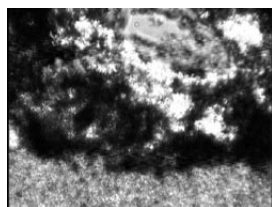

Лл. 24. A fragment of burnt glass (slag) in mortar. A thin micros-section of plaster mortar in polarized light (10x objective zoom).

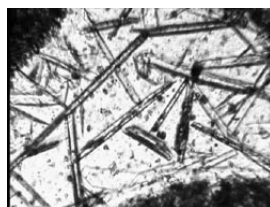

Лл. 25. A fragment of unstable glass with a new formation (slag) in mortar. A thin micros-section of plaster mortar in polarized light (10x objective zoom).

10, 11, 13, 15, 18, 19). This fact is likely to explain the cessation of works to replace frescoes in the dome space with mosaics, which ended before reaching the western arch.

5. The conclusions of the previous paragraph confirmed the thesis proposed by V. Levytska that mosaics of the under-dome space belonged to the last phase of works on St. Sophia's mosaic ensemble [11, 183]. At the current stage of research, this argument complemented by new data showing that it was the phase of the partial replacement of already existing decorations of temple's interior when mosaics replaced earlier fresco paintings.

2013–2014 restoration works did not cover the altar bema space. However, from scaffolding installed in the altar arch, it was observed that one of mosaic fragments preserved on the northern wall of the bema near the apse ledge (fig. 2.33) was set in with a smalt of a slightly larger module than the smalt of ornamental frieze on the apse ledge next to it. Moreover, on the part of the background of this fragment, an olive smalt was set instead of a traditional gold one. This feature was overlooked by V. Lazarev, who, about this fragment, wrote that over the yellow and green strips of its underneath "the remnant of the golden (our selection) background had been preserved" [8, 94]. In reality, smalt on the background of the fragment is of an olive-grey tint (fig. 3, 21), similar to the one set in a background of the ornamental friezes on the south-west under-dome pillar (fig. 10, 13, 19). The same smalt

was also used to set in the background of ornamental friezes on the north-western under-dome pillar, where it is supplemented with a few completely dark olive shades and a few lighter ones (fig. 11, 15, 18). Now we know that on the north-western pillar, the areas of these ornaments overlap the earlier frescoes (fig. 16–18,

22..№11M/F-12M/F). Consequently, it arises an idea that the mosaic fragment located near the apse ledge, being the remnant of the lower case of bema mosaic images, may also belong to a later stage of decorations when mosaics replaced a part of the preceding bema frescoes. Though, to confirm this assumption, detailed studies of all non-examined bema walls are required.

Finally, we should mention the hypothesis expressed in the 1990s by I. Totska, who drew attention to the non-standard character of the masonry in decorative niches on the external wall of the central apse of St. Sophia. She suggested that initially, these were not niches, but the windows that were later laid down to obtain the additional area necessary for placing the scene of "Eucharist" (the scene with Communion of the Apostles) in the apse [19]. I. Totska's idea was developed by A. Lidov. He put forward a hypothesis according to which "Eucharist" was not a part of the first programme of the St. Sophia's altar decoration. It appeared in times of the Metropolitan Ephraim (1054/55–1065) when the "Communion of the Apostles" acquired relevance in controversy between Byzantine and Latin theologians regarding Eucharistic bread, which was particularly acute on the eve of the schism of the Eastern and the Western Churches (1054). [13, 164, footnote 2]. Nowadays, we have no evidence to confirm this hypothesis, though, in the light of recent studies of the St. Sophia's under-dome space, further research in this direction seems to be promising.

Примітки:

1. The chronicles of the time of the construction of St. Sophia are contradictory. "The Tale of Bygone Years" writes about it being founded by the Prince Yaroslav the Wise in an article for year 1037. The older edition of the Novgorod First Chronicle wrote the year 1017 as the year of St. Sophia foundation. The earlier edition of Novgorod First Chronicle repeats the date of its foundation, while indicates 1037 as a year of the completion of construction.

2. The fact of the phased construction of internal and external galleries was not denied finally, but the chronological limits of the appearance of these parts were narrowed. Most researchers agreed that all parts of St. Sophia Cathedral along with their fresco paintings were completed during the life of the customer, Prince Yaroslav the Wise, before 1054. A general analysis of all concepts and points of view on this subject was provided by O. Komech [5, 200–208].

The titles of the illustrations:

1. The mosaic decoration of the dome, the under-dome space and the altar.
2. The cartogram of the position of mosaic in the dome, under-dome space, altar, and the remains of the frescoes in upper zone of the under-dome space and in the altar.
 - 2.1. The vault of the main dome with Christ the Pantocrator in the medallion
 - 2.2. The main dome vault with the figure of Archangel (fragment).
 - 2.3. The drum of the dome, the figure of Apostle Paul (fragment).
 - 2.4. The under-dome ring, eastern part, Christ the Priest in the medallion.
 - 2.5. The under-dome ring, western part, the Virgin Mary in the medallion (fragment).
 - 2.6. The south-western pendentive, the figure of Mark the Evangelist.
 - 2.7. The north-eastern pendentive, the figure of John the Evangelist (fragment).
 - 2.8. The south-western pendentive, the figure of Matthew the Evangelist (mosaic image of the figure is lost, only the table is preserved).
 - 2.9. The north-western pendentive, the figure of Luke the Evangelist (the mosaics image is entirely lost).
 - 2.10. The resonator hole in the north-eastern pendentive.
 - 2.11. The resonator hole in the south-eastern pendentive.
 - 2.12. The resonator hole in the south-western pendentive.
 - 2.13. The resonator hole and the images of two crosses in the north-western pendentive.
 - 2.14a. The ornamental frieze of the eastern under-dome arch (altar arch), the northern part on the north-eastern pillar.
 - 2.14b. The ornamental frieze of the eastern under-dome arch (altar arch), the southern part on the south-eastern pillar.
 - 2.15a. The ornamental frieze of the southern under-dome arch, the eastern part on the south-eastern pillar.
 - 2.15b. The ornamental frieze of the southern under-dome arch, the western part on the south-western pillar.
 - 2.16a. The ornamental frieze of the northern under-dome arch, the eastern part on the north-eastern pillar.
 - 2.16b. The ornamental frieze of the northern under-dome arch, the western part on the north-western pillar.
 - 2.16c. The fragment of the fresco, covered by the mosaic ornamental frieze, on the north-western pillar.
 - 2.17a. The ornamental frieze of the western under-dome arch, the northern part on the north-western pillar.
 - 2.17b. The ornamental frieze of the western under-dome arch, the southern part of frieze on the south-western pillar.
 - 2.17c. The fragment of the fresco covered by the mosaic ornamental frieze on the north-western pillar.
 - 2.18. The southern under-dome arch, the medallions with the Sebaste Martyrs and the medallion with a cross.
 - 2.19. The northern under-dome arch, the medallions with the Sebaste Martyrs (preserved five medallions on the eastern slope) and the medallion with a cross.
 - 2.20. The western under-dome arch, the medallions with the Sebaste Martyrs (the fresco fragments preserved on the southern slope).
 - 2.21. The north-eastern pillar, the western lesene, the figure of Archangel Gabriel of the "Annunciation".
 - 2.22. The south-eastern pillar, the western lesene, the figure of the Virgin Mary of the "Annunciation".
 - 2.23. The north-eastern pillar, the southern pilaster, (the northern pilaster of the altar arch), the figure of the high priest Aaron.
 - 2.24. The north-western pillar, the southern pilaster, the fresco figure of an unknown martyr.
 - 2.25. The south-western pillar, the northern pilaster, the fresco figure of an unknown martyr.
 - 2.26. The altar apse, the figure of Virgin Oranta.
 - 2.27. The lunette over the apse conch, two fragments of the inscription with the poem from the Book of Psalms (45:6).
 - 2.28. The altar apse, "Eucharist".
 - 2.29. The altar apse, the northern wall, the rank of holy bishops.
 - 2.30. The altar apse, the southern wall, the rank of the holy bishops.
 - 2.31. The lunette over the apse conch, "Deësis" ("Threemorphon").
 - 2.32. The bema, the northern wall, a fragment of a mosaic with an ornament and the remnant of the plot composition.
 - 2.33. The bema, the north wall, a mosaic fragment with rests of a background area.
 - 2.34. The bema, the north wall, the fresco fragment with a figure of a saint.
 - 2.35. The bema, the north wall, the fresco fragment with an ornament.
3. The bema, the northern wall with fragments of mosaics in the upper part and frescos fragments in the lower part; the northern surface of the altar arch with the mosaic image of the high priest Aaron.
4. The north-eastern pillar, the figure of Archangel Gabriel of the "Annunciation"; alongside on the south pilaster of the pillar is ornamental frieze of the eastern under-dome arch.
5. The south-eastern pillar, the figure of the Virgin Mary of the "Annunciation", alongside on the north pilaster of the pillar is ornamental frieze of the eastern under-dome arch.
6. The northern under-dome arch, eastern slope, the medallion with Leontius, the Martyr of Sebaste.
7. The western under-dome arch, a fragment of a fresco with the remnants of two medallions with martyrs of Sebaste.
8. The resonator holes: in the northeastern pendentive (on the left); in the southeastern pendentive (on the right).
9. The resonator hole and images of two crosses in the northwest pendentive.
10. The south-western pillar, the ornamental frieze of the western under-dome arch, the southern part.

11. The north-western pillar, the ornamental frieze of the western under-dome arch, the northern part.
12. The south-eastern pillar, the ornamental frieze of the southern under-dome arch, the eastern part.
13. The south-western pillar, the ornamental frieze of the southern under-dome arch, the western part.
14. The north-eastern pillar, the ornamental frieze of the western under-dome arch, the northern part.
- The north-western pillar, the ornamental frieze of the northern under-dome arch, the western part.
16. The north-western pillar, the lateral facets of the eastern pilaster, the fragment of the fresco panel, partly covered by the mosaic ornamental frieze.
17. The north-western pillar, the lateral facets of the southern pilaster, the fragment of the fresco panel, partly covered by the mosaic ornamental frieze.
18. The northwestern pillar, the southern pilaster, the fresco panels on its frontal and lateral facets, the mosaic ornamental frieze on the lateral facet partly overlaps the fresco panel below.
19. The south-western under-dome pillar, the north pilaster, a fresco figure of an unknown martyr and a panel below it.
20. The under-dome ring, the medallion over the eastern arch with image of Christ the Priest. A light rectangle below the cornice is probe with the remnants of the fresco plaster.
21. Bema, the northern wall, the fragment of a mosaic with an underneath and a background, near with the mosaic ornament on the apse ledge.
22. The cartogram of the samplings of mortars of mosaics and frescoes plasters in the under-dome space in 2014 (after the sample number, the index "M" — a mosaic plaster, the index "F" — a fresco plaster, the index "M / F" - mosaic mortar, which overlaps the bottom layer of fresco mortar).
 - №1 M. The mosaic set on the three-layer plaster.
 - №2 M. The mosaic set on the three-layer plaster.
 - №3 M. The mosaic set on the three-layer plaster.
 - №4 M. Three layers of mosaic plaster with fresco framings of a mosaic image.
 - №5 M. The mosaic set on the three-layer plaster.
 - №6 M. The mosaic set on the two-layer plaster.
 - №7 M. Top layer of plaster with a mosaic set.
 - №8 M. Three layers of mosaic plaster with fresco framing strip of the mosaic ornamental frieze.
 - №9 M. Two layers of mosaic plaster with fresco framing strip of the mosaic ornamental frieze.
 - №10 M/F. A mosaic set is on two-layer plaster overlapping the preserved bottom layer of previous fresco plaster
 - №11 M/F. A mosaic set is on two-layer plaster which overlap the rests of previous fresco plaster
 - №12 M/F. The one surface layer mosaic plaster without a mosaic set, which covers the previous frescoes plaster.
 - №13 M/F. A mosaic set is on two layers of plaster which overlap the previous fresco plaster
 - №14 M/F. A mosaic set is on two layers of plaster which overlap the previous fresco plaster.
 - №15 F. The fragment of the previous fresco painting not covered with the mosaic plaster.
 - №16 F. A remnant of the previous fresco painting not covered with the mosaic plaster.
 - №17 F. A fresco painting outside the zone of mosaic decorations (beside the hole of the altar templone).
23. A fragment of ceramic (tseyanka), produced by burning of loess loam in mortar. A thin micro-section of plaster mortar in polarized light (10x objective zoom).
24. A fragment of burnt glass (slag) in mortar. A thin micro-section of plaster mortar in polarized light (10x objective zoom).
25. A fragment of unstable glass with a new formation (slag) in mortar. A thin micro-section of plaster mortar in polarized light (10x objective zoom).

Література / References:

1. Айналов Д., Редін Е. Киево-Софійський собор. Исследование древней мозаической и фресковой живописи. — СПб., 1889.
2. Болховітінів Євгеній. Вибрані праці з історії Києва. — К., 1995.
3. Закревський Н. Описание Киева. — М., 1868. — Т. 2.
4. Каргер М. К. Древний Киев: Очерки по истории материальной культуры древнерусского города. — Москва; Ленинград, 1961. — Т. 2.
5. Комеч А. И. Древнерусское зодчество конца X — начала XII в.: Византийское наследие и становление самостоятельной традиции. — М., 1987.
6. Крыжановский С. Киевские мозаики // Записки Императорского Русского археологического о-ва. — СПб., 1856. — Т. 8. — С. 235 — 270.
7. Лазарев В. Н. Новые данные о мозаиках и фресках Софии Киевской // Византийский временник. — 1956. — Т.10. — С.161 — 177. С. 161 — 165
8. Лазарев В. Н. Мозаики Софии Киевской. — М., 1960.
9. Лазарев В. Н. Фрески Софии Киевской // В.Н. Лазарев Византийское и древнерусское искусство. — М., 1978. — С. 65 — 115.
10. Левыцкая В. И. О некоторых вопросах набора мозаик Софии Киевской // Византийский временник. — М., 1959. — Т. 15. — С. 170 — 183.
11. Левыцкая В. И. Материалы исследований мозаик Софии Киевской // Византийский временник. — М., 1963. — Т. 23. — С. 105 — 157.
1. Aynalov D., Redyn E. Kyievo-Sofiyskyy sobor. Yssledovanye drevney mozaicheskoy y freskovoy zhivopisy. — SPb., 1889.
2. Bolkhovitinov Yevheniy. Vybrani pratsi z istoriyi Kyyyeva. — K., 1995.
3. Zakrevskyy N. Opysahnye Kyeva. — M., 1868. — T. 2.
4. Karher M. K. Drevnyy Kyev: Ocherky po ystoriy materiyal'noy kul'tury drevnerusskoho horoda. — Moskva; Lenynhrad, 1961. — T. 2.
5. Komech A. Y. Drevnerusskoe zodchestvo kontsa Kh — nachala KhII v.: Vyzantyysskoe nasledye y stanovlenye samostoyatel'noy tradytsyy. — M., 1987.
6. Kryzhanovskyy S. Kyevskyye mozaiky // Zapysky Ymperatorskoho Russkoho arkeolohycheskoho o-va. — SPb., 1856. — T. 8. — S. 235 — 270.
7. Lazarev V. N. Novyye dannyye o mozaikakh y freskakh Sofyy Kyevskoy // Vyzantyysskyy vremennyk. — 1956. — T.10. — S.161 — 177. S. 161 — 165
8. Lazarev V. N. Mozaiky Sofyy Kyevskoy. — M., 1960.
9. Lazarev V. N. Fresky Sofyy Kyevskoy // V.N. Lazarev Vyzantyysskoe y drevnerusskoe yskusstvo. — M., 1978. — S. 65 — 115.
10. Levytskaya V. Y. O nekotorykh voprosakh nabora mozaik Sofyy Kyevskoy // Vyzantyysskyy vremennyk. — M., 1959. — T. 15. — S. 170 — 183.
11. Levytskaya V. Y. Materyaly yssledovany mozaik Sofyy Kyevskoy // Vyzantyysskyy vremennyk. — M., 1963. — T. 23. — S. 105 — 157.

12. *Левецкая В. И.* О палитре Михайловских мозаик // В.Н. Лазарев Михайловские мозаики. — М., 1966. — С. 103 — 133.
13. *Лидов А. М.* Образы Христа в храмовой декорации и византийская христология после схизмы 1054 г. // Древнерусское искусство: Византия и Древняя Русь. К 100-летию Андрея Николаевича Грабара 1896 — 1999. — СПб., 1999. — С. 155–176.
14. *Логвин Г. Н.* Новые наблюдения в Софии Киевской // Культура средневековой Руси. — Ленинград, 1974. — С. 154 — 160.
15. *Логвин Г. Н.* К истории сооружения Софийского собора в Киеве // Памятники культуры. Новые открытия. Ежегодник. (1977). — М., 1977. — С. 169 — 186.
16. *Стріленко Ю. М.* Аналіз зразків фрескових та будівельних розчинів Софії Київської // Стародавній Київ. — К., 1975. — С. 195–201.
17. *Толстой И., Кондаков Н.* Русские древности в памятниках искусства. Христианские древности в памятниках Крыма, Кавказа, Киева. — СПб., 1891. — Вып. 4.
18. *Тоцька І. Ф.* Про час виникнення галерей Софії Київської // Стародавній Київ. — К., 1975. — С. 182 — 194.
19. *Тоцька І. Ф.* Исследование строительного производства Киевской Софии. Проблемы изучения древнерусского зодчества. — СПб., 1996. — С. 28–29.
12. *Levytskaya V. I.* O palytre Mykhaylovskyykh mozaik // V.N. Lazarev Mykhaylovskyye mozaiky. — M., 1966. — S. 103 — 133.
13. *Lydov A. M.* Obrazy Khrysta v khramovoy dekoratsyy u vyzantyyiskaya khrystolohyya posle skhizmy 1054 h. // Drevnerusskoe yskusstvo: Vyzantyya y Drevnyaya Rus'. K 100-letyyu Andreyu Nykolaevycha Hrabara 1896 — 1999. — SPb., 1999. — S. 155–176.
14. *Lohvyn H. N.* Novyye nablyudeniya v Sofyy Kyevskoy // Kul'tura srednevekovoy Rusy. — Lenynhrad, 1974. — S. 154 — 160.
15. *Lohvyn H. N.* K ystoryy sooruzhenyya Sofyyiskoho sobora v Kyeve // Pamyatnyky kul'tury. Novyye otkrytiya. Ezhehodnyk. (1977). — M., 1977. — S. 169 — 186.
16. *Strilenko Yu. M.* Analiz zrazkiv freskovykh ta budivel'nykh rozchyniv Sofiyi Kyuyivskoy // Starodavniy Kyuyiv. — K., 1975. — S. 195–201.
17. *Tolstoy I., Kondakov N.* Russkyye drevnasty v pamyatnykakh yskusstva. Khrystyanskye drevnasty v pamyatnykakh Kryma, Kavkaza, Kyeva. — SPb., 1891. — Vyp. 4.
18. *Tots'ka I. F.* Pro chas vynyknenniya halerey Sofiyi Kyuyivskoy // Starodavniy Kyuyiv. — K., 1975. — S. 182 — 194.
19. *Totskaya I. F.* Yssledovanye stroitel'nogo proyzvodstva Kyevskoy Sofyy. Problemy yzucheniya drevnerusskoho zodchestva. — SPb., 1996. — S. 28–29.

Корениук Юрій Олександрович, Гуцуляк Роман Борисович, Шевченко Наталія Олександрівна
Новий погляд на періодизацію створення архітектурного ансамблю Софійського собору
в Києві на основі останніх досліджень мозаїк і фресок підкупольного простору

Анотація. В статті наведені результати досліджень, які проводилися під час консервації мозаїк північної частини підкупольного простору Софії Київської в 2013–2014 рр. В процесі робіт з'ясувалося, що тинькові основи мозаїчних орнаментальних фризів на північно-західному підкупольному стовпі перекривають фрагменти фрескових розписів, які існували на ньому до появи мозаїк. У процесі зондування та відбору проб тинькових основ мозаїк під ними ще в кількох місцях підкупольного простору були виявлені залишки нижнього шару фрескового тиньку. Це дає підставу вважати, що мозаїка в підкупольному просторі Софії Київської не є первинною декорацією, як вважалося раніше, а замінила фрески, якими підкупольний простір був розписаний початково.

Ключові слова: Софія Київська, мозаїка, фреска, монументальний живопис, штукатурний розчин, наповнювач розчину.

Корениук Юрий Александрович, Гуцуляк Роман Борисович, Шевченко Наталья Александровна
Новый взгляд на периодизацию создания архитектурного ансамбля Софийского собора
в Киеве на основе последних исследований мозаик и фресок подкупольного пространства

Аннотация. Статья содержит результаты исследований, проводившихся при консервации мозаик северной части подкупольного пространства Софии Киевской в 2013–2014 гг. В процессе работ обнаружилось, что фрагменты мозаичных орнаментальных фризів на северо-западном столбе перекрывают фресковые росписи, существовавшие на нем до возникновения мозаик. В процессе зондирования и отбора проб штукатурных оснований мозаик под ними еще в нескольких местах подкупольного пространства были обнаружены остатки нижележащей фресковой штукатурки. Это дает основания считать, что мозаика в подкупольном пространстве Софии Киевской не является первоначальной декорацией, как считалось ранее, а заменила существовавшие ранее фресковые росписи.

Ключевые слова: София Киевская, мозаики, фрески, монументальная живопись, штукатурный раствор, наполнитель раствора.