

FLEXIBLE WAVELET-NEURO-FUZZY NEURON IN DYNAMIC DATA MINING TASKS

Ye. Bodyanskiy, I. Pliss, O. Vynokurova

Kharkiv National University of Radio Electronics, Control Systems Research Laboratory,
av. Lenina, 14, Kharkiv, 61166, Ukraine,
e-mail: {bodya, pliss, vinokurova}@kture.kharkov.ua

Запропоновано нову гнучку модифікацію нео-фаззи нейрону та алгоритм навчання усіх параметрів. Запропонований алгоритм навчання дає змогу налаштувати не тільки синаптичні ваги, але й параметри функції активації-приналежності та її форми, що дає змогу уникнути виникнення «дірок» у входному просторі. Запропонований алгоритм навчання має як фільтруючі, так і властивості слідування, таким чином гнучкий нео-фаззи нейрон може використовуватися для вирішення задач прогнозування, фільтрації та згладжування нестационарних стохастичних і хаотичних послідовностей. Перевагами запропонованого підходу є простота обчислення у порівнянні з відомими алгоритмами навчання гібридних вейвлет-нейро-фаззи систем обчислювального інтелекту.

Ключові слова: гнучкий нео-фаззи нейрон, гнучкі функції активації-приналежності, алгоритм навчання, прогнозування, ідентифікація

Предлагается новая гибкая модификация нео-фаззи нейрона и алгоритм обучения всех его параметров. Предложенный алгоритм обучения позволяет настраивать не только синаптические веса, но и параметры функций активации-принадлежности и ее формы, что позволяет избежать возникновения «дырок» во входном пространстве. Предложенный алгоритм обучения обладает как фильтрующими, так и следящими свойствами, таким образом гибкий нео-фаззи нейрон может использоваться для решения задач прогнозирования, фильтрации и сглаживания нестационарных и хаотических последовательностей. Преимуществом предложенного подхода являются вычислительная простота в сравнении с известными алгоритмами обучения гибридных вейвлет-нейро-фаззи систем вычислительного интеллекта.

Ключевые слова: гибкий нео-фаззи нейрон, гибкая функция активации-принадлежности, алгоритм обучения, прогнозирование, идентификация.

A new flexible modification of neo-fuzzy neuron (FNFN) and adaptive learning algorithms for the tuning of its all parameters are proposed in the paper. The algorithms are interesting in that they provide on-line tuning of not only the synaptic weights and membership functions parameters, but also forms of these functions, that provide improving approximation properties and allow to avoid the occurrence of "gaps" in space of inputs. The proposed algorithms have both the tracking and filtering properties, so the FNFN can be effectively used for prediction, filtering and smoothing of non-stationary stochastic and chaotic sequences. A special feature of the proposed approach is its computational simplicity in comparison with known learning procedures for hybrid wavelet-neuro-fuzzy systems of computational intelligence.

Keywords: flexible neo-fuzzy neuron, flexible activation-membership function, learning algorithm, forecasting, identification

Introduction

Artificial neural networks (ANN), fuzzy inference systems (FIS) and wavelet systems (WS) have been widely used in recent years to solve a wide range of problems such as Dynamic Data Mining [1], [2] and processing of essentially non-stationary signals of different nature under a priori and current uncertainty. Hybrid wavelet-neuro-fuzzy systems [3], [4], [5], [6] emerged as a synergism of these three directions in computational intelligence. The wavelet-neuro-fuzzy systems possess the learning capabilities similar to those of neural networks, provide the interpretability and transparency of results, inherent to the fuzzy approach, and similarly effective systems for non-stationary signal processing with local features.

The main disadvantages of wavelet-neuro-fuzzy systems especially when using in on-line mode are related to the slow convergence of the conventional gradient - based learning procedures and computational complexity of second-order procedures when using in sequential adaptive vari-

ants. Furthermore significant problems may arise in the processing of non-stationary signals, since the second order procedures, for example, exponentially weighted recurrent least squares method can be numerically instable.

Neo-fuzzy neuron and its architecture

To overcome these difficulties, a hybrid neuro-fuzzy system called "neo-fuzzy neuron" (Fig. 1) was proposed in [7, 8, 9]. As it can be see the architecture of neo-fuzzy neuron is guide close to the conventional n -inputs artificial neuron, however, instead of usual synaptic weights w_{ji} it contains so called nonlinear synapses $NS_i, i = 1, 2, \dots, n$.

When an input vector signal $x(k) = (x_1(k), x_2(k), \dots, x_n(k))^T$ (here $k = 1, 2, \dots$ is current discrete time) is fed to the input of the neo-fuzzy neuron, its output is defined by both the membership functions $\mu_{ji}(x_i(k))$ (its authors have

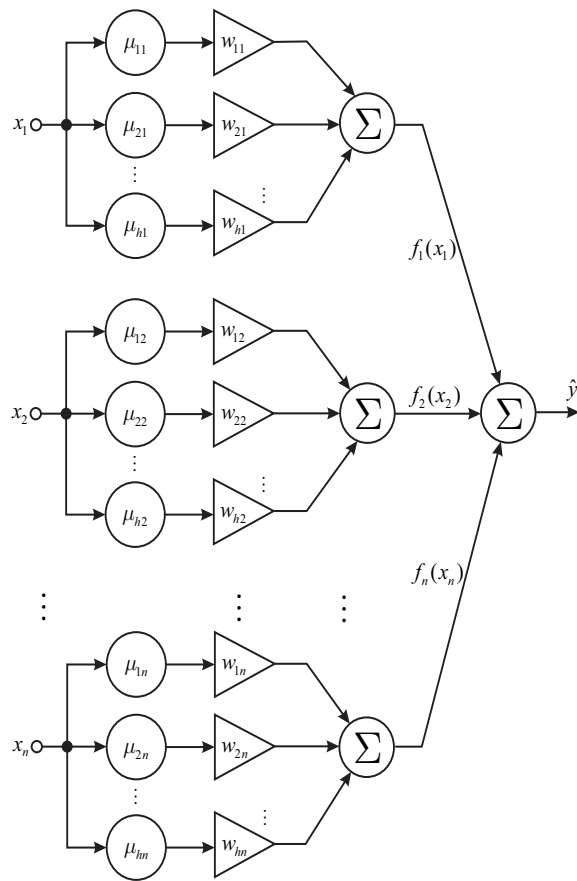

Figure 1 – Neo-fuzzy neuron

used usual triangular functions) and the tunable synaptic weights $w_{ji}(k)$:

$$\hat{y}(k) = \sum_{i=1}^n f(x_i(k)) = \sum_{i=1}^n \sum_{j=1}^n w_{ji}(k-1) \mu_{ji}(x_i(k)). \quad (1)$$

Using the learning criterion in the form of standard quadratic error function

$$E(k) = \frac{1}{2} (y(k) - \hat{y}(k))^2 = \frac{1}{2} e^2(k) \quad (2)$$

minimized via the usual gradient descent procedure, it's easy to write weights update algorithm in the form

$$w_{ji}(k+1) = w_{ji}(k) = \eta e(k+1) \mu_{ji}(x_i(k+1)), \quad (3)$$

where $y(k)$ is the target value of the output (reference signal), η is the learning rate parameter which determines the rate of the convergence and as a rule is chosen empirically.

The authors of neo-fuzzy neuron note [9], among its most important advantages, the rate of learning, high approximation properties, computational simplicity, the possibility of finding the global minimum of the learning criterion in real time.

At the same time efficiency of this system is reduced when processing nonstationary signals disturbed by noises of unknown nature.

For the increasing learning rate in [10] adaptive optimal learning algorithm was proposed in the form

$$w_{ji}(k+1) = w_{ji}(k) + \frac{e(k+1) \mu(x(k+1))}{\|\mu(x(k+1))\|^2}, \quad (4)$$

which is a variety of the known optimal Kaczmarz-Widrow-Hoff procedure. Here

$$w(k) = (w_{11}(k), w_{21}(k), \dots, w_{h1}(k), w_{12}(k), \dots,$$

$$w_{h2}(k), \dots, w_{ji}(k), \dots, w_{1n}(k), \dots, w_{hn}(k))^T,$$

$$\mu(k) = (\mu_{11}(x_1(k)), \mu_{21}(x_1(k)), \dots, \mu_{h1}(x_1(k)), \mu_{12}(x_2(k)), \dots, \mu_{h2}(x_2(k)), \dots, \mu_{ji}(x_i(k)), \dots, \mu_{1n}(x_n(k)), \dots, \mu_{hn}(x_n(k)))^T - (hn \times 1) \text{-vectors; } i = 1, \dots, n; j = 1, \dots, h.$$

For the providing both tracking (in non-stationary) and filtering (when stochastic disturbances corrupt the processed signal) for the neo-fuzzy neuron modified adaptive procedure was used

$$\begin{cases} w(k+1) = w(k) + r^{-1}(k+1)e(k+1)\mu(x(k+1)), \\ r(k+1) = \beta r(k+1) + \|\mu(x(k+1))\|, \\ 0 \leq \beta \leq 1, \end{cases} \quad (5)$$

(here β is forgetting factor), based on Goodwin-Ramadge-Caines stochastic approximation procedure [11] for adaptive identification tasks.

Further modification of neo-fuzzy neuron was connected to the improvement its approximation properties. Thus, in [10] instead of the triangular membership functions the second degree polynomials were proposed to use, and in [12] fourth-degree polynomials. In [13, 14] cubic and B-splines functions were proposed to use, and in [4, 5, 15, 16] – different types of odd wavelets. Here the additional learning algorithm for wavelet functions centers, widths and shape parameters were proposed.

Flexible neo-fuzzy neuron with tunable form of membership functions

Let's introduce an activation-membership function that is described by the expression

$$\mu_{ji}(x_i(k)) = \left(1 - \alpha_{ji}(k) \left| \tau_{ji}(k) \right|^{s_{ji}(k)}\right) \times \exp\left(-\frac{\left| \tau_{ji}(k) \right|^{s_{ji}(k)}}{s_{ji}(k)}\right), \quad (6)$$

where $\tau_{ji}(k) = (x_i(k) - c_{ji}(k)) \sigma_{ji}^{-1}(k)$; $c_{ji}(k)$ is center of activation-membership function; $\sigma_{ji}(k)$ is width of activation-membership function; $\alpha_{ji}(k)$ is shape parameter of activation-membership function; $s_{ji}(k)$ is flexible parameter of activation-membership function.

It is obvious that when $\alpha = 0, s = 2, \sigma = 1$ $\mu_{ji}(x_i(k))$ is Gaussian function (Fig. 2a), when

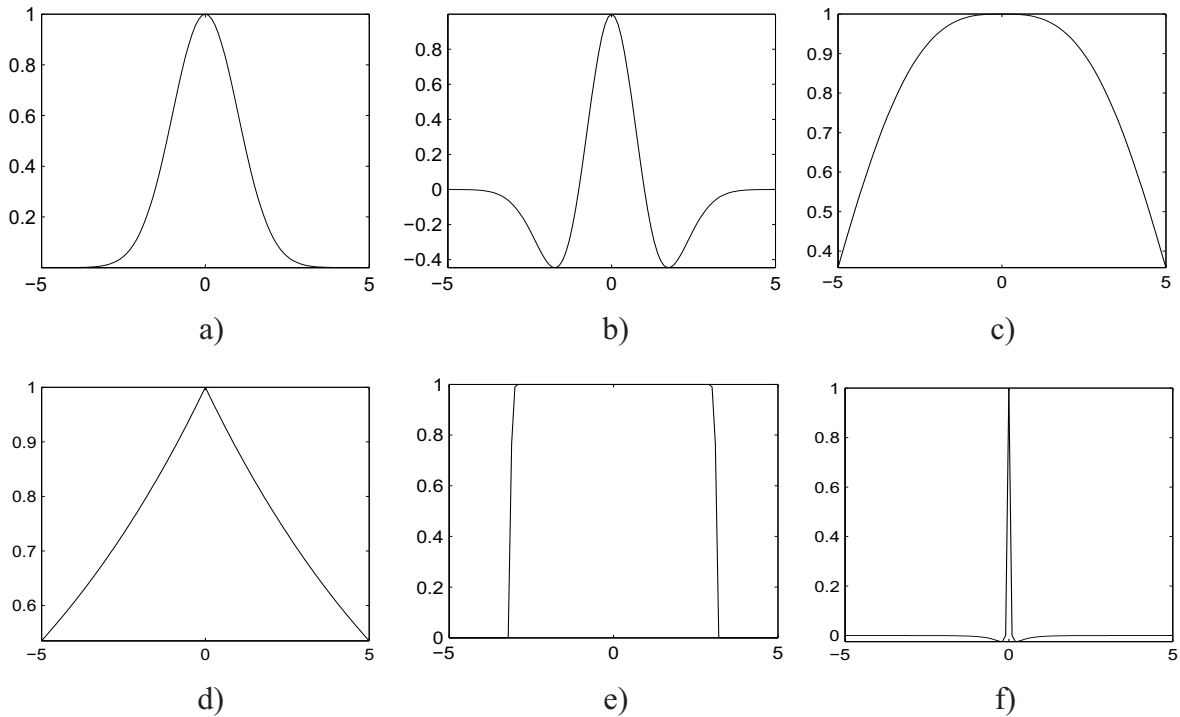

Figure 2 – Flexible activation-membership function for different parameters value

$\alpha = 1, s = 2, \sigma = 1$ – wavelet Mexican Hat (Fig. 2b),
 $\alpha = 0, s = 100, \sigma = 3$ – trapezoidal-like function (Fig. 2d),
 $\alpha = 0, s = 1, \sigma = 8$ triangular-like function (Fig. 2e) and etc (Fig. 2c, Fig. 2f).

Fig. 2 shows the forms of such function for different parameters value.

As is obvious, this is or bell-shape functions or wavelet-like ones. The centers and widths of such functions are determined by parameters c and σ , and shape of functions is determined by parameters α and s .

Minimizing of learning criterion (2) on the all-parameters leads to the learning algorithm

$$\begin{cases} w_i(k+1) = w_i(k) + \eta^w(k+1)e(k+1)J_i^w(k+1), \\ c_i(k+1) = c_i(k) + \eta^c(k+1)e(k+1)J_i^c(k+1), \\ \sigma_i^{-1}(k+1) = \sigma_i^{-1}(k) + \eta^\sigma(k+1)e(k+1)J_i^\sigma(k+1), \\ \alpha_i(k+1) = \alpha_i(k) + \eta^\alpha(k+1)e(k+1)J_i^\alpha(k+1), \\ s_i(k+1) = s_i(k) + \eta^s(k+1)e(k+1)J_i^s(k+1). \end{cases} \quad (7)$$

where

$$\begin{aligned} J_i^w(k) &= (J_{li}^w(k), \dots, J_{hi}^w(k)), \\ J_i^c(k) &= (J_{li}^c(k), \dots, J_{hi}^c(k)), \\ J_i^\sigma(k) &= (J_{li}^\sigma(k), \dots, J_{hi}^\sigma(k)), \\ J_i^\alpha(k) &= (J_{li}^\alpha(k), \dots, J_{hi}^\alpha(k)), \\ J_i^s(k) &= (J_{li}^s(k), \dots, J_{hi}^s(k)), \end{aligned}$$

$$\begin{cases} J_{ji}^w(k) = \varphi_{ji}(x_i(k)), \\ J_{ji}^c(k) = w_{ji}(k) \sigma_{ji}^{-1}(k) |\tau_{ji}^{-1}(k)|^{s_{ji}(k)-1} \text{sign}(\tau_{ji}(k)) \times \\ \quad \times (\alpha_{ji}(k) s_{ji}(k) + 1 - \alpha_{ji}(k) |\tau_{ji}(k)|^{s_{ji}(k)}) \times \\ \quad \times \exp\left(-\frac{|\tau_{ji}(k)|^{s_{ji}(k)}}{s_{ji}(k)}\right), \\ J_{ji}^\sigma(k) = -w_{ji}(k) (x_i(k) - c_{ji}(k)) |\tau_{ji}^{-1}(k)|^{s_{ji}(k)-1} \times \\ \quad \times \text{sign}(\tau_{ji}(k)) (\alpha_{ji}(k) s_{ji}(k) + 1 - \alpha_{ji}(k) |\tau_{ji}(k)|^{s_{ji}(k)}) \times \\ \quad \times \exp\left(-\frac{|\tau_{ji}(k)|^{s_{ji}(k)}}{s_{ji}(k)}\right), \\ J_{ji}^\alpha(k) = w_{ji}(k) |\tau_{ji}(k)|^{s_{ji}(k)} \exp\left(-\frac{|\tau_{ji}(k)|^{s_{ji}(k)}}{s_{ji}(k)}\right), \\ J_{ji}^s(k) = w_{ji}(k) ((-\alpha_{ji}(k) |\tau_{ji}(k)|^{s_{ji}(k)} \ln|\tau_{ji}(k)|) + \\ \quad + (1 - \alpha_{ji}(k) |\tau_{ji}(k)|^{s_{ji}(k)}) (|\tau_{ji}(k)|^{s_{ji}(k)} s_{ji}^{-2}(k) + \\ \quad + |\tau_{ji}(k)|^{s_{ji}(k)} \ln|\tau_{ji}(k)| s_{ji}^{-1}(k))) \exp\left(-\frac{|\tau_{ji}(k)|^{s_{ji}(k)}}{s_{ji}(k)}\right). \end{cases}$$

When optimizing procedure (7) on its rate of convergence and introducing tracking and filtering properties we get final expression:

$$\left\{ \begin{aligned} w_i(k+1) &= w_i(k) + \frac{e(k+1)J_i^w(k+1)}{r_i^w(k+1)}, \\ r_i^w(k+1) &= r_i^w(k) + \beta r_i^w(k) + \|J_i^w(k+1)\|, \\ c_i(k+1) &= c_i(k) + \frac{e(k+1)J_i^c(k+1)}{r_i^c(k+1)}, \\ r_i^c(k+1) &= r_i^c(k) + \beta r_i^c(k) + \|J_i^c(k+1)\|, \\ \sigma_i^{-1}(k+1) &= \sigma_i^{-1}(k) + \frac{e(k+1)J_i^\sigma(k+1)}{r_i^\sigma(k+1)}, \\ r_i^\sigma(k+1) &= r_i^\sigma(k) + \beta r_i^\sigma(k) + \|J_i^\sigma(k+1)\|, \\ \alpha_i(k+1) &= \alpha_i(k) + \frac{e(k+1)J_i^\alpha(k+1)}{r_i^\alpha(k+1)}, \\ r_i^\alpha(k+1) &= r_i^\alpha(k) + \beta r_i^\alpha(k) + \|J_i^\alpha(k+1)\|, \\ s_i(k+1) &= s_i(k) + \frac{e(k+1)J_i^s(k+1)}{r_i^s(k+1)}, \\ r_i^s(k+1) &= r_i^s(k) + \beta r_i^s(k) + \|J_i^s(k+1)\|, \\ 0 &\leq \beta \leq 1. \end{aligned} \right. \quad (9)$$

Experimental results

The efficiency of the proposed flexible neo-fuzzy neuron and its learning procedures was tested in the problem of real-time forecasting of chaotic and stochastic non-stationary signals.

Efficiency of flexible neo-fuzzy neuron was examined based on solving forecasting problem of real ecological time series. This time sequence describes monthly pressure above the sea level from 1882 to 1998 (Darwin sea level pressure). This time series is a key indicator of climate change, as well as important in the study of the effect of the El Nino or Southern Oscillation index.

Fig. 3 shows the results of time series forecasting. The two curves, representing the actual (dot line) and forecasting (solid line) values, are almost indistinguishable.

Inputs number of flexible neo-fuzzy neuron were taken as $n = 6$, that for input vector in the form $x(k-5), x(k-4), x(k-3), x(k-2), x(k-1), x(k)$ for the prediction value $\hat{x}(k+1)$. Flexible neo-fuzzy neuron was training using proposed learning algorithm during 900 iterations (900 points of training sample for $k = 1 \dots 900$). Initial parameters values of learning algorithm were taken $r^w, r^c, r^\sigma, r^\alpha, r^s$, and shape and flexible parameter value of flexible membership-activation function was taken as $\alpha = 0.5, s = 3$. After 900 iterations the training process was stopped, and the next 500 points for $k = 901 \dots 1400$ we have used as the testing data set to compute forecast. Initial values of synaptic weights were taken equal to 0. As the quality criterion of forecasting root mean square error (MSE) was used.

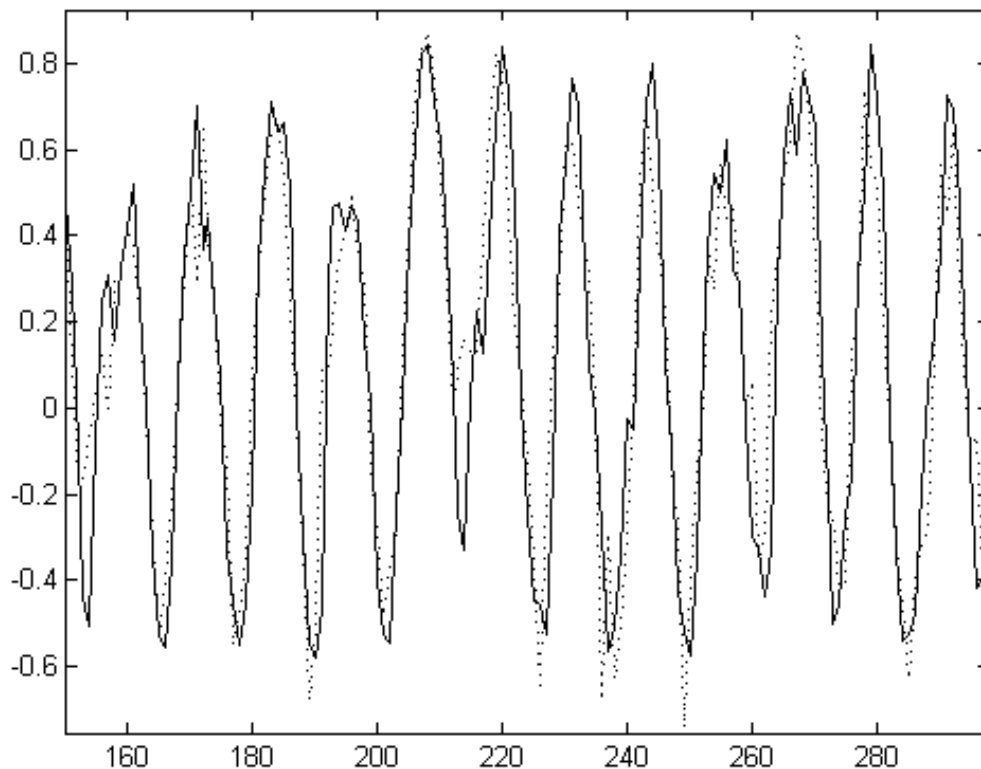

Figure 3 – Results of time series forecasting

Table 1 – Comparative analysis of forecasting time series results

Neural network / Learning algorithm	MSE
Flexible neo-fuzzy neuron /Proposed learning algorithm (9) (all parameters)	0.0023
Flexible neo-fuzzy neuron / Proposed learning algorithm (9) (only synaptic weight)	0.0054
Neo-fuzzy neuron / Gradient learning algorithm	0.0134

Table 1 shows comparative analysis of forecasting time series based on different approaches.

Conclusion

Flexible neo-fuzzy neuron with membership functions of variable tunable forms and adaptive learning algorithms with tracking and filtering properties are proposed. The learning algorithms are simple in implementation and provide high quality of signal processing in on-line mode. Tuning of membership functions form improves the accuracy of modelling of nonlinear non-stationary processes. This was shown in the experiments of different time series forecasting. The proposed approach may be effectively used in many Dynamic Data Mining tasks.

References

1 V. Raghavan, A. Hafez, Dynamic Data Mining, J. of the American Society for Information Science, (2000), P.220-229.

2 E. Lughofer, Evolving Fuzzy Systems: Methodologies, Advanced Concepts and Applications, Springer, 2011.

3 Abiyev R.H., Kaynak O.: Fuzzy wavelet neural networks for identification and control of dynamic plants - A novel structure and a comparative study. IEEE Trans. on Industrial Electronics, 55(8) 3133–3140 (2008)

4 Ye. Bodyanskiy, I. Pliss, O. Vynokurova, Adaptive wavelet-neuro-fuzzy network in the forecasting and emulation tasks, Int. J. on Information Theory and Applications, 15 (1), (2008), 47-55.

5 Ye. Bodyanskiy, I. Pliss, O. Vynokurova, Hybrid wavelet-neuro-fuzzy system using adaptive W-neurons. Wissenschaftliche Berichte, FH Zittau/Goerlitz, 106(N.24542490), (2008), 301–308.

6 Ye. Bodyanskiy, I. Pliss, O. Vynokurova, Hybrid GMDH-neural network of computational intelligence, in: Proc. 3rd International Workshop on Inductive Modelling, Poland, Krynica, (2009), 100-107.

7 T. Miki, T. Yamakawa, Analog implementation of neo-fuzzy neuron and its onboard learning, In N.E. Mastorakis, editor, Computational Intelligence and Application. WSES Press, (1999), 144-149.

8 T. Yamakawa, T. Miki, E. Uchino, H. Kusanagi, A neo fuzzy neuron and its applications to system identification and prediction of the system behavior, in: Proc. 2-nd Int. Conf. on Fuzzy Logic and Neural Networks - "IIZUKA-92", Iizuka, Japan, (1992), 477-483.

9 E. Uchino, T. Yamakawa, Soft computing bases signal prediction, restoration, and filtering, in Da Ruan, editor, Intelligent Hybrid Systems: Fuzzy Logic, Neural Networks, and Genetic Algorithms, Boston, Kluwer Academic Publishers, (1997), 331-349.

10 Ye. Bodyanskiy, I. Kokshenev, V. Kolodyazhniy, An adaptive learning algorithm for a neo fuzzy neuron, in Proc. 3-nd Int. Conf. of European Union Society for Fuzzy Logic and Technology (EUSFLAT'03), Zittau, Germany, (2003), 375-379.

11 G.C. Goodwin, P.J. Ramadge, P.E. Caines, A globally convergent adaptive predictor, Automatica, 17(1), (1981), 135-140.

12 Ye.V. Gorshkov, V.V. Kolodyazhniy, I.P. Pliss, Adaptive learning algorithm for a neo-fuzzy neuron and neuro-fuzzy network based on a polynomial membership functions, Bionica Intellecta, 61(1), (2004), 78-81.

13 Ye. Bodyanskiy, Ye. Viktorov, The cascade neo-fuzzy architecture using cubic spline activation functions, Int. J. Information Theories and Application, 16(3), (2009), 245-259.

14 V. Kolodyazhniy, Ye. Bodyanskiy, Cascaded multiresolution spline-based fuzzy neural network, Eds. P. Angelov, D. Filev, N.Kasabov, in Proc. Int. Symp. on Evolving Intelligent Systems, Leicester, UK, (2010), 26-29.

15 Ye. Bodyanskiy, N. Lamonova, I. Pliss, O. Vynokurova, An adaptive learning algorithm for a wavelet neural network, Expert Systems, 22(5), (2005), 235-240.

16 Ye. Bodyanskiy, O. Vynokurova, Hybrid adaptive wavelet-neuro-fuzzy system for chaotic time series identification. Information Science, 220, (2013), 170-179.

*Стаття надійшла до редакційної колегії
11.11.13
Рекомендована до друку
професором Семенцовим Г.Н.
(ІФНТУНГ, м. Івано-Франківськ)*