

ром реализованы возможности исследования взаимодействия режущей кромки с поверхностью резания, в том числе и обрабатываемой поверхностью, при условии как их совпадения, так и не совпадения. Впервые усовершенствован процесс чистового червячного зубофрезерования эвольвентных поверхностей, при котором поверхность резания не совпадает с обусловленной эвольвентной поверхностью, а расположена к ней под углом.

**Практическая значимость.** Повышен порядок уровня астатизма одномассовой колебательной консервативной системы за счет изменения харак-

тера (геометрии) взаимодействия режущей кромки и обрабатываемой поверхности, что адекватно введению в систему интегрирующего звена. Реализована схема червячного зубофрезерования на базе контурного взаимодействия режущей кромки и обрабатываемой поверхности.

**Ключевые слова:** динамическая модель, режущая кромка, астатизм системы, чистовое зубофрезерование

*Рекомендовано до публікації докт. техн. наук В. І. Носуленком. Дата надходження рукопису 21.04.16.*

UDC 622.625.28

V. P. Franchuk, Dr. Sc. (Tech.), Prof.,  
K. A. Ziborov, Cand. Sc. (Tech.), Assoc. Prof.,  
V. V. Krivda, Cand. Sc. (Tech.), Assoc. Prof.,  
S. O. Fedoriachenko, Cand. Sc. (Tech.), Assoc. Prof.

State Higher Educational Institution "National Mining University", Dnipro, Ukraine, e-mail: franchuk@nmu.org.ua

## ON WHEEL ROLLING ALONG THE RAIL REGIME WITH LONGITUDINAL LOAD

В.П. Франчук, д-р техн. наук, проф.,  
К.А. Зіборов, канд. техн. наук, доц.,  
В.В. Кривда, канд. техн. наук, доц.,  
С.О. Федоряченко, канд. техн. наук, доц.

Державний вищий навчальний заклад „Національний гірничий університет“, м. Дніпро, Україна, e-mail: franchuk@nmu.org.ua

## ПРО РЕЖИМ КОЧЕННЯ КОЛЕСА ПО РЕЙКАХ ЗА НАЯВНОСТІ ПОЗДОВЖНЬОГО НАВАНТАЖЕННЯ

**Purpose.** Determination of the functional correlation between power (tangential reaction) and kinematic (relative slip) parameters during nonstationary rectilinear motion of the rail wheel along the rail.

**Methodology.** An analytical model of the interaction between the wheel and rail on an elementary contact area taking into account the presence of normal and shearing load (thrust or braking mode) is developed. Using the analytical model, a qualitative relationship that reflects the features of the friction contact of a wheel-rail pair for various operating conditions is obtained considering the nature of the interaction of the contacting pair, which significantly differs. The mathematical description of the process is based on experimental studies of the dependence of the tractive force on the speed of relative motion (incomplete slippage - the so-called creep mode, failure of adhesion and total sliding, which leads to decrease in traction force) of D. K. Minov and A. A. Renhevyeh.

**Findings.** On the basis of theoretical studies of the parameters of vehicle motion along the rail track, a mathematical model of the tangential reaction realization by wheel in the case of nonstationary rectilinear motion is formulated. The functional relationship between the power and kinematic parameters is established, which allows predicting the operational properties and solving the problems of the dynamics of rail transport with a higher degree of accuracy.

**Originality.** Taking into account inelastic resistance of contacting bodies, analytical dependences are obtained to determine the current value of the force at the contact area upon the availability of longitudinal load. The interaction conditions under which the deformation can occur both within the elasticity of the materials of the contacting bodies and the violation of the surfaces contact are considered. Approximating dependences of tractive effort on the relative speed of wheel and rail movement are proposed for locomotives.

**Practical value.** Knowledge of the processes occurring in the contact area while transferring the torque from the wheel of the locomotive to the rail will facilitate finding the correct solution to the problem of interaction between the wheel-rail system of mining rail transport in complex mining and geological operational conditions. It helps to increase the efficiency of torque transmission at the quasi-stationary mode of vehicle movement.

**Keywords:** longitudinal load, contact spot, stress, creep, rail transport

**Introduction.** As an executive device of the traditional tractive unit of mine locomotive a wheel is used, acting as a friction pair by interacting with the rail. The

parameters of the wheel pair must meet the requirements of optimality both from the position of performing the functions of the support element – to perceive and transfer the weight of the locomotive to the support surface and the traction drive element – to create a trac-

tion force that overcomes the motion resistance. In this lies the contradictions imposing restrictions on the parameters and design solutions of a number of elements of the undercarriage, the drive and the locomotive as a whole [1].

On the one hand, the wheel, as a supporting element, should track the trajectory of the track that, due to its imperfections, is never rectilinear in the vertical surface, which contributes to the dynamic components of the loads in all links of the drive. The fact that the wheel pair acts as a guiding element of the locomotive also facilitates the dynamic loading of the drive [2], and therefore directly interacts with the rail and in the transverse direction. On the other hand, the traction force is realized by friction in the contact area between the wheel and the rail, therefore it is limited by the frictional properties of the contacting surfaces and by the force of pressing them against each other [3].

The existing experience of using locomotives suggests that certain reserves for increasing the use of tractive forces are embodied in the realization of opportunities that depend on the conditions for contacting bandage-rail and the physical-chemical properties of the contacting surfaces of the shroud and rail, as well as not the idealized but actual processes in the contact area. It should be noted, however, that the tasks involved in investigating the conditions for contact formation, taking into account the properties and shapes of these surfaces, are very complex.

For the mine conditions, while determining the traction and braking characteristics [3], it is also necessary to take into account the difference of wheel diameters in a wheel set, the wear of the rolling surfaces of the rails [4] and the wheel bands, the widening of the track, the poor condition of the joints and switch points [5], the local deflection of the rails and the inclination of rails, the mining technology and properties of enclosing rocks [6].

In connection with the reasons denoted earlier, there is still no unified theory of the cohesion of locomotive wheels with rails describing the interaction of the contacting materials of the shroud and rail in the whole variety of processes.

**Objective of the article** is to determine the functional connection of the force (tangential reaction) and the kinematic (relative slip) parameters for the non-stationary rectilinear motion of the wheel.

**Presentation of the main research and explanation of scientific results.** Knowledge of the physics of the processes occurring in the contact zone during the transmission of the torque from the locomotive wheel to the rail is of the utmost importance for seeking a correct solution of the problem of the interaction of the wheel-rail system.

As is known, the motion of a body at a certain instant of time is determined by the vector of linear velocity of an arbitrarily chosen reference point of the body and the vector of its circumferential velocity in the rotational motion with respect to some axis passing through this point. The influence of the factors listed above leads to the fact that the probability of coincidence of the same points of contact  $O_1$  and  $O_2$  (Fig. 1) on the surface of the

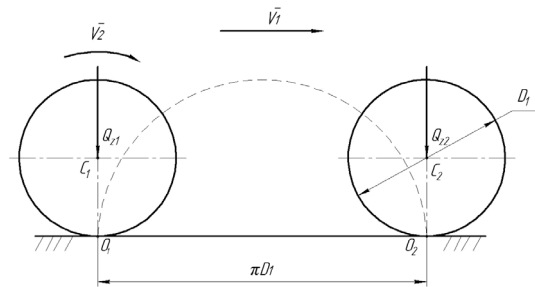

Fig. 1. Scheme of locomotive wheel movement on the rail for nonstationary rectilinear motion

wheel and track is random for the wheel with each revolution.

With each revolution of the wheel, elastic and plastic deformations occur under the action of external forces and internal energy of the material on the support surface of the wheel on the rail (Fig. 2), so that the elements of the wheel-rail friction pair come into contact over a finite-size site. The actual conditions of the interaction of the wheel and rail lead to the fact that at each moment of time, not only the different forces of pressing the wheel act on the rail ( $Q_{z1}, Q_{z2}$ ), but also the shape and size of the support area change.

The resultant force transmitted from the surface of the rail to the wheel of the wheel pair is decomposed into a normal  $Q_z$  reaction acting along the common normal, and tangential  $Q_{xy}$  acting in the tangential plane and experiencing resistance from the frictional forces [7]. The magnitude of the force should be less or in the limiting state equal to the force of limiting friction, i.e.

$$Q_{xy} \leq \mu_0 \cdot Q_z,$$

where  $\mu_0$  is the coefficient of the boundary friction.

The vector of linear speed of movement of a wheel pair  $V_1$  (Fig. 1) consists of the rolling speed of the wheel  $V_2$  and the speed of its sliding  $\vec{V}_{\text{rel}} = \vec{V}_2 - \vec{V}_1$ , which is characterized by the combined action of deformations and sliding of contact points.

Let us consider the interaction of the wheel and rail on an elementary contact section of length  $2a$  and width

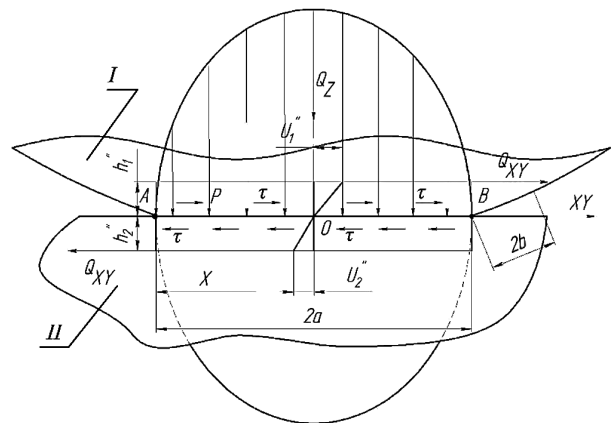

Fig. 2. Calculation scheme of the interaction of a wheel-rail pair with longitudinal load (thrust or braking mode)

2b (Fig. 2), with normal  $Q_z$  and shifting load  $Q_{xy}$  (thrust or braking mode). The nominal height of the shear force application to one body is  $h_1''$ , to another it is  $h_2''$ .

For each of the contacting bodies (Fig. 2), the strain value is determined by the expressions

$$U_1'' = h_1' \frac{\tau}{E_1}; \quad U_2'' = -h_2' \frac{\tau}{E_2},$$

where  $E_1$  and  $E_2$  are elasticity modulus of the interacting materials;  $h_1'$  and  $h_2'$  are conditional “height of deformed layer” – dimensional coefficient, which characterizes the value and character of the roughness distribution.

With an increase in the limiting value  $\tau$  and the constant time of its increase up to this limit, the rate of deformation will increase.

If the deformation is

$$U_{12} = U_1'' - U_2''$$

(and hence the speed of this deformation) exceeds a certain value, the so-called friction of the friction occurs and an increase in the relative strain rate leads to a decrease in the cohesion coefficient.

The physics of this process is well described by D. K. Minov and V. V. Protsiv [1], they also give data on the dependence of traction on the speed of relative motion (incomplete slippage – the so-called creep mode, disruption of adhesion and full sliding, which leads to a reduction in traction force).

As it was noted earlier, during the interaction of the wheel with the rail under the action of the normal load  $Q_z$  (Fig. 3), a deformation occurs and a contact area is formed in the form of an ellipse with dimensions  $2a$  and  $2b$ .

As the wheel moves, the contact area moves as well. At the same time, the approach of bodies and deformation of the compression of the layers of the wheel and rail occur in the  $AO$  section. On the segment  $OB$ , the deformed layers are regenerated. Under the influence of the force  $Q_{xy}$ , the shear of the boundary layers, contacting bodies is deformed. Moreover, the deformation can occur both within the elasticity of the materials of the contacting bodies and with the disruption of contact between the surfaces. However, even with purely elastic

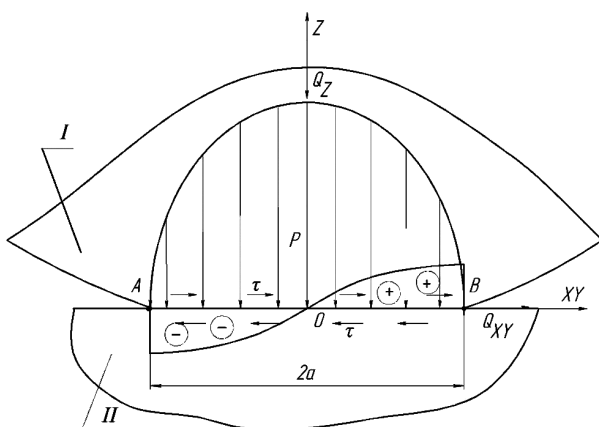

Fig. 3. Calculation scheme for the interaction of bodies at the contact site, taking into account inelastic resistances

shear deformation, the relative motion of the contacting layers occurs, the so-called creep phenomenon. This “creep” is associated with minimal wear on the surfaces. Naturally, if there is no shear load  $Q_{XY}$ , there will be no relative slippage of the contacting bodies. The behavior of the system will depend on the type and condition of the contacting surfaces, on the normal load  $QZ$  (normal pressure at the contact site  $p$ ), on the contact time (body velocity  $V$ ), and on a number of other factors [6].

The analysis of the proposed analytical dependencies and the results of experimental studies for the coefficient of adhesion as a function of the velocity of relative surface slip  $v_{12}$  shows [6] that for the case under consideration the function of the dependence of shear loads on the relative velocity has the form

$$\tau = \mu_0 p \cdot \frac{\alpha' v_{12}}{\delta' v_{12} + \beta v_{12} + \lambda_1 V},$$

where  $\mu_0$  is the coefficient taking into account the materials properties (excluding the environmental influence);  $\alpha'$ ,  $\beta$ ,  $\delta'$  are the coefficients of the surface state of the interacting bodies, the interaction duration, load etc.;  $\lambda_1$  is the coefficient, covering materials characteristics, value and the manner of roughness characterization, velocity parameters of load application.

In general, if considered in more detail, the coefficients  $\alpha'$  and  $\lambda_1$  will depend on the parameters in one way or another connected with the speed of movement  $V$ : the actual area of contact, the temperature in the contact zone (its influence on the modulus of elasticity of the contacting bodies materials), and so on.

Each of the coefficients carries its own load, although it is possible that several coefficients are simultaneously influenced by one external parameter. Denoting also

$$\kappa_{12} = \frac{v_{12}}{V},$$

the equation determining the traction capacity of bodies with a moving contact point is obtained in the form

$$\tau = \mu_0 \alpha p \frac{\kappa_{12}}{\delta \kappa_{12}^2 V + \beta \kappa_{12} + \lambda}.$$

Assuming

$$\chi = \frac{\tau}{\mu_0 \alpha p}.$$

We obtain the value of the coefficient of the bodies interaction with a moving contact point

$$\chi = \frac{\kappa_{12}}{\delta \kappa_{12}^2 V + \beta \kappa_{12} + \lambda}. \quad (1)$$

We obtain the value of the coefficient of interaction between the bodies and a moving point of contact (Fig. 4).

As follows from the graph, the maximum value of the tractive force will be at  $\kappa_{12}$ , corresponding to the position of  $A$  (for this mode of motion and the state of the contacting surfaces).

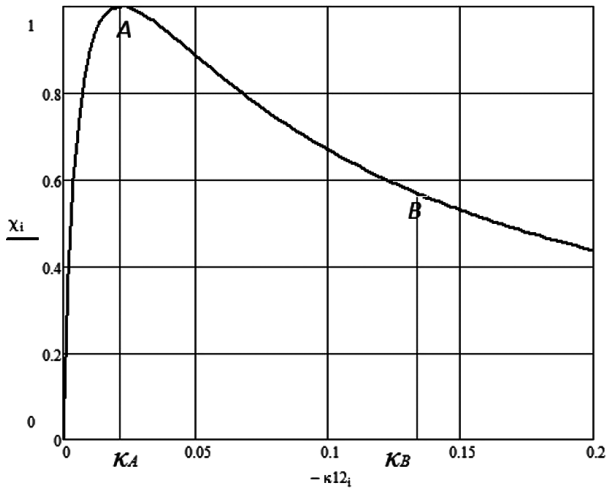

Fig. 4. Dependence of the tractive force of the interaction bodies with a moving contact point on the relative contact speed:

*A* is the characteristic point corresponding to the maximum value of the tractive force; *B* is the point of the characteristic, corresponding to the friction of the grip (skidding)

This corresponds to the regime of incomplete slip, which corresponds to the displacement of the contacting surfaces within the elastic deformations of the boundary layers. With further increase in the relative ve-

locity, outside the limits of point *A*, a disruption of the grip occurs and the slippage regime sets in. In this case, uncontrolled sliding of surfaces (unstable regime) occurs, associated with increased wear.

Fig. 5, *a* shows the experimentally obtained graph of the dependence of tractive effort on the relative speed of movement of the wheel and rail at the speed of the rail vehicle  $V = 36$  km/h (10 m/s) [6].

Here, too, in Fig. 5, *b*, the curve obtained from the data of Fig. 5, *a*. As we see, qualitatively the pictures are identical, i.e. qualitatively, the dependence (1) describes quite well the process of interaction of a wheel with a rail.

Using this approach, it is possible to obtain a qualitative dependence that reflects the particular frictional contact between the wheel-rail pair for the mine operating conditions (Fig. 6, *a*) [5], where the interaction conditions of the contacting pair is significantly different from the main (at a speed of the rail vehicle  $V = 14$  km/h ( $\sim 4$  m/s)).

When the wheel moves along a rail that has a convex head, the contact spot will look like an ellipse with semi-axes *a* and *b* (Fig. 2). The Hertz-Belyaev formulas make it possible to calculate the dimensions of the contact spot for the case of elastic interaction of surfaces of revolution.

The maximum stresses arising in this case will be equal to

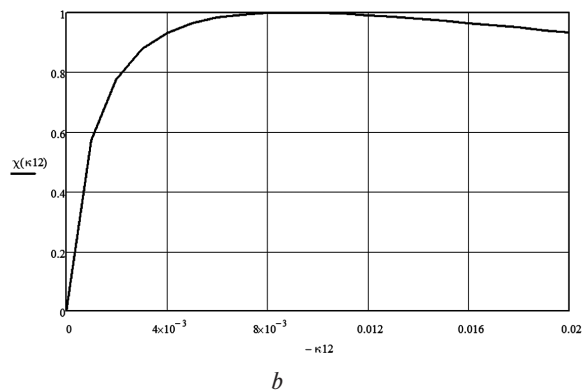
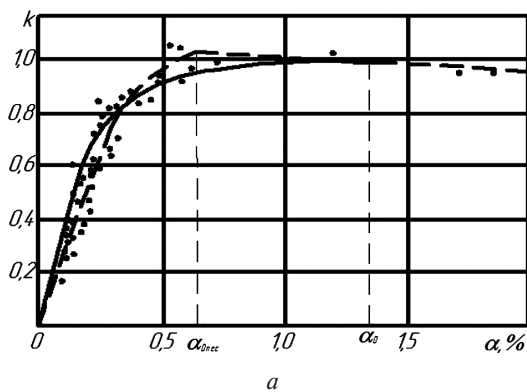

Fig. 5. Experimental (*a*) (by D. K. Minov) and approximating (*b*) dependencies for rail vehicles

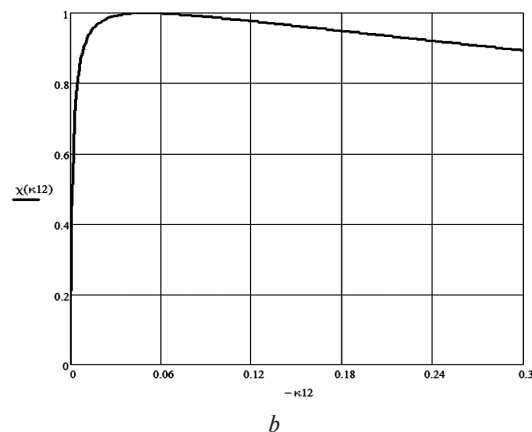
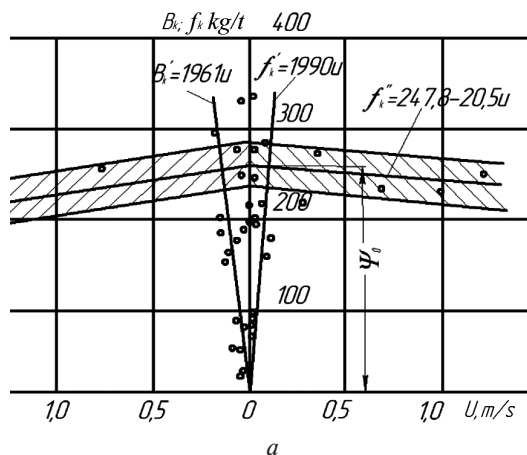

Fig. 6. Experimental (*a*) (by A. A. Renhevych) and approximating (*b*) dependencies for mine locomotives



$$p_0 = \frac{1,5Q}{\pi ab}$$

The current value of the stress on the contact spot will be

$$p = p_0 \sqrt{1 - \xi_a^2} \sqrt{1 - \xi_b^2},$$

where  $\xi_a, \xi_b$  stand for the relation  $\xi_a = \frac{x}{a}$ ;  $\xi_b = \frac{y}{b}$ .

$$(-a \leq x \leq a, -b \leq y \leq b); \xi_a^2 + \xi_b^2 \leq 1.$$

This is in the ideal case. In fact, when the movement of a rail wheel vehicle (for example, a mine locomotive) due to elastic imperfections of the material of contacting bodies, the picture will change somewhat [6]. Inelastic resistance in the interaction is adopted in the form proposed by E. V. Sorokin, in the form of a complex elastic modulus  $E = E_0(1 + i\gamma)$ , where  $\gamma$  is the cyclic energy absorption coefficient, is related to the energy absorption coefficient and the damping decrement by the relation

$$\gamma = \frac{\psi}{2\pi} = \frac{\delta z}{\pi},$$

where, in its turn,

$$\psi = \frac{\Delta W}{W},$$

where  $\psi$  is the absorption energy coefficient;  $W$  is the total energy of the oscillation cycle;  $\Delta W$  is dissipated energy;  $\delta z$  is attenuation decrement.

Taking the motion along the  $x$ -axis as harmonic and bringing the complex form to the harmonic form, one can obtain the current value of the force on the contact area. With this, the dependence of shear stresses will have the form

$$\tau = p_0 \sqrt{1 - \xi_a^2} \sqrt{1 - \xi_b^2} H[1 - (\xi_a^2 + \xi_b^2)] \frac{\mu_0 \alpha \kappa_{12}}{\delta \kappa_{12}^2 V + \beta \kappa_{12} + \lambda}$$

or

$$\tau = p_0 \sin \varphi_\alpha \sin \varphi_\beta H[1 - (\sin^2 \varphi_\alpha + \sin^2 \varphi_\beta)] \times \frac{\mu_0 \alpha \kappa_{12}}{\delta \kappa_{12}^2 V + \beta \kappa_{12} + \lambda};$$

$$\varphi_\alpha \in 0 \dots \pi; \quad \varphi_\beta \in 0 \dots \pi.$$

Determining tractive effort when the wheel and rail contact the entire contact area as

$$Q_{xy} = \int_{-a}^a \int_{-b}^b \tau dx dy = p_0 ab \frac{\mu_0 \alpha \kappa_{12}}{\delta \kappa_{12}^2 V + \beta \kappa_{12} + \lambda} \times \int_{-1}^1 \sqrt{1 - \xi_a^2} d\xi_a H[1 - (\xi_a^2 + \xi_b^2)] \int_{-1}^1 \sqrt{1 - \xi_b^2} d\xi_b,$$

where  $H[1 - (\xi_a^2 + \xi_b^2)]$  is Heaviside function;

$$H(x) = \begin{cases} 1 & \text{while } x \geq 0 \\ 0 & \text{while } x < 0 \end{cases}.$$

After integrating and substituting (6), we obtain

$$Q_{xy} = \frac{1,5\pi}{4} Q_z \frac{\mu_0 \alpha \kappa_{12}}{\delta \kappa_{12}^2 V + \beta \kappa_{12} + \lambda}.$$

An error in 18 % can be assumed, taking into account the error in the coefficient  $\alpha$

$$Q_{xy} = \mu_0 \alpha Q_z \frac{\kappa_{12}}{\delta \kappa_{12}^2 V + \beta \kappa_{12} + \lambda}. \quad (2)$$

Thus, the tractive effort depends on the normal load at the contact point  $QZ$ , the speed of the relative motion  $\kappa_{12}$  of the contacting bodies, the absolute velocity of displacement  $V$ , the elastoplastic properties and the construction of the surface of the contacting bodies determined by the coefficients  $\beta, \delta, \lambda$ .

The coefficient  $\mu_0$  depends on the material of the contacting bodies and is defined as the classical coefficient of friction of rest. As for the coefficient  $\alpha'$ , it determines the state of the surface of the contacting bodies (the presence of lubricant, pollutants, etc.), as well as the temperature at the contact point. This also includes corrections that the real coefficient of friction has, in contrast to the coefficient of friction of rest, the corrections introduced into the experiment by the actual regime of motion of the contacting bodies.

**Conclusions.** In the paper, based on of theoretical research of the parameters of vehicle motion along the railroad track, a mathematical model of realization of the tangential reaction by the wheel and rail in the case of nonstationary rectilinear motion is formulated that establishes the functional connection of the power and kinematic parameters and allows predicting a greater degree of accuracy of operational properties and solve the problems of the dynamics of rail transport. The obtained dependences (1, 2) show a significant change in the traction properties of a rail vehicle in the region of characteristics outside the creep. Taking into account inelastic resistances, represented as a complex modulus of elasticity, makes it possible to evaluate the degree of influence of the physical and mechanical properties of the contacting surfaces on realization of the maximum traction effort.

### References.

1. Patsera, S., Protsiv, V. and Kosmin, V., 2015. Feasible Ways to Improve the Durability of the Pumps' Parts Operating with Hydroabrasive Mixtures. *Mechanics, Materials Science & Engineering*, [e-journal] 1, pp. 133–138. <http://dx.doi.org/10.13140/RG.2.1.4039.5286>.
2. Matsyuk I. and Shliakhov, E., 2015. The research of plane link complexstructure mechanisms by vector algebra methods, *Eastern European Journal of Enterprise Technologies*, pp. 34–38.
3. Krivda, V. V., Bas, K. M. and Plakhotnik, V. V., 2013. Influence of the road profile and dump truck parameters on the exploitation indexes. *Naukovyi Visnyk Natsionalnoho Hirnychoho Universytetu*, 4, pp. 59–64.
4. Samusya, V., Oksen, Y. and Radiuk, M., 2013. Heat pumps for mine water heat recovery. In: *Mining of Mineral Deposits*, CRC Press, [e-journal] pp. 153–157, <http://dx.doi.org/10.1201/b16354-27>.

5. Deriuhin O. and Cheberichko, S., 2015. Substation of truck selection in terms of minimizing psychophysiological stress on a driver, *Eastern European Journal of Enterprise Technologies*, 3(3), pp. 15–22.
6. Semrad, K., Cernan, J. and Draganova, K., 2016. Rolling Contact Fatigue Life Evaluation Using Weibull Distribution. *Mechanics, Materials Science & Engineering*, [e-journal] 3. pp. 28–34. <http://dx.doi.org/10.13140/RG.2.1.3338.9849>.
7. Kyrychenko, Y. O., Samusya, V. I., Kyrychenko, V. Y. and Romanyukov, A. V., 2013. Experimental investigation of aero-hydroelastic instability parameters of the deepwater hydrohoist pipeline. *Middle East Journal of Scientific Research*, 18(4), pp. 530–534.

**Мета.** Визначення функціонального зв'язку силового (дотична реакція) та кінематичного (відносно ковзання) параметрів при нестационарному прямолінійному русі колеса рейкового транспорту.

**Методика.** Розроблена аналітична модель взаємодії колеса й рейки на елементарній ділянці контакту за наявності нормального й зсувного навантаження (режим тяги або гальмування). Отримана якісна залежність, що відображає особливості фрикційного контакту пари „колесо – рейка“ для різних умов експлуатації, де характер взаємодії контактуючої пари істотно відрізняється. Математичний опис процесу заснований на експериментальних дослідженнях залежності тягового зусилля від швидкості відносного руху (неповне прослизання – так званий режим кріпа, зрив зчеплення й повне ковзання, що несе за собою зниження сили тяги) Д. К. Мінова, А. А. Ренгевича.

**Результати.** На основі теоретичних досліджень параметрів руху транспортного засобу по рейковому шляху сформульована математична модель реалізації колесом рейкового транспортного засобу дотичної реакції при нестационарному прямолінійному русі. Встановлено функціональний зв'язок силового й кінематичного параметрів, що дозволить із більшим ступенем точності прогнозувати експлуатаційні властивості та вирішувати завдання динаміки рейкового транспорту.

**Наукова новизна.** З урахуванням непружних опорів при взаємодії контактуючих тіл отримані аналітичні залежності для визначення поточного значення зусилля на ділянці контакту за наявності поздовжнього навантаження. Розглянуті умови взаємодії, за яких деформація може відбуватися як у межах пружності матеріалів контактуючих тіл, так і з порушенням контакту поверхонь. Запропонована апроксимуюча залежність тягового зусилля від відносної швидкості руху колеса й рейки як для магістральних, так і для шахтних локомотивів.

**Практична значимість.** Знання процесів, що відбуваються в зоні контакту при передачі крутного моменту від колеса локомотива до рейки, дозволить знайти правильне рішення проблеми взаємодії системи „колесо – рейка“ шахтного рейкового транспорту при складних гірничо-геологічних умовах експлуатації та підвищить ефективність переда-

чі крутного моменту при квазістационарному режимі руху транспортного засобу.

**Ключові слова:** *поздовжнє навантаження, зона контакту, напруження, кріп, рейковий транспорт*

**Цель.** Определение функциональной связи силового (касательная реакция) и кинематического (относительное скольжение) параметров при нестационарном прямолинейном движении колеса рельсового транспорта.

**Методика.** Разработана аналитическая модель взаимодействия колеса и рельса на элементарном участке контакта при наличии нормальной и сдвигающей нагрузки (режим тяги или торможения). Получена качественная зависимость, отражающая особенности фрикционного контакта пары „колесо – рельс“ для различных условий эксплуатации, где характер взаимодействия контактирующей пары существенно отличается. Математическое описание процесса основано на экспериментальных исследованиях зависимости тягового усилия от скорости относительного движения (неполное проскальзывание – так называемый режим кріпа, срыв сцепления и полное скольжение, влекущее за собой снижение силы тяги) Д. К. Минова, А. А. Ренгевича.

**Результаты.** На основе теоретических исследований параметров движения транспортного средства по рельсовому пути сформулирована математическая модель реализации колесом рельсового транспортного средства касательной реакции при нестационарном прямолинейном движении. Установлена функциональная связь силового и кинематического параметров, что позволит с большей степенью точности прогнозировать эксплуатационные свойства и решать задачи динамики рельсового транспорта.

**Научная новизна.** С учетом неупругих сопротивлений при взаимодействии контактирующих тел получены аналитические зависимости для определения текущего значения усилия на площадке контакта при наличии продольной нагрузки. Рассмотрены условия взаимодействия, при которых деформация может происходить как в пределах упругости материалов контактирующих тел, так и с нарушением контакта поверхностей. Предложены аппроксимирующие зависимости тягового усилия от относительной скорости движения колеса и рельса как для магистральных, так и для шахтных локомотивов.

**Практическая значимость.** Знание процессов, происходящих в зоне контакта при передаче вращающего момента от колеса локомотива к рельсу, позволит найти правильное решения проблемы взаимодействия системы „колесо – рельс“ шахтного рельсового транспорта при сложных горно-геологических условиях эксплуатации и повысит эффективность передачи крутящего момента при квазістационарном режиме движения транспортного средства.

**Ключевые слова:** *продольная нагрузка, пятно контакта, напряжения, кріп, рельсовый транспорт*

*Рекомендовано до публікації докт. техн. наук О. М. Коптовцем. Дата надходження рукопису 13.04.16.*