

**Le Xuan Thanh,**  
orcid.org/0000-0001-5052-4484,  
**Ho Viet Bun,**  
orcid.org/0000-0003-2123-9179

HaNoi University of Mining and Geology, HaNoi, Socialist Republic of Vietnam, e-mail: [lexuanthanh@humg.edu.vn](mailto:lexuanthanh@humg.edu.vn)

## ANALYZING AND IDENTIFYING THE LIMITS OF 660V GRID PARAMETERS TO ENSURE ELECTRICAL SAFETY IN UNDERGROUND COAL MINES

**Purpose.** To study the relation between leakage current and time, then to identify some limits of grid parameters to ensure electrical safety as well as explosion safety corresponding to all operating modes of leakage relay in Vietnam underground mines.

**Methodology.** In underground coal mines of Vietnam, 660 V grids are characterized by ungrounded neutral point electric system. They require very serious and strict operation conditions including electrical safety and explosion safety. In daily operation, the earth leakage currents (earth fault currents) must be lower than the allowance limit. However, when utilizing many new power electronic devices such as variable speed drive (VSD), the quantity of connected equipment changes due to the change in capacitance current. After measuring the grid parameters, leakage currents are computed in terms of 3 compensating levels of earth fault relays. The resulting values of currents are used to build up limit curves.

**Findings.** Curves of the graphs present the relation between the leakage current and the length of transmission cables associated with various connecting equipment. The curves may be used to operate the electric system safely and effectively.

**Originality.** The proposed equations and simulation in Matlab may be applied to all underground mining grids with different input parameters.

**Practical value.** Operating curves of the graphs are used to identify the most suitable grids parameters which could ensure electrical safety (keeping the leakage current within the allowance limits). It could help operators or technicians optimize the structure of grid and ensure its safety.

**Keywords:** 660 V grid, ungrounded neutral point, electrical safety, protection relay, coal mines

**Introduction.** In Vietnam underground mines, to meet the demand for increasing productivity, besides of increasing the nominal voltage of all underground mines from 380 to 660 V [1], the numbers of apparatus installed in 660 V have also been rapidly developed. The amount of connected electric equipment on the main 6 kV/660 V transformer has been increased by about 10 to 15 % to supply longer mining area. The length of underground cable-feeders has also got a rise of nearly 20 % [1, 2]. Greater numbers of connected apparatuses and longer length of underground feeders make the grid's structure and parameters change significantly. Going along with this change, the number of connection points on 660V grids has also risen causing the decrease in network insulation resistance. This change also brings the threat of electrical unsafe to electricians who normally operate with equipment.

To protect operators working in underground mines, most electric networks include a leakage protection relay installed in the main transformer substation [3, 4]. This relay (popularly called YAKИ) will operate whenever a leakage current occurs in the grid; its signal will be transmitted to the switching protective device (low voltage circuit breaker) located at the beginning of 660 V out coming feeders.

Some prior research studies point out that: there are many parameters affected on the rms of earthing current [5, 6], but the most impacted ones are: the length of cables, numbers of motors/equipment connected to the grid [7]. Those parameters are involved in rms of the capacitive component of earthing current (CCEC). In order to reduce the risk of earthing current, it is necessary to lower CCEC. One of useful and popular methods is inductive compensation. In Vietnam, the compensation is implemented in YAKИ. To operate effectively, all leakage protection relays typed YAKИ contain a coil which is used to compensate the capacitance element of leakage current [8, 9]. By connecting the compensation coil with three compensating levels, relays are considered to be the most effective protection devices on 660 V as well as 1140 V underground mining grids [10]. A typical connection diagram of a 660 V electric power system supplying energy with earth leakage relay for an underground mine area is shown in Fig. 1, the

connection of relay with the AФВ feeder circuit breaker and leakage relay is presented in Fig. 2.

Earth leakage relays in Fig. 2 are designed to continuously monitor the condition of insulation resistance in mining circuits. The relay operates in conjunction with an AФВ feeder air circuit breaker box and will open 660 V circuits in the following instances:

- when a mine worker comes in contact with a live part, and the current which could flow through his body would be able to reach a value dangerous for human life;
- when a mine worker comes in contact with a machine enclosure or frame which has accidentally acquired potential when the protective earthing is defective;
- when in any of the circuit phases, damage or failure of the insulation results in a fault to earth.

These relays receive supply from a selenium rectifier SR connected to one of the secondary winding coils ( $S_0-S_5$ ) of a transformer-choke T-Ch. When the insulation of the circuit is good, the current through the relay  $R$  will be insignificant and unable to operate it, the relay contacts  $R_1$  and  $R_2$  therefore remain open. The instant the total insulation resistance of the circuit (i.e. the resistance of all three phases relative to earth) drops to a value of 3500 ohms or less, a direct current sufficient for the relay to operate will flow.

The path of this current then becomes: minus terminal of the rectifier SR, relay winding  $R$ , ohmmeters, choke winding coils ( $Ch_4-Ch_0$ ) transformer-choke T-Ch, defective phase, earth at the fault, the earthing point of the earth-leakage relay, plus terminal of the rectifier SR. As the relay operates, it closes its  $R_1$  contact in the circuit of the trip (opening) coil TC of the circuit breaker to energize the coil and disconnect the faulty circuit. The relay simultaneously closes its  $R_2$  contact. It connects the relay winding directly to the plus terminal of the rectifier by shunting it to earth round the fault in the circuit. Burning of the relay contacts, and erratic operation of the relay are thus avoided when an intermittent or arcing fault occurs.

The function of the transformer-choke T-Ch is to interconnect the auxiliary d.c. circuit with the three-phase main or power circuit. An ohmmeter is incorporated to indicate the total insulation resistance of the circuit relative to earth. The push button PB provides the means for regularly checking the relay (when the PB is pressed, it faults one of the phases to

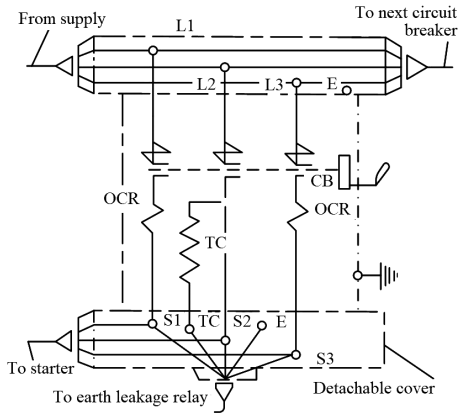

Fig. 1. A typical connection diagram of 660 V cable to earth leakage relay in underground mines

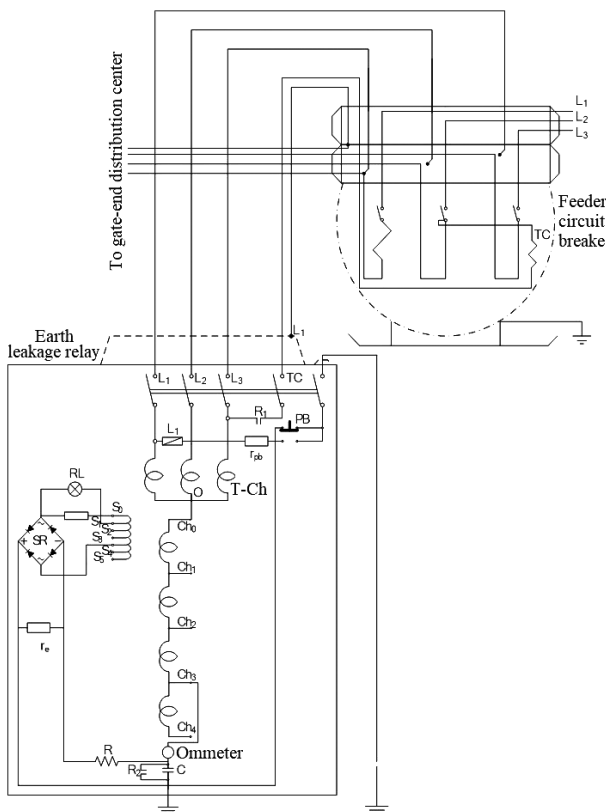

Fig. 2. The connection of earth leakage relay

earth through a resistor  $r_{PB}$ ). The earth leakage relay must be installed in the transformer substation and control the main feeder circuit breaker. Its enclosure must be reliably earthed and the auxiliary earthing point must not be closer than 5 meters from the local earthing point LE.

Whenever the circuit is opened automatically, it is essential to locate the fault. For this, all the manual and magnetic starters at the distribution centre must be de-energized and the feeder circuit breaker re-closed. If the latter trips open again, the fault is evidently in the armoured cable somewhere within the section from the feeder circuit breaker to the distribution centre.

However, if the circuit breaker remains closed, it is necessary to switch on the starters one after another, to determine which of the outgoing circuits causes the circuit breaker to be tripped open. The circuit breaker will also be tripped if, for example, there is a leakage path of 9000 to 10 000 ohms resistance in each of three outgoing flexible cables or motors. Since

these leakage paths will be connected in parallel, the total insulation resistance, when the three above cables or motors are connected to the supply, drops to from 3000 to 3300 ohms and causes the earth leakage relay to operate. In such cases, by permission of the mine electrical engineer, the protection may be slightly de-sensitized by lowering the d.c. voltage, accomplished by changing the rectifier supply lead connection terminal  $S_4$  to  $S_3$  or even  $S_1$ .

According to the Vietnamese National safety regulations [11, 12] all the metal frame of motors and electric equipment are connected to two earthing system, one is an individual earthing rod, the other is the centralized earthing system located at a transformer substation. The illustration of the systems is shown in Fig. 3.

By the Vietnam National standard [6, 13], the earthing system must meet the following requirements:

- the earthing value measured at any rod of the earthing system must be lower than 2;
- the value of the general earthing system measured at the transformer substation must be lower than 0.5 W;
- all individual earthing rods must be connected strongly to the essential earthing system by the 4<sup>th</sup> core of low voltage cables.

By supplying 660 V AC energy in such systems, whenever there is an earthing current, it will circulate through the earthing rod to the operation rod of relay for creating the switching-cut-out signal. The connection diagram of compensation coil in relay is shown in Fig. 4.

In Fig. 4, the coil contains 3 compensating levels corresponding to 3 changing taps. They are 0 mH (no compensa-

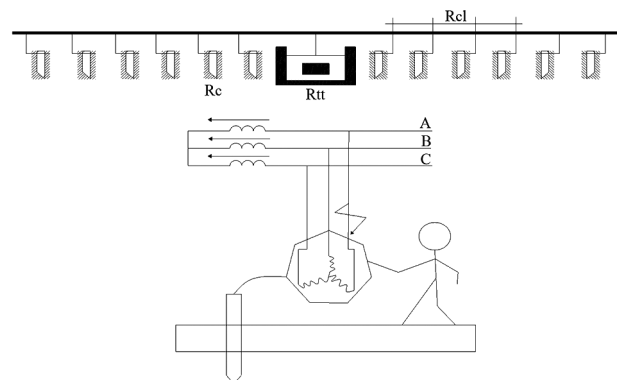

Fig. 3. Earthing system in Vietnam Underground mines

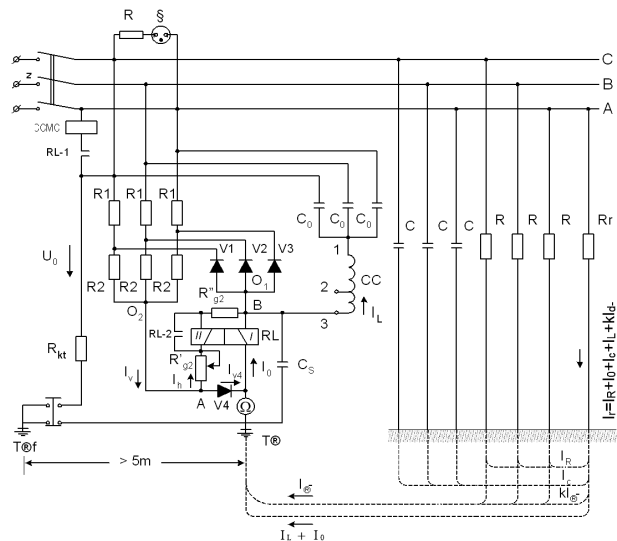

Fig. 4. Structure diagram of leakage relay protection relay YAKH with circulation of earthing current

tion), 10 mH and 18 mH (partly compensating). Obviously, when the taps are adjusted among “1 to 3” the grid’s capacitive value will be reduced. It causes the change in the leakage current’s value. Despite the fact that all grids are equipped with such sensitive leakage relays, there are still accidents of electric shock caused by the leakage current which is over the allowance limit (10 mA with AC) [9, 10]. Therefore, the managers/ chief operators of mines must limit factors which significantly increase the rms of the earthing current.

The paper examines the relations of above-mentioned parameters with value of earthing currents under alternative compensating level of YAKI to figure out safety operation limits.

**Computing the earthing current corresponding to 3 levels of compensation.** Generally, mine workers are affected by either touching to electric sources or stepping into potential effect area. Fig. 5 presents 2 common industry practices and equivalent resistance diagram. Because the body of a worker exposed to an electrical shock forms a shunt branch in an electrical circuit, the resistance of this branch should be identified to compute the corresponding body current. The hand and foot contact resistances are considered to be negligible. However, the resistance of the soil directly underneath the foot is usually significant.

The body itself has a total measured resistance of about 2300 Ω hand to hand or 1100 Ω hand to foot. In the interest of simplicity and conservatism, IEEE Std 80-1986 recommends the use of 1000 ohms as a reasonable approximation for body resistance ( $R_{ng}$ ) in both models. “Although in each of the cases discussed, body resistance shunts a part of the ground resistance, its actual effect on voltage and current distribution in the overall system is negligible. This becomes obvious when the normal magnitude of the ground fault current (as much as several thousand amperes) is compared to the desired body current (usually no more than several hundred milliamperes)” [14].

For analysing the electrical safety, it is necessary to identify the current running through the human being when a man has touched electric conducting parts of grids. Single line diagram is presented in Fig. 6. In the figure, the value of the body’s resistance is replaced by  $Y_{ng}$  which is inverted value of  $R_{ng}$ . Phase insulation resistance and capacitance are presented by  $g'_B, g'_C$  and  $3C$  correspondingly. Phase *A* is assumed to be the faulted phase in the grid.

The magnitude of current is calculated by equation [10, 15]

$$I_n = U_f g_n \frac{\sqrt{\left(3g + \frac{r_0}{r_0^2 + \omega^2 L^2}\right)^2 + \left(3\omega C - \frac{\omega L}{r_0^2 + \omega^2 L^2}\right)^2}}{\sqrt{\left(3g + g_n + \frac{r_0}{r_0^2 + \omega^2 L^2}\right)^2 + \left(3\omega C - \frac{\omega L}{r_0^2 + \omega^2 L^2}\right)^2}}, \quad (1)$$

where  $g_n$  is the body’s admittance,  $g_n = 1/R_{ng}$ ;  $C$  is compensated capacitance;  $L$  is inductance of compensation coil, the coil is mankind connected to neutral point of the grid.

When the capacitance element of the grid is partly compensated, this value of current is calculated by equation (2).

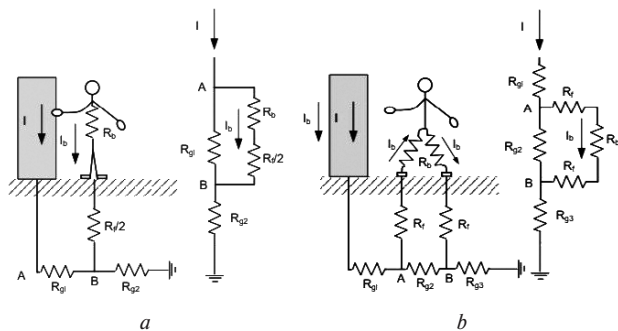

Fig. 5. Touch potential (a) and step potential (b) when a person is affected by electricity

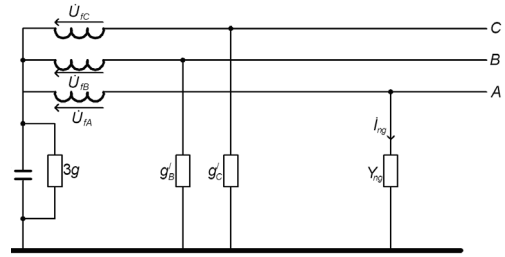

Fig. 6. Single line diagram of replaced circuit to compute earth current running through the human body

When the capacitance element of the grid is fully compensated, the faulted current is obtained by equation (3)

$$I_n = \frac{U_f}{R_n \sqrt{1 + \frac{R_{cd}(6R_n + R_{cd})}{9R_n^2(1 + \omega^2 C_{cd}^2 R_{cd}^2)}}}; \quad (2)$$

$$I_n = \frac{3U_f}{3R_n + R}. \quad (3)$$

In equations (1, 2) and (3) the current running through the human being’s body depends strongly on 2 factors [7, 16]:

-  $C_{cd}$  – capacitance elements of the grid (which is proportional to the length of feeders and the numbers of apparatus connected to grid;

-  $R_{cd}$  – insulation resistance of the grid.

The following part of the paper will analyse the impact of these quantities on value of  $I_n$ , then deduct to the relation the grid’s parameters to limit  $I_n$  lower than the allowance value.

**Results and discussion. Identifying the input values for simulation.** As analysed above, to determined correctly the value of faulted current as well as current running through the person’s body, it is necessary to identify the grid’s capacitance and insulation resistance. Then, those values will be utilized as inputs for simulation to obtain the outputs which present the relations of fault current  $I_f$  versus both the length of grid  $L$  and the number of connected motors  $N$ . To measure  $R$  and  $C$  of some grids in MongDuong underground coal mines the 3 volt-meter methods [10, 17] were used; the results (with operation of VSD) are shown in Table 1.

Similarly, other  $R_{cd}$  and  $C_{cd}$  of underground coal mines will be measured to input in the simulation.

**Simulation results.** To identify and form the curves for analysing the relation of leakage current versus the grid’s parameters, Matlab programming is utilized. Fig. 7 expresses the

Table 1

Measurements of  $R_{cd}$  and  $C_{cd}$  in MongDuong underground coal mine (Vietnam)

No.	Name of mining area	$R_{cd}$ kΩ/phase	$C_{cd}$ μF/phase
1	Area KT1	5.67	0.45
2	Area KT2	6.48	0.34
3	Area KT3	5.67	0.29
4	Area KT4	6.48	0.33
5	Area -G9-KT2-97,5	5.55	0.37
6	Area (-170-100)G9	5.91	0.36
7	Area KTCB 1	4.38	0.4
8	Area 06-G9 VuMon	7.17	0.33
9	Area -97.5-180	5.55	0.36
10	Area G9 Vu Mon	5.91	0.42

computation of  $I_r$  – leakage current which is formed from the above equations. The input data of the simulation is shown in Table 2.

Simulating results from Fig. 7 are input into programming block. The integrated and differential equations expressing the transient process of Fig. 8 are shown in equation 4.

$$\frac{2}{3}(L_{ba} + L_{cap})\frac{di_{ro}}{dt} + \frac{2}{3}(R_{ba} + R_{cap})i_{ro} + R_r i_{ro} + R_{cd}i_1 = u; \quad (4)$$

$$R_{cd}i_1 = \frac{1}{C_{cd}} \int i_2 dt;$$

$$R_{cd}i_1 = L_b \frac{di_3}{dt} + R_b i_3 + \frac{1}{C_b} \int i_3 dt;$$

$$i_{arc} = i_{ro} = i_1 + i_2 + i_3;$$

$$I_{arc} = \sqrt{\frac{1}{T} \int_0^T i_{arc}^2 dt};$$

$$R_{cd} = \frac{R}{3} = \frac{10^3}{0.096N + 0.04};$$

$$C_{cd} = 3C = (0.228L + 0.285)10^{-6};$$

$$Z_{ba} = \frac{10u_n U_{2dm}^2}{S_{dm}};$$

$$R_{ba} = \frac{10^3 P_n U_{2dm}^2}{S_{dm}^2};$$

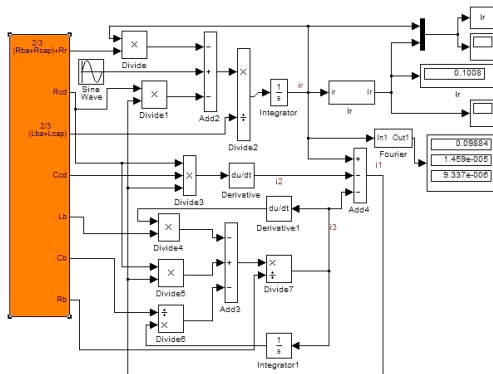

Fig. 7. The simulation to calculate  $I_r$  (current running through relay)

Table 2

Input grid's data for the simulation

$U_{nom}$ , kV	$S_{of\ transformer}$ , kVA	Number of equipment pieces connected to transformer, N	Length of 660V LV cables, m	Inductance of compensation coil of relay YAKI, H
0.69	320	15	1340	18

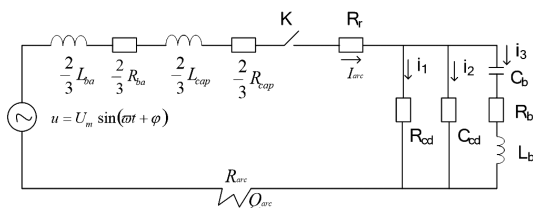

Fig. 8. Single line diagram of arcing circuit when one phase earthing in 660 V underground mine grids

$$L_{ba} = \frac{\sqrt{Z_{ba}^2 - R_{ba}^2}}{10^2 \pi};$$

$$R_{cap} = \frac{10^3 I_{xn}}{\gamma S} = \frac{10^3 I_{xn}}{50S};$$

$$L_{cap} = \frac{x_0 I_{xn}}{10^2 \pi};$$

$$x = U_m \sin(\omega t + \phi).$$

In the orange block and from equation 4, grid parameters are incorporated and transformed. They are:  $R_{ba}$  and  $L_{ba}$  – inductance and resistance of the transformer;  $R_{cap}$  and  $L_{cap}$  – inductance and resistance of cable from the source to the earth point;  $R_{cd}$  – insulation resistance of the grid;  $i_{ro}$  – leakage current running in the single line diagram, N – the number of equipment connected on 660 V of the transformer; L – the length of the grid energized by the transformer;  $Z_{ba}$  – the impedance of the transformer. The simulation to form  $I_r = f(N)$  corresponding to 3 compensating levels is shown in Fig. 9.

By varying the input data (N and L) corresponding to 3 alternatives of  $L_b$  – the inductance of compensation coil in leakage relay, three output blocks of earthing current  $I_{ro}$  are computed, the values of currents are utilized to form curves in Figs. 10 to 13. Fig. 10 shows the relation of  $I_r$  versus time with 3 compensation levels: no compensation (blue line with  $I_r \approx 18$  mA), partial compensation – 10 H (red line with  $I_r \approx 11$  mA); full compensation – 18 H (bubble line with  $I_r \approx 10$  mA).

Obviously, in Fig. 10, with the same grid's parameter the highest compensation value (3<sup>rd</sup> tap change–18 mH) will result to the lowest magnitude of leakage current (the bubble curves). The relations of  $I_r$  (vertical axis) versus the length of the grid (horizontal axis) with different connected apparatus (including VSD equipment) are presented in Figs. 11, 12 and 13. All values of  $I_r$  are referred to the allowance limit (10 mA [11, 15]). Fig. 11 shows the relation of  $I_r$  versus the length of 660 V LV cables with a variable number of motors/equipment (N) connected to the transformer when no compensation is implemented. In the figure, N varies from 5 to 40 motors.

In Fig. 11,  $I_r$  is much higher than 10 mA despite the length of the grid. This is the core reason why the grid's capacitance is so big (in 660 V) [5, 10]. Therefore, the recommendation is not to set the 1<sup>st</sup> tap of YAKI relay in 660V grid.

Similarly Figs. 12 and 13 show the relation of  $I_r = f(L)$  with variable N values corresponding to partial and full compensation.

In Fig. 12, when the relay is set on 2<sup>nd</sup> compensation tap changer, despite the length of the grid,  $I_r$  is lower than 10 mA if the connected apparatus N is less than 3. In case N is bigger than 5, the value of  $I_r$  is bigger than 10 mA with any length of the grid. The recommendation is as follows: Operators and managers should consider applying some other technical solution to protect human beings from danger of electric shock.

In Fig. 13, with highest inductance compensation level, operators have multiple choices to ensure electrical safety for human beings. The choice can rely on grid parameters corresponding to variable connected apparatus. For instance, if there are 10 equipment sets connected to 660 V grid (cyan coloured curve),  $I_r$  can only be bigger than 10 mA if the length of the grid is bigger than 1.5 km. It means that if the length of an underground mine is shorter than 1.5 km and the YAKI relay is operated with 3<sup>rd</sup> tap changer, it is considered that human beings are protected from electric shock when earth fault should arise. Therefore, the selection curves in Fig. 12 deliver strong recommendations for operators to select the optimal operating situation to ensure electrical safety.

**Conclusions.** By making combination of measurements of the grid's parameters, the simulations are implemented in Matlab to curves with different inductance compensation lev-



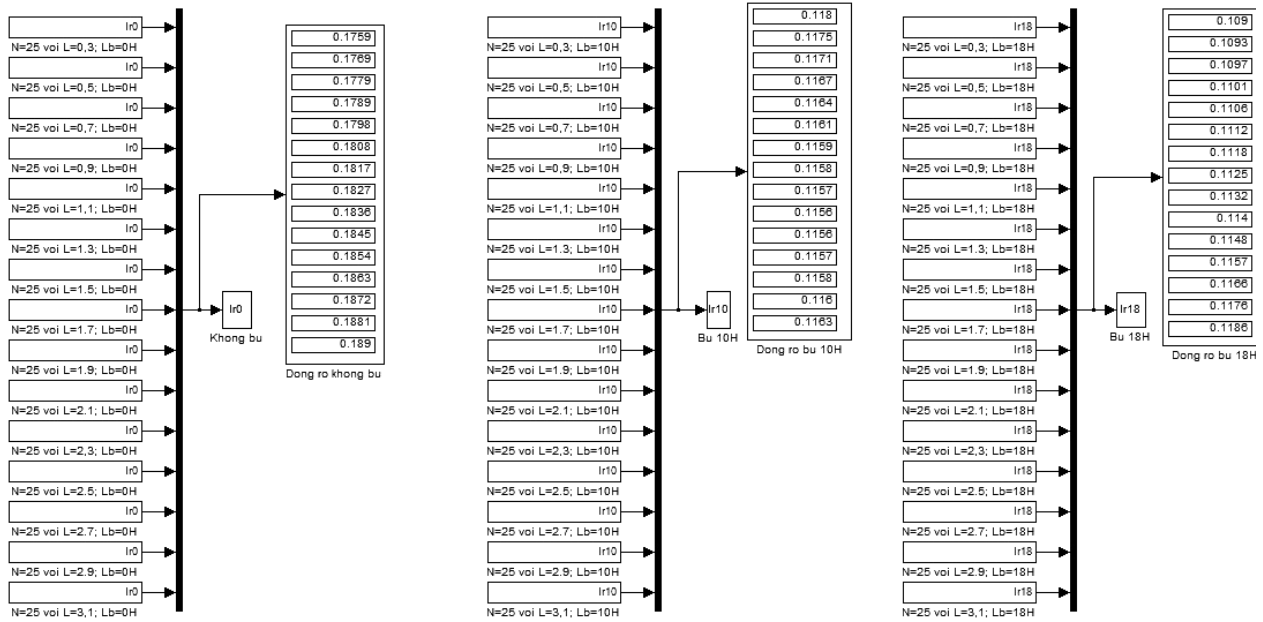

Fig. 9. The simulation to form  $I_r = f(N)$  corresponding to 3 compensating levels

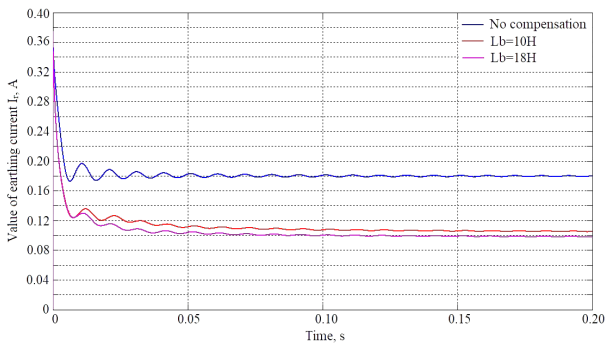

Fig. 10. Curves presented  $I_r = f(t)$  correspond to three compensation levels:  
red line  $I_r = f(t)$  corresponds to  $L = 10 H$ ; blue line  $I_r = f(t)$  corresponds to no compensation; bubble line  $I_r = f(t)$  corresponds to  $L = 18 H$

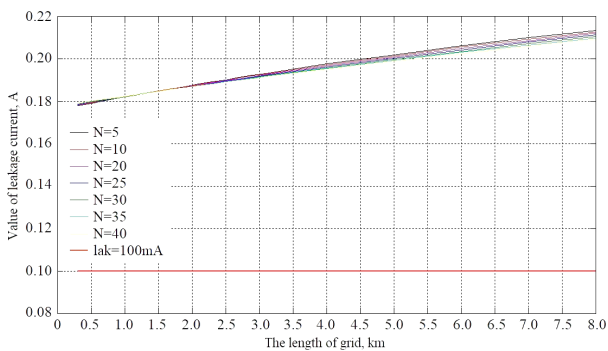

Fig. 11. The relation of  $I_r = f(t)$  corresponding to different connected apparatus ( $N$ ) When there is no inductance compensation on earthing relay (the 1<sup>st</sup> tap change)

els of earth leakage relay (0, 10 and 18 mH). Basing on curves, the recommendations have been developed for operators. By selecting suitable tap-changer of YAKII relay combine with different parameters of the grid, a conclusion about electrical safety could be formed depending on variety numbers of connection apparatus. This method is helpful for most Vietnam underground coal mines with serious electrical safety regulations and it is approved by VINACOMIN.

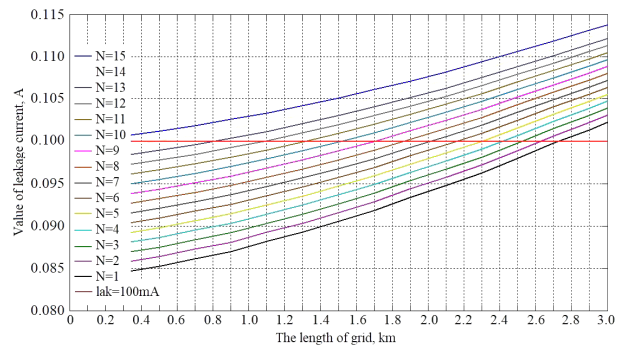

Fig. 12. The relation of  $I_r = f(L)$  corresponding to different connected apparatus ( $N$ ) when there is 10 mH inductance compensation on earthing relay (the 2<sup>nd</sup> tap change)

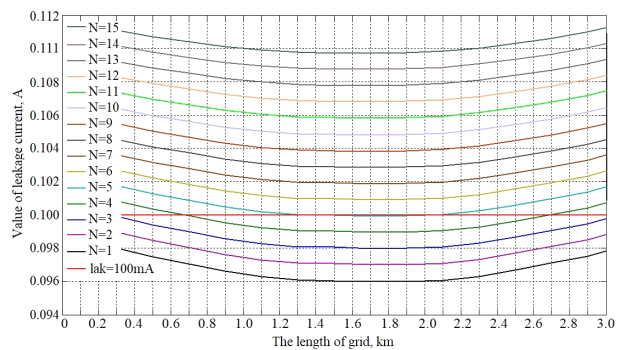

Fig. 13. The relation of  $I_r = f(L)$  corresponding to different connected apparatus ( $N$ ) when there is 18 mH inductance compensation on earthing relay (the 3<sup>rd</sup> tap change)

**Acknowledgements.** The authors of the paper would like to give special thanks to top managers of MongDuong underground coal mine, KheCham underground coal mine for great help and support in measuring the grid's capacitance and grid's insulation resistance.

#### References.

- VINACOMIN (2019). *Orientation for sustainable development of coal mining. Approved by Priminister Dcision No 403/2016/QĐ-TTg.* Retrieved from <http://www.vinacomin.vn/dinh-huong-phat-trien->

[ben-vung-nganh-than-viet-nam-gan-voi-dam-bao-an-ninh-nang-luong/dinh-huong-phat-trien-ben-vung-nganh-than-viet-nam-gan-voi-dam-bao-an-ninh-nang-luong-201901181507032041.htm](https://doi.org/10.11591/elektroteknika.v1i1i9.3267).

2. Hufnagi, E., Fickert, L., & Schmautzer, E. (2015). Efficient Calculation of earth fault currents in compensated networks. *Power engineering*, 1-17. Retrieved from <http://ke.powerlab.um.si/Arhiv/dokument.aspx?id=178>.
3. Gao, Y., Ma, F. L., Dong, G. Z., & Xing, H. L. (2014). Research on Centralized Short-circuit and Leakage Protection for High-voltage System of Underground Central Substation. *Applied Mechanics and Materials*, (494), 1753-1757. <https://doi.org/10.4028/www.scientific.net/AMM.494-495.1753>.
4. Niculescu, T., Arad, V., Marcu, M., Arad, S., & Popescu, F.G. (2020). Safety barrier of electrical equipment for environments with a potential explosion in underground coal mines. *Mining of Mineral Deposits*, 14(3), 78-86. <https://doi.org/10.33271/mining14.03.078>.
5. Qi, X., Lo, S. C., Gyure, A., Luo, Y., Shahrman, M., Singhal, K., & MacMillan, D. B. (2006). Efficient subthreshold leakage current optimization-Leakage current optimization and layout migration for 90- and 65-nm ASIC libraries. *IEEE Circuits and Devices Magazine*, 22(5), 39-47.
6. TCVN 6780-4, 2009, Ministry of Industry – National Technical Safety Regulation on Underground mines (n.d.). Retrieved from <https://tieuchuan.vsqi.gov.vn/tieuchuan/view?sohieu=TCVN+6780-4%3A2009>.
7. Wymann, T., Pollock, M., & Rees, J. (2015). A new approach to mining earth leakage protection with medium voltage drives. *Industrial-Electrix*, 24-27. Retrieved from [https://library.e.abb.com/public/581ec6f4334847f1a83e4ee8f693589a/MESC\\_ELR%20Paper\\_9AAK10I03A3924\\_RevA.pdf](https://library.e.abb.com/public/581ec6f4334847f1a83e4ee8f693589a/MESC_ELR%20Paper_9AAK10I03A3924_RevA.pdf).
8. Bottrill, G., Cheyne, D., & Vijayaraghavan, G. (2005). Practical electrical equipment and installations in hazardous areas. Elsevier press. <https://doi.org/10.1016/B978-0-7506-6398-4.X5000-9>.
9. Nguyen, K. T., Kim, L. N., Nguyen, S. T., & Nguyen, G. T. (2020). Research, design, manufacture leakage current protection device for 660 V/1140 V underground mine electrical networks. *Journal of Mining and Earth Sciences*, 61(5), 96-103. [https://doi.org/10.46326/jmes.2020.61\(5\).11](https://doi.org/10.46326/jmes.2020.61(5).11).
10. Tuan, N. G., & Tien, N. H. (2020). Research for determining insulation factors of 600V underground mining in area of Hon Gai. *Journal of Automation Today*. Retrieved from <https://vnautomate.net/nghien-cuu-xac-dinh-cac-thong-so-cach-dien-so-voi-dat-cua-mang-ha-ap-660v-mo-than-ham-lo-vung-hon-gai.html>.
11. *Coal Mining Safety and Health Regulation 2017, Part 4 Electrical activities, equipment and installations* (n.d.). Retrieved from <https://www.legislation.qld.gov.au/view/pdf/asmade/sl-2017-0165>.
12. *Safety Standards for Electrical Installations and Equipment in explosives facilities, JSP 482 MOD Explosives Regulations* (2016). Retrieved from [https://assets.publishing.service.gov.uk/government/uploads/system/uploads/attachment\\_data/file/529168/20160526-JSP\\_482\\_Edt4\\_1\\_Chapter\\_8.pdf](https://assets.publishing.service.gov.uk/government/uploads/system/uploads/attachment_data/file/529168/20160526-JSP_482_Edt4_1_Chapter_8.pdf).
13. *Vietnam National regulation on safety Mining, QCVN 01:2011/BCT* (2011). Retrieved from <http://www.kiemdinh.vn/upload/files/QCVN%2001-2011-BCT%20An%20toa%CC%80n%20trong%20khai%20tha%CC%81c%20than%20h%C3%A2%CC%80m%20lo%CC%80.pdf>.
14. Velimir Lackovic, *Grounding system Theory and Practice*, CED-Continuing Education and Development, Inc, Course E04-027 (n.d.). Retrieved from <https://www.cedengineering.com/userfiles/Grounding%20System%20Theory%20and%20Practice%20R1.pdf>.
15. Qiang, C., Ning, C., & Zhen-Shuang, L. (2013). Grounding Effect on Common Mode Interference of Underground Inverter. *Telkomnika Indonesian Journal of Electrical Engineering*, 11(9), 5187-5194. <https://doi.org/10.11591/telkomnika.v11i9.3267>.

16. Remash, B. (2004). Practical power system protection. *Mine underground distribution protection*, 184-196. Retrieved from <https://www.globalspec.com/reference/38528/203279/chapter-12-mine-underground-distribution-protection>.

17. AMPCONTROL (2013). *Mining earth leakage protection with variable speed drives*. Retrieved from <https://ampcontrolgroup.com/mining-earth-leakage-protection-with-variable-speed-drives/>.

## Аналіз і визначення обмежень параметрів мережі 660 В для забезпечення електробезпеки в підземних вугільних шахтах

Ле Суан Тхань, Хо В'єт Бун

Ханойський університет гірничої справи та геології, м. Ханой, Соціалістична республіка В'єтнам, e-mail: [lexuanthanh@humg.edu.vn](mailto:lexuanthanh@humg.edu.vn)

**Мета.** Вивчити зв'язок між блукаючим струмом і часом, а потім визначити деякі обмеження параметрів мережі для забезпечення електробезпеки й вибухобезпеки, що відповідають різним режимам роботи реле витоку в підземних шахтах В'єтнаму.

**Методика.** Мережі 660 В у підземних вугільних шахтах В'єтнаму – це електричні системи з ізольованими нейтраліями. Вони експлуатуються в дуже серйозних і жорстких умовах, включаючи питання електробезпеки й вибухобезпеки. За повсякденної експлуатації струми витоку на землю (струми замикання на землю) повинні бути нижчими за допустиму межу. Однак при використанні багатьох нових силових електронних пристроїв, таких як привід із регульованою швидкістю (VSD), кількість підключеного обладнання змінюється через зміну ємнісного струму. Після вимірювання параметрів мережі розраховали струми витоку для 3 рівнів компенсації реле захисту. Отримані значення струмів були використані для побудови граничних кривих.

**Результати.** Криві графіків показують співвідношення між струмом витоку та довжиною кабелів передачі, пов'язаних із різним сполучним обладнанням. Криві можуть бути використані для безпечної та ефективної експлуатації електричної системи.

**Наукова новизна.** Пропоновані рівняння та моделювання в MatLab можуть бути застосовані до всіх мереж підземних гірничих робіт із різними вхідними параметрами.

**Практична значимість.** Робочі криві графіків використовуються для визначення параметрів мережі, що найбільш підходять, які можуть забезпечити її електробезпеку (підтримка струму витоку в допустимих межах). Це може допомогти операторам або технічним фахівцям оптимізувати структуру мережі й забезпечити її безпеку.

**Ключові слова:** мережа 660 В, ізольована нейтраль, електробезпека, реле захисту, вугільні шахти

The manuscript was submitted 12.05.21.