

Ho Viet Bun,
orcid.org/0000-0003-2123-9179,
Le Xuan Thanh,
orcid.org/0000-0001-5052-4484

HaNoi University of Mining and Geology, HaNoi, the Socialist Republic of Vietnam, e-mail: lexuanthanh@humg.edu.vn

A NEW APPROACH TO IMPROVING THE SENSITIVITY OF EARTHING RELAY AND REDUCING THE OVER-VOLTAGE IN 6 KV GRID OF OPEN-PIT MINES

Purpose. Earthing relays are utilized very commonly in open-pit mines for disconnecting the failure part of 6 kV electric system from earthing incident. Much previous research is mentioned on searching either an optimal method for improving the effect of relays or improvements of reducing the overvoltage caused by grounding separately. The paper presents a new approach to not only improving the relays' sensitivity but also to limiting the over-voltage. A new algorithm is also proposed to control automatic connection of an additional resistor in order to achieve both above mentioned purposes of 6 kV earthing relay.

Methodology. The propose controlling diagram is implemented on PROTEUS to get $3U_0$ signals. The main components appeared when 6 kV feeders were faulted to earth. Afterward, the detecting signal is utilized as input for simulation diagram in MATLAB to get and analyze the wave forms of responded zero sequence voltage.

Findings. The paper presents a new algorithm utilizing a resistor that is auto-controlled to auto-connect the open-triangle coil of 6 kV measurement transformer at the moment of earth fault. This automatic connection aims to increase the relay sensitivity as well as reduce the overvoltage. The finding results are sensitivity factors of relay and voltage magnitudes of healthy phases, which will be compared with corresponding values when there is no connection of resistor to prove the effectiveness of the method.

Originality. A useful method is proposed for increasing the earthing current to enhance the sensitivity of earthing relay.

Practical value. The proposed control diagram could be used to design a device aiming to improve the safety of 6 kV grid in open pit mines when earth faults occur.

Keywords: 6 kV grid, open pit mine, sensitivity, over-voltage

Introduction. In Vietnam, earthing relays are utilized largely to protect electrical apparatus from earthed faults occurred in 6 kV system. This kind of fault is about 55 to 73 % of the total faults in 6 kV mining grids. In on-site operation, one phase earthed fault current could normally lead to flickering arc and over-voltage in two other phases left [1, 2]. The Safety Law of Vietnam requires solutions to decrease this bad effect [3].

Because of mining technology, the 6 kV grids of open-pit mines are constructed in skeleton or single routine diagram. To protect the earth faults, a relay is set up relying on zero sequence current or zero sequence voltage [4, 5]. To increase the reliability of the whole grid, sometime a recloser is equipped in the beginning part of a feeder (as can be seen in Fig. 1)

Fig. 1 depicts a typical setup of protection diagram on medium voltage grid to protect feeder from earthing. Most of circuit breaker located at the beginning end of feeder receive the tripping signal from earthing relays to operate. In some cases, because of high impedance of earth-fault point, the fault current is so small. Consequently, the relays are not sensitive enough to make the CB trip-open. To avoid these phenomena, many techniques could be applied such as designing a sensitive earth fault protector to release high impedance earth fault point or set-up another back up protection device [6].

Another proposed method is utilizing PTs which are mainly measurement devices to increase the fault current, then improve the sensitivity of earthing relay. Fig. 2 presents a kind of such PT. In the figure, a "zig-zag" earthing transformer is constructed. In faulted situations, the residual voltage could cause large and significant current running back through the PT [6].

As mentioned in [2, 3, 5] and [7], a 6 kV grid is an ungrounded one. Normally, the secondary winding of main 35/6 kV transformer are delta configured. To calculate the faulted current or faulted voltage at single line ground (SLG) fault, zero-sequence diagram are utilized. Fig. 3 presents a zero-sequence diagram that is also used to detect Zero sequence voltage (V_0).

Some studies in [8–10] showed that if earth fault relays operate on rms of fault current, relays (called over-current relays) could be malfunctioned or inefficient because of low value of earth fault currents. Therefore, to detect correctly the earth fault, all relays equipped with Vietnam 6 kV grids of open-pit mines must contain a special PT/VT (voltage transformer). This device contains 3 coils which are configured as $Y_0/Y_0/\Delta$ with broken coil. Across the coil the relay named 59N is connected (as shown in [6, 11]). The connection diagram of this special PT is illustrated in Fig. 4.

Another matter that 6 kV grid has faced is the over-voltage. As listed in [12, 13], the voltage in healthy phases could be over 1.7 times the nominal value. Particularly, if the flickering arc occurs, the over-voltage could be 3 to 6 times of rated voltage. Hence, the equipment on 6 kV grid could possibly be destroyed.

As it can be seen in [8–10], 2 big problems that electricians who operate 6 kV grids must seriously consider are:

- solving the fast response of relay to clear the earth fault with high sensitivity despite of type of neutral connection [14, 15];
- if earth fault occurs, the over-voltage must be limited to avoid the further damage on equipment in healthy phases.

Normally, above mentioned aims are solved separately with individual external equipment. The paper will introduce a new approach of not only increase the relay's sensitivities but

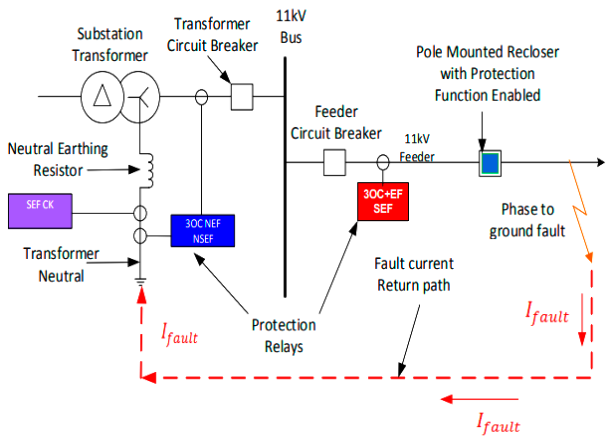

Fig. 1. Typical earth fault protection arrangement on MV feeders

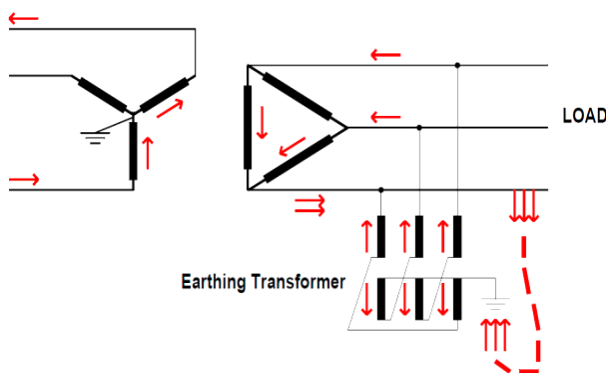

Fig. 2. Current running through zig-zag earthing transformer to increase the sensitivity of relay

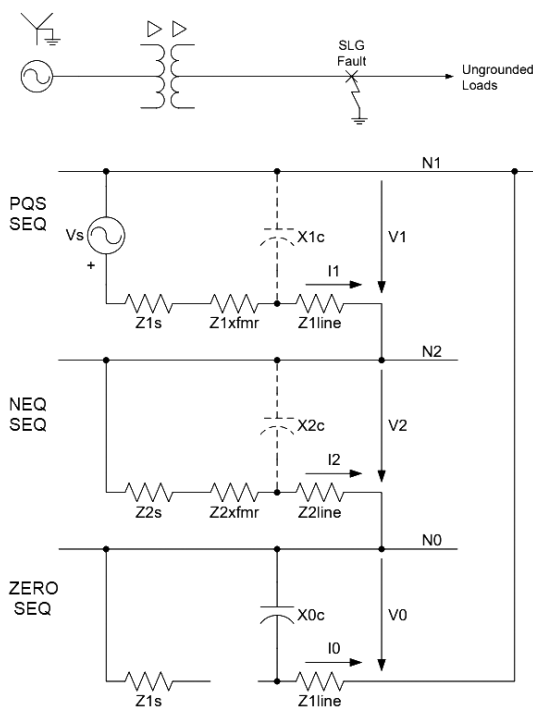

Fig. 3. Sequence diagrams showing the way to get zero sequence voltage

also limit the amplitude of over-voltage when earth fault happens. The method is proposed by making use of measurement devices (Potential transformers) with a small modification and does not affect the grid's structure.

Theoretical basis and proposed controlling technique. Determining the value of additional LV resistor for extra connection to PT in 6 kV. To recognize the earth-fault, two quantities are always supervised: zero-sequence voltage (U_0) and zero-sequence current (I_0) [5, 11, 15, 16]. These voltage and current signals are continuously measured by using CT (current transformers) and PT (Potential transformer). The latter one always contains broken coil for obtaining $3U_0$. This part will show the very small proposed connection of PT as well as the formulas expressing the calculation of $3U_0$ when the low voltage resistor (LVR) is connected. A proof of increasing the sensitivities of relays and limiting the magnitude of over voltage is presented in the next part. As can be seen in Fig. 5, by connecting a low voltage resistor (LVR) R_H across the broken coil of potential transformer (Fig. 5), the basis of neutral point characteristic is not changed. Furthermore, the connection followed up tightly the Safety Law [2, 3, 14]. The following part will show the calculation for determining the value of R_H from the grid's parameters.

In Fig. 5, the primary circuit of grid is not modified, only the measuring part is a little reformed; for on-site installation this small modification could be easily obtained. For handling the connection of the resistor, a microprocessor-controller is set up to R_H . To trip open or trip close, circuit breakers (CBs) located at the beginning end of feeders are installed (B1, B2, B3, B4 in Fig. 5). These CBs also receive zero sequence current and zero sequence voltage, the latter is detected by delta broken coil of potential transformer ($3U_0$).

To analyze the purpose of LVR, the equivalent diagram used to determine zero sequence current is shown in Fig. 6.

In Fig. 6, all impedances of transformers are computed in zero-sequence diagram. Those components and parameters of

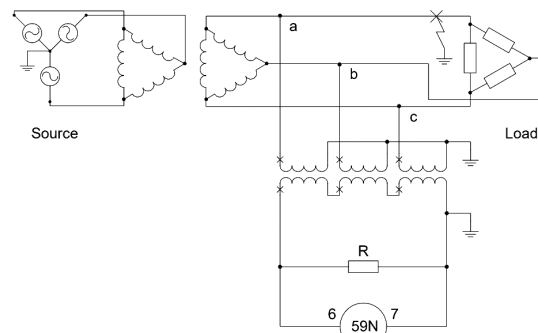

Fig. 4. Potential transformer with a broken delta coil used to detect zero-sequence voltage

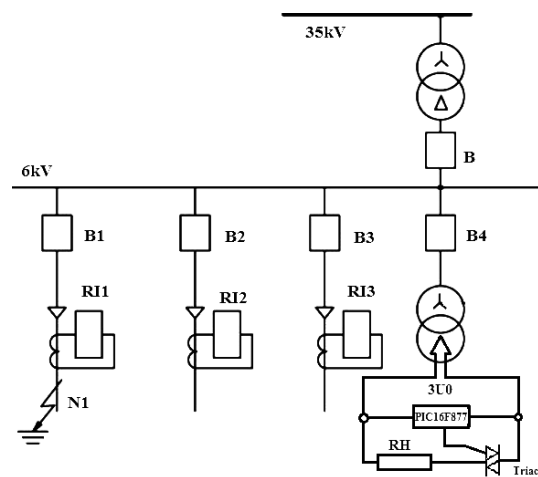

Fig. 5. Connection diagram of main 35/6 kV transformer substation with LVR connected to delta broken coil of PT

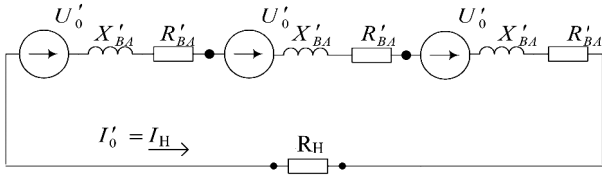

Fig. 6. The equivalent diagram of Fig. 1 with the connection of LV resistor (R_H)

above circuit are converted through the transformation ratio K_{BA} , [16]

$$U'_0 = K_{BA}^{-1} \cdot U_0; \quad R'_{BA} = R_{BA} \cdot K_{BA}^{-2}; \quad X'_{BA} = X_{BA} \cdot K_{BA}^{-2}; \quad (1)$$

$$I'_0 = I_H = \frac{3 \cdot U'_0}{3 \cdot (R'_{BA} + j \cdot X'_{BA}) + R_H}, \quad (2)$$

where R_H is LV resistor connected across the broken coil of PT; K_{BA} is the transformed ratio of PT; R_{BA} and X_{BA} are resistor and reactor of PT; R_H is converted from R_C [16], which are calculated by estimating the active power consumption on the resistor (when earth fault happens) [7]

$$(3 \cdot |I_0|)^2 \cdot R_C = |I'_0|^2 \cdot R_H = (|I_0| \cdot K_{BA})^2 \cdot R_H, \quad (3)$$

where R_C is the resistor connected at the neutral point of high voltage side of the power transformer.

As shown in [13], the equation (3) is obtained from equation (4) – the formula expressing the energy equivalent on resistor at earthing procedure

$$\left(\frac{U_f}{R_C}\right)^2 \cdot R_C = \left(\frac{3 \cdot U_f}{K_{BA} \cdot R_H}\right)^2 \cdot R_H. \quad (4)$$

Therefore,

$$R_H = \frac{9 \cdot R_C}{K_{BA}^2}. \quad (5)$$

Equation (5) shows the way to determine the value of R_H for additional connection, in normal operating modes, its energy consumption presented in equation (6) is very small and could be ignored [7]. In a specified 6 kV grid, it is possible to get the value of additional connection resistor from the grid's parameters. The impact of the value and its effectiveness on reducing the over voltage will be analyzed in the latter part of paper.

$$P_H = \frac{9 \cdot U_f^2}{K_{BA}^2 \cdot R_H}. \quad (6)$$

Propose controlling technique. Relying on the value calculated by equation (5), implementing the simulation by on-time connect a LVR right at the moment of one phase faulted to earth, a block diagram is proposed in Fig. 7. In this figure, $3U_0$ is the main input signal for controlling the switching procedure the connection of R_H . An isolate block is also added in order to not modify the basis of neutral point on 6 kV side of transformer.

In this figure, the switching signals operate R_H on or off base on TRIAC controlled circuit. Utilizing this type of switching replacing for electro-mechanic relay switching could reduce the operating time in order to meet the requirement of maximum tripping time (not longer than $T/4 = 5$ ms) [17]. Utilizing TRIAC KS200A controlled by microprocessor PIC 16F887, a fault detector Algorithm is shown in Fig. 8. In the figure, the zero-sequence value of voltage (measured by broken coil of PT) is continuously supervised to detect if earthing has risen. This voltage is compared with setting value U_{set} for tripping open or tripping close the CB by TRIAC signals. The operation of controlling circuit is simulated in PROTEUS shown in Fig. 9.

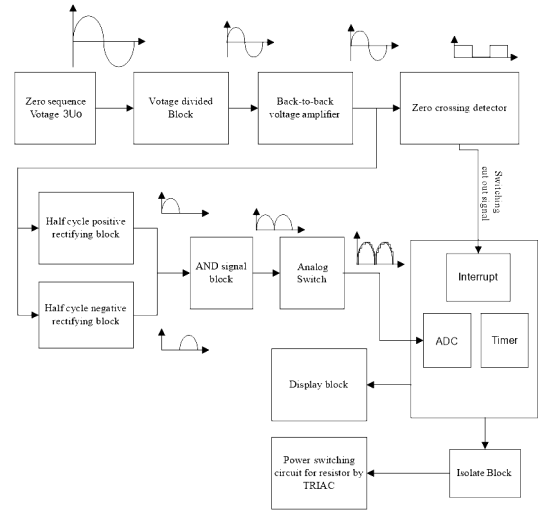

Fig. 7. Propose diagram for controlling on-time connect of LV resistor

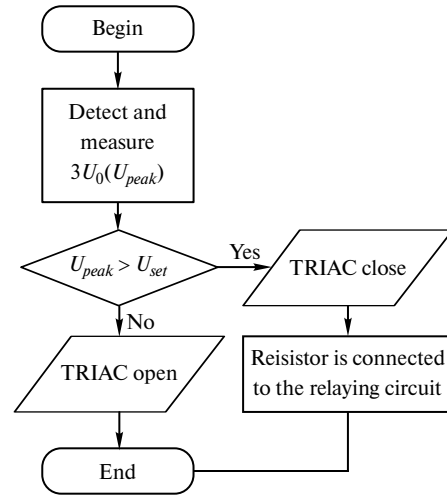

Fig. 8. Block diagram presenting the fault detecting algorithm

Figs. 8, 9 present the controlling procedure that connect R_H on the very right moment to meet the following aims:

- to detect $3U_0$ for emitting the tripping signal;
- to increase the fault current to enhance the sensitivity of earthing relay;
- to reduce the root mean square (rms) of phasor voltage on healthy phases.

The next part of the paper will demonstrate the usefulness.

Simulation results and discussion. To meet the demand of the relay system, total response time of sub-equipped apparatus will not be over 1 ms [5, 16, 18]. The following part will show the simulation and the computation of the response time of relay with the connection of LV resistor (R_H). In Fig. 9, voltage $3U_0$ passes the divided part composed by Rv1 and Rv22 to obtain the input voltage for OPMP LM393.

When $3U_0$ is smaller than U_{set} , the pole 30 (RD7/PSD7) of microprocessor is 0 (zero). Hence, there is no signal fed to Opto MOC3021. Consequently, there is no pulse on G pole of the TRIAC. TRIAC is blocked, and there is no current flow through R_H . The setting up procedure for $3U_0$ is on Sine Generator block with the following factors:

- analogue types: sine;
- amplitude of $3U_0$: 1 kV (its maximum allowance value);
- frequency (Hz): 50 Hz;
- delay of phase angle: 0 degree.

The result of voltage waveform is shown in Fig. 10. When $3U_0$ is bigger than U_{set} , the pole 30 of microprocessor is flagged

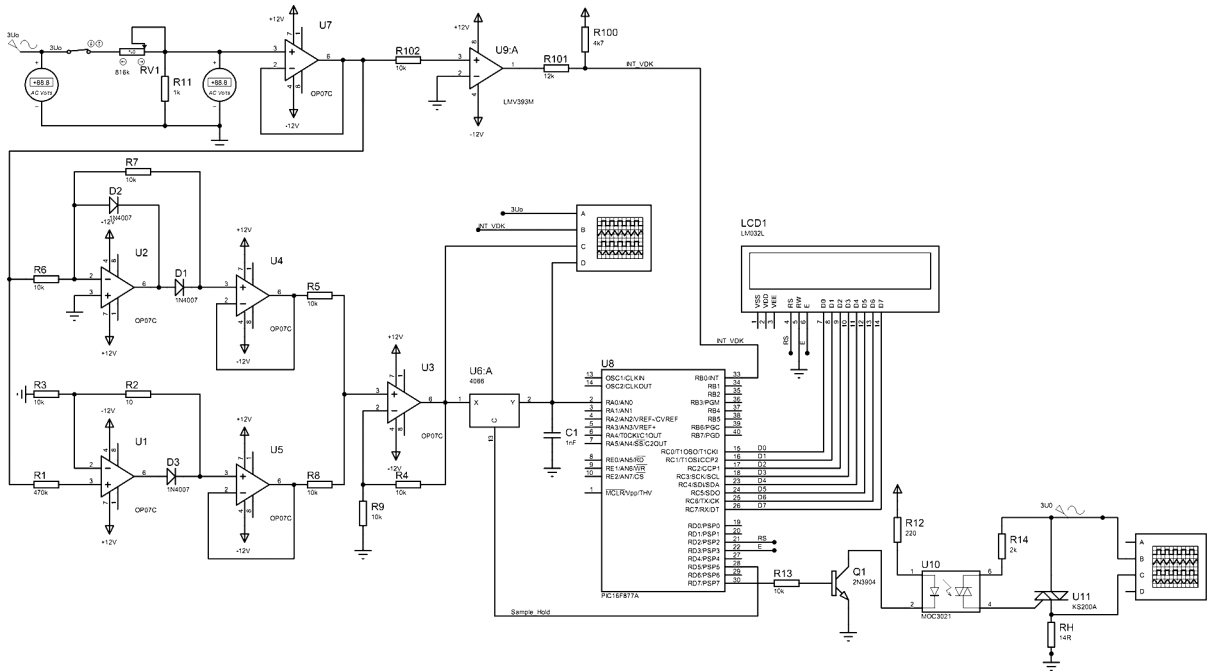

Fig. 9. Controlling circuit simulated in PROTEUS software

up to 1, BJT 2N3904 conduct. Hence, there is signal over Opto MOC3021; therefore, TRIAC also conducts, there is a flowing current through R_{Hf} . Voltage waveform crossing R_{Hf} is shown in Fig. 11; output signal of zero crossing detector block is presented in Fig. 12. Increasing the value of $3U_0$ to 2 kV, the measurement circuit is still functional, the result is obtained, simulated and presented in Fig. 13.

Corresponding to the response time of OPAM (1.3 μ s), OPTO MOC3021 (5 μ s), others including sampling time, computing time of micro-processor is lower than 500 μ s, this leads to total response time of the circuit being less than 1 ms [5].

To estimate the effectiveness of the proposed RH connection method, a simulation diagram in MATLAB is implemented (Fig. 13).

In Fig. 13, there are 4 feeders with centralized load located at the end of feeders. There are also 4 fault-creator blocks to simulate the earthing procedure. A block aiming at detecting the zero-crossing moment is installed at 6 kV bus-bar. After detecting the fault, a control signal is emitted for closing RGRH (at the bottom of Fig. 13). The content of the controlling block is shown in Fig. 14. In Figs. 13, 14, there are 3 blocks of over-voltage relays ($RUA>$, $RUB>$ and $RUC>$), they are connected and incorporated with a subsystem for controlling the switching of RGRH. At earthing mode, there is signal for closing RU_0 (block 4), the signal also closes the contactor $RU13$ (in subsystem in Fig. 14). This parallel closing will make RGRH

tripping close. At the same time there are signals on $RUA>$ and $RUB>$, they are greater than the setting values. Hence, the contactors of $RUA>$ and $RUB>$ are closed, the contactors $RU4$, $RU7$ open, therefore RGB and RGC are deenergized to energize RGA. The relay will close the short-circuited contacts of phase A at beginning ends of the faulted feeder. Another signal

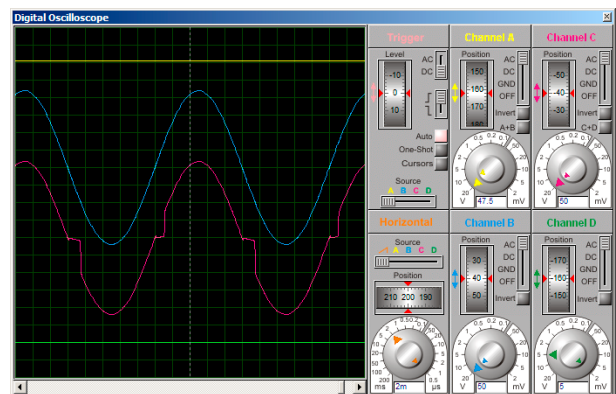

Fig. 11. AC voltage $3U_0 = 1 \text{ kV}$ (Cyan color) and output voltage across switching resistor

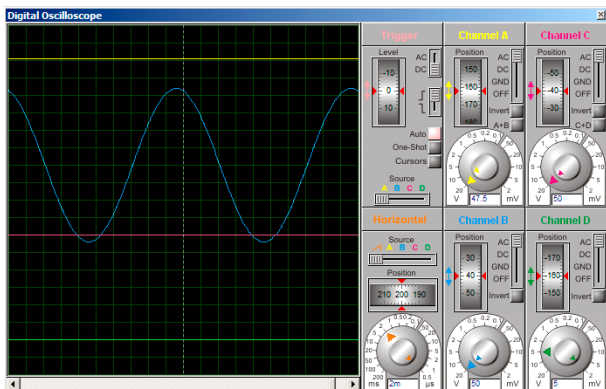

Fig. 10. Voltage waveform $3U_0 = 9 \text{ V}$ (Cyan color)

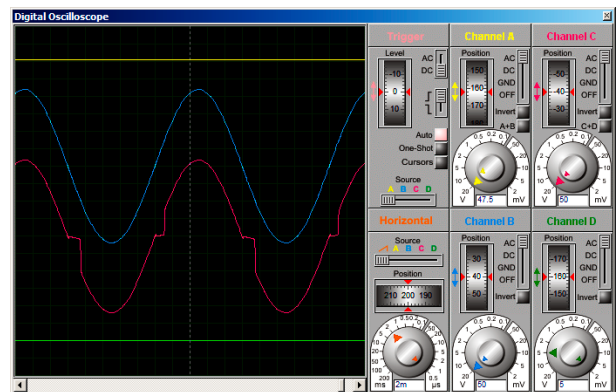

Fig. 12. Voltage waveform of $3U_0$, output signal of Zero crossing detector block

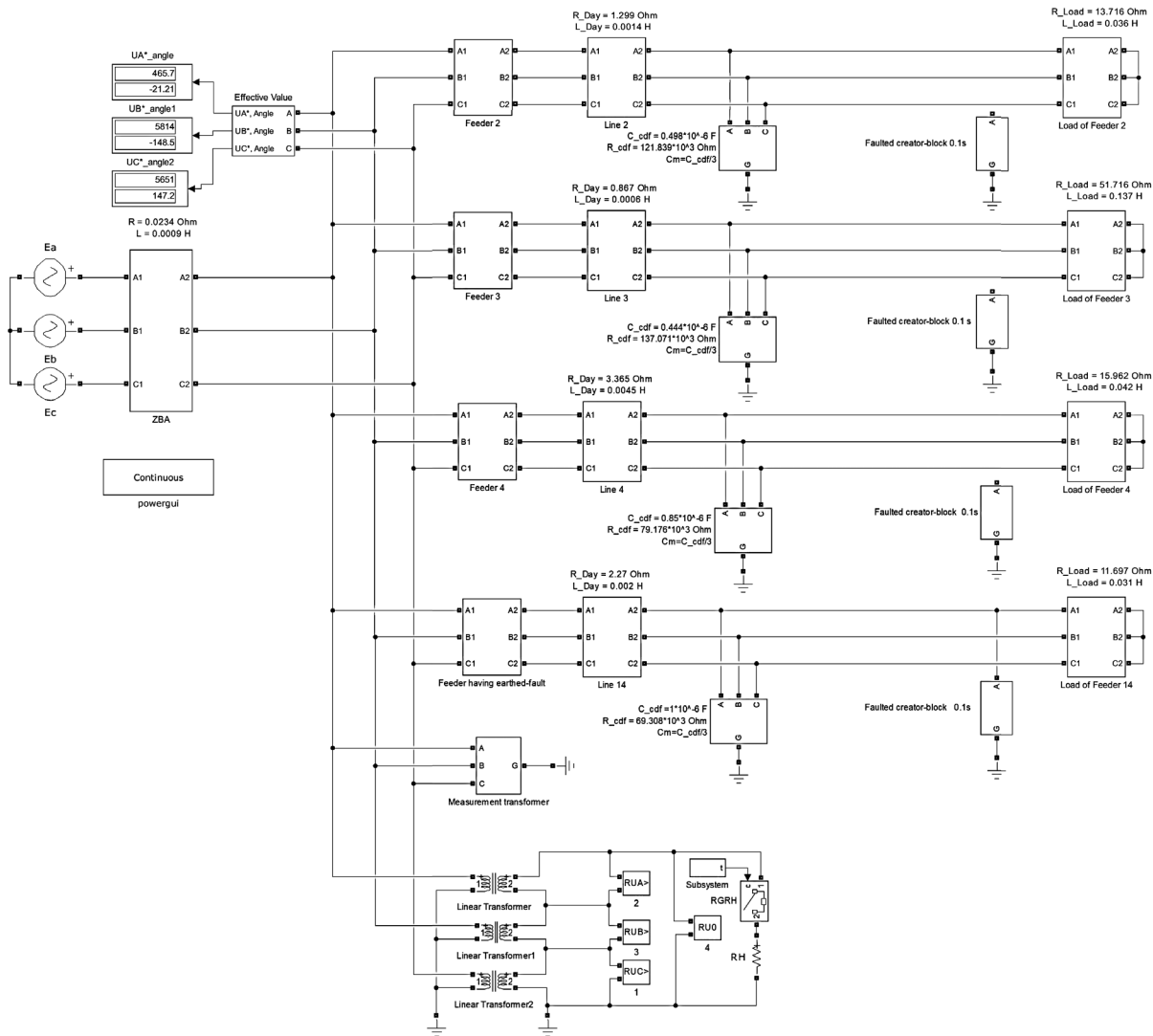

Fig. 13. Simulation diagram in MatLab to determine the rms and waveform of zero-sequence current and zero-sequence voltage

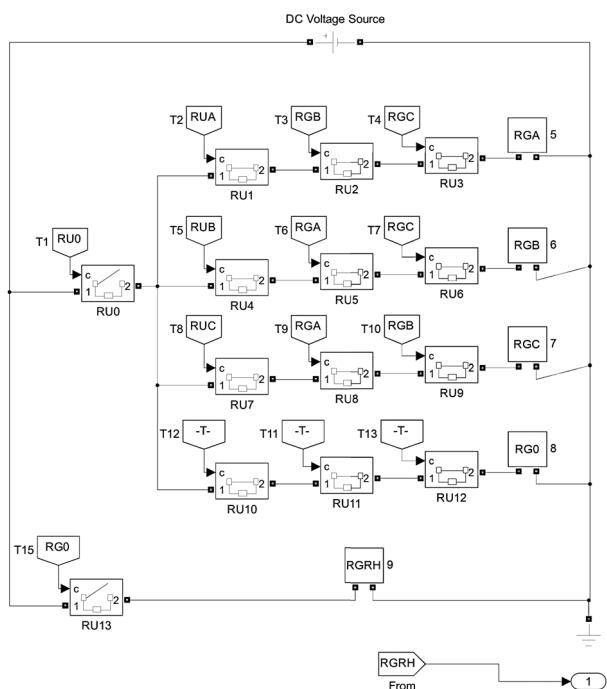

Fig. 14. Block of detecting zero crossing moment for closing R_H

is sent to T12 to energize for opening R_{H10} in order to disconnect R_H when the fault is cleared.

Implementing the simulation on MatLab, the waveforms of current running on earthing relay is shown in Fig. 15.

In Figs. 15, *b*, *c*, the upper curve (15, *b*) shows the waveform of earthing current (I_a) without R_H connection, while the lower curve (15, *c*) shows waveform of earthing current (I_b) with R_H connection. Obviously, the rms of I_b is bigger than I_a .

The increase ratio is approximately $\sqrt{2}$. It means that the sensitivity of earthing relay will be increased by $\sqrt{2}$ correspondingly. The transient processes of currents in 2 cases are mostly the same, there is no delay on forming sine waves of both I_a and I_b . In the earthed phase (Fig. 15, *a*), the current is mostly zero. The simulation results of voltage transient with and without the connection of R_H is shown in Fig. 16.

Another impact of R_H connection method is decrease in the rms of over voltage. Making the simulation with and without R_H connection, the resultant waveforms showing voltages on healthy phases are presented in Figs. 16, 17.

Fig. 16 presents various waveform expressing the response of voltage and current on healthy phases as well as earthed fault without R_H connection. With assumption that phase A is faulted to earth, it results in the increase in voltage in 2 other healthy phases. Fig. 16, *a* shows the voltage waveforms of phase B and C in per unit value. In the time from 0.057 to 0.95 s, it is clearly seen that the voltages of phase B and C is 4

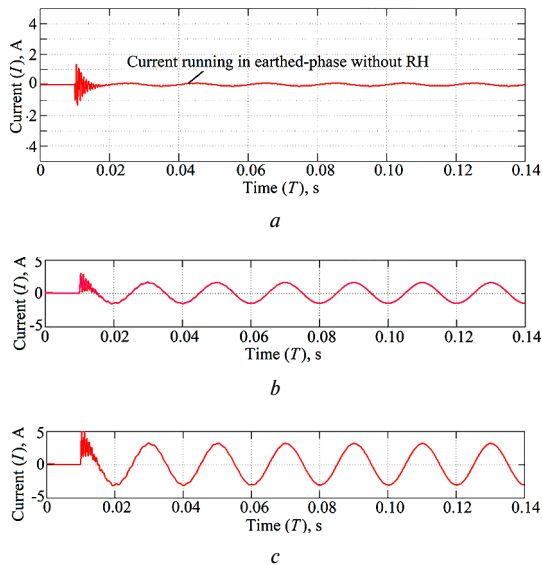

Fig. 15. Current waveforms running into earthing relay:
a – on earthed phase; *b* – current on healthy phase without R_H connection; *c* – current on healthy phase with R_H connection

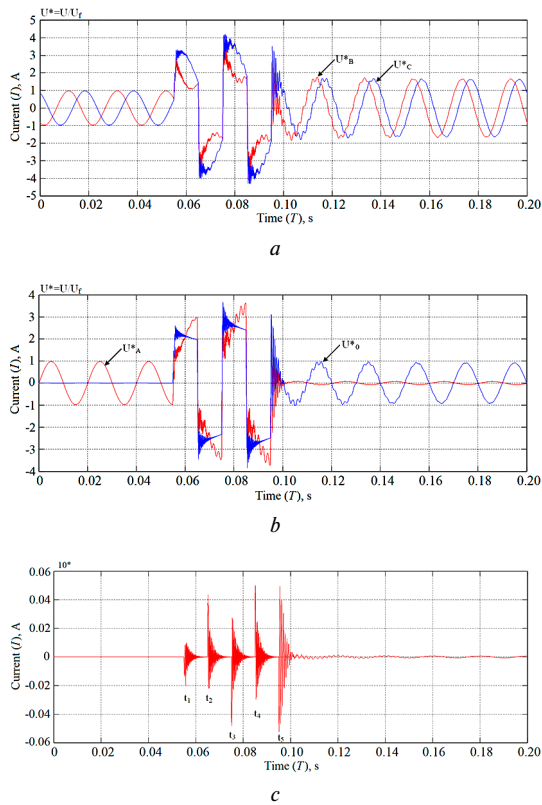

Fig. 16. Voltage waveform, current waveform on phase at earthing interval of time (without R_H connection):
a – voltages on healthy phases; *b* – zero-sequence voltage and voltage waveform on earthed phase (phase A); *c* – zero-sequence current on phase A

times risen to nominal voltage current waveforms. At the same interval of time when the earth fault phenomenon occurs (at $t = 0.05$ s) there is a sharp increase in zero-sequence voltage on phase A, after the transient procedure, U_0 is around 1 pu (the blue curve). Correspondingly, in Fig. 16, *c* zero-sequence current at examining interval (from 0.057 to 0.95 s) is also presented in Ampe.

Similarly to Figs. 16, *a*, *b*, 17, *a* presents the response of voltage waveforms on healthy phases (phase B and C). The

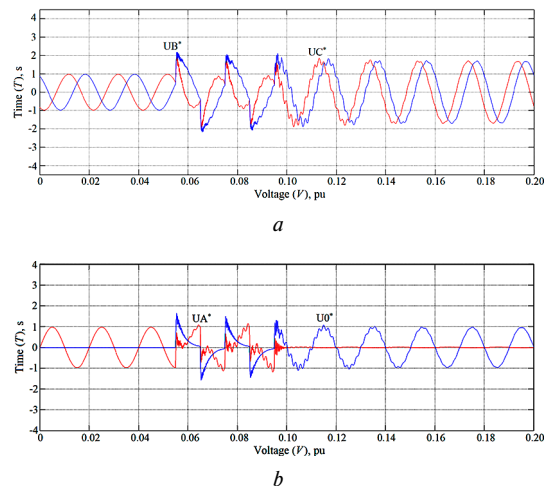

Fig. 17. Voltage waveform:
a – on healthy phases with R_H connection; *b* – voltage waveform and U_0 wave-form on phase A (faulted phase)

earthing interval is also from 0.57 to 0.95 s. Other voltage values of phase A (faulted phase) are also shown in Fig. 17, *b* to compare with those in Fig. 16, *b*.

The effectiveness of R_H in terms of decreasing the rms overvoltage is significantly shown by comparing Figs. 16, 17.

In Figs. 16, *a* and 17, *a*, the voltages of healthy phases are strongly decreased. In Fig. 16, *a*, this value is nearly 4 pu (per unit). It means that the overvoltage is 4 times bigger than U_{nom} . By utilizing R_H connection, in Fig. 17 this value is only 2 pu, the rms of voltages across equipment of healthy phases reduced by 2 times. This advanced advantage is prior to lengthen the aging of 6 kV apparatus.

In Figs. 16, *a* and 17, *a*, the rms of zero sequence voltage is mostly the same. It means that the operation of relay relying on this quantity is not affected despite of connect or disconnect R_H .

Conclusions. The paper presented a proposed method to increase the sensitivity of earthing relay on 6 kV mining grid by connecting the resistor right at the moment of earthing. The connection is controlled and programmed by microprocessor with a new algorithm applied for PIC 16F877. This additional connection did not modify the basis of the grid's neutral point and it is easily implemented with making use of existing measurement transformer PT.

Utilizing R_H connection brings the following advantages to the relay system and 6 kV electrical apparatus:

1. In healthy phases, the magnitude of over-voltages is only $(1.5-2.1)U_f$. The values are significantly reduced and fall within accepted level with 6 kV apparatus. Comparing the values of over-voltage without R_H connection [4, 7, 8], these quantities reduced nearly by 100 % $((3.2-4.2)U_f$ compared with $(1.5-2.1)U_f$).

2. The sensitivity of earthing relay is increased $\sqrt{2}$ because the earthing current is increased $\sqrt{2}$ when R_H connection method is utilized.

The simulation in Figs. 16, 17 (with $C = 2.791 \mu\text{F}$ and $R_H = 14 \Omega$) proves greatly the effectiveness of the proposed method. On flickering earthing, the significant reducing of magnitude of over-voltage (from 4 lower to 2.3) is superior advanced on the field of lengthen the life-time of 6 kV mining apparatus. The connection also brings the advantages of:

- eliminating the resonance occurring in 6 kV grid with incident current lower 3A;
- limiting the over-voltage rising on starting procedure of 6 kV motors (which cause phenomena like earthing).

Utilizing R_H connection could bring some other advances such as: reasonable price, small dimension (for easy installation), outdoor and indoor installation properties and simple

switching principle. Further on-site investigation should be done to prove the effectiveness of the method.

Acknowledgements. The authors of paper would like to give special thanks to top managers of DeoNaiopen-pit coal mine, NuiBeo open-pit coal mine for great help and support in measuring 6kV grid's parameters for the input of simulations.

References.

1. QCVN 01:2011/BCT, 2011. Vietnam National regulation on safety Mining (n.d.). Retrieved from <http://www.kiemdinh.vn/upload/files/QCVN%2001-2011-BCT%20An%20toa%CC%80n%20trong%20khai%20tha%CC%81c%20than%20h%C3%A2%CC%80m%20lo%CC%80.pdf>.
2. Thanh, L. X., & Bun, H. V. (2021). Identifying the efficiency decrease factor of motors working under power harmonic in 660 V electric mining grids. *Mining of Mineral Deposits*, 15(4), 108-113. <https://doi.org/10.33271/mining15.04.108>.
3. TCVN 6780-4, 2009, Ministry of Industry National Technical safety Regulation on Underground mines (n.d.). Retrieved from <https://tieuchuan.vsqi.gov.vn/tieuchuan/view?sohieu=TCVN+6780-4%3A2009>.
4. Bekbaev, A. B., Sheryshev, V. P., Sarsenbaev, E. A., & Kalikasov, N. T. (2021). Intellectualization of the process of measuring the temperature of inaccessible surfaces of electric contact connections. *Vestnik KazNRTU*, 172-179. <https://doi.org/10.51301/vest.su.2021.i4.22>.
5. Narayan, S. (2019). *Earthing Systems and Earth Fault Protection in Power System Distribution Network*. Research Project report, University of Southern Queensland. Retrieved from https://eprints.usq.edu.au/43125/12/Narayan_S_Quinton_Redacted.pdf.
6. Ghanbari, T., Samet, H., & Ghafourifard, J. (2016). New approach to improve sensitivity of differential and restricted earth fault protections for industrial transformers. *IET Generation, Transmission & Distribution*, 10(6), 1486-1494. <https://doi.org/10.1049/iet-gtd.2015.1343>.
7. Rorabaugh, J., Swisher, A., Palma, J., Andaya, G., Webster, M., Kirkpatrick, B., & Tran, T. (2020). Resonant Grounded Isolation Transformers to Prevent Ignitions From Powerline Faults. *IEEE Transactions on Power Delivery*, 36(4), 2287-2297. <https://doi.org/10.1109/TPWRD.2020.3030220>.
8. Bun, H. V., & Thanh, L. X. (2019). Impact of power harmonics on precise and discriminative tripping of the relay system for earthing protection in underground 6 kV grids of Qung Ninh underground mines. *Empowering Science and Mathematics for Global Competitiveness*, (2-4), 28-34. <https://doi.org/10.1201/9780429461903-5>.
9. Topolánek, D., Toman, P., Orságová, J., Kopicčka, M., & Dvořák, J. (2014). The evaluation of overvoltage during short-time additional earthing of healthy phase for fault location in MV networks. *Developments in Power System Protection*, 48-56. <https://doi.org/10.1049/cp.2014.0160>.
10. Sutherland, P., & Mansoor, A. (2005). A new method for testing and calibration of high-resistance grounding systems. *Electricity Distribution*, 1-4. <https://doi.org/10.1049/cp:20051165>.
11. Chabrol, A., & Hunt, S. (2015). Assessment of logic algorithms for faulted phase earthing protection relays on 10 kV networks. *Electricity Distribution*, 15-18, 0044.
12. Bun, H. V., & Thanh, L. X. (2016). An effective solution for reducing the overvoltage level when there is an one phase earthing on 6 kV grids of cement manufacturing enterprises. *Electro-mechanics for Mining and Geo-resources Development*, 91-99.
13. Kadyrov, A. S. (2017). Protection of 6–35 kV grids against overvoltage, selection of the neutral mode according to the overvoltage criterion. *Izvestiya Kyrgyzskogo gosudar-stvennogo tekhnicheskogo universiteta*, (4), 138-145.
14. Ermolaev, V. A., Potapchuk, N. K., & Zaydullina, K. A. (2018). Neutral grounding modes in electrical systems. *Electrical Complexes and Systems*, 203-206.
15. Sinchuk, O., Sinchuk, I., Beridze, T., Filipp, Y., Budnikov, K., Dozorenko, O., & Strzelecki, R. (2021). Assessment of the factors influencing on the formation of energy-oriented modes of electric power consumption by water-drainage installations of the mines. *Mining of Mineral Deposits*, 15(4), 25-33. <https://doi.org/10.33271/mining15.04.025>.

16. Suhono, S., Purnama, H., & Utomo, H. B. (2019). Ground fault protection using open break delta grounding transformer in ungrounded system. *Logic. Jurnal Rancang Bangun dan Teknologi*, 19(1), 34-40. <https://doi.org/10.31940/logic.v19i1.1275>.

17. Hufnagl, E., Fickert, L., & Schmutzner, E. (2015). Efficient calculation of earth fault currents in compensated networks. *Komunalna Energetika – Power Engineering*. Maribor, Slovenia. Retrieved from <https://graz.pure.elsevier.com/en/publications/efficient-calculation-of-earth-fault-currents-in-compensated-netw>.

18. Lowczowski, K., Lorence, J., Andruszkiewicz, J., Nodolny, Z., & Zawodniak, J. (2019). Novel Earth Fault Protection Algorithm Base on MV Cable Screen zero sequence current filter. *Energies*, 12(16), 3190. <https://doi.org/10.3390/en12163190>.

Новий підхід до підвищення чутливості реле заземлення та зниження перенапруги в мережах 6 кВ кар'єрів

Хо Віет Бун, Ле Сюань Тхань

Ханойський університет гірничої справи та геології, м. Ханой, Соціалістична Республіка В'єтнам, e-mail: lexuanthanh@humg.edu.vn

Мета. Реле заземлення широко використовуються у відкритих кар'єрах для відключення пошкодженої частини електричної системи 6 кВ від випадків замикання на землю. Згадується багато попередніх досліджень із пошуку або оптимального методу поліпшення дії реле, або поліпшення, спрямованого на зниження перенапруги, викликаної заземленням, індивідуально. У роботі наведено новий підхід не тільки до підвищення чутливості реле, але й до обмеження перенапруги. Запропоновано також новий алгоритм управління автоматичним підключенням додаткового резистора для досягнення обох перерахованих вище цілей реле заземлення 6 кВ.

Методика. Пропонована схема керування реалізована на основі PROTEUS для отримання $3U_0$ сигналів. Основні компоненти з'явилися при короткому замиканні на землю живильного пристрою в 6 кВ. Після цього сигнал пошуку використовується в якості вхідних даних для схеми моделювання у MATLAB з метою отримання та аналізу форм хвилі напруги спрацьовування нульової послідовності.

Результати. У роботі представлено новий алгоритм, що використовує резистор з автоматичним керуванням для автоматичного підключення обмотки розімкнутого трикутника вимірювального трансформатора 6 кВ у момент короткого замикання на землю. Це автоматичне підключення спрямоване на підвищення чутливості реле, а також зниження перенапруги. Результатами знаходження є коефіцієнти чутливості реле та величини напруги справних фаз, що порівнюватимуться з відповідними значеннями за відсутності підключення резистора для доказу ефективності методу.

Наукова новизна. Запропоновано метод збільшення струму заземлення для підвищення чутливості реле, що заземляє.

Практична значимість. Запропонована блок-схема алгоритму може бути використана для розробки пристрою, спрямованого на підвищення безпеки мережі 6 кВ у кар'єрах за короткого замикання на землю.

Ключові слова: мережа 6 кВ, кар'єр, чутливість, перенапруга

The manuscript was submitted 21.06.21.