

20. Takazawa, K., Tanaka, N., Fujita, M., Matsuoka, O., Saiki, T., Aikawa, M. et. al. (1998). Assessment of Vasoactive Agents and Vascular Aging by the Second Derivative of Photoplethysmogram Waveform. *Hypertension*, 32 (2), 365–370. doi: <https://doi.org/10.1161/01.hyp.32.2.365>
21. Askarian, B., Jung, K., Chong, J. W. (2019). Monitoring of Heart Rate from Photoplethysmographic Signals Using a Samsung Galaxy Note8 in Underwater Environments. *Sensors*, 19 (13), 2846. doi: <https://doi.org/10.3390/s19132846>

The reasons for the creation of a modern psychodiagnostic system are considered. The design and implementation of an information processing system using the structure of the reference model of the Internet of Things is proposed. The existing psychodiagnostic tools and a number of disadvantages are described. In the process of developing the system design, requirements were formed: three-dimensional representation of signals, remote control of the diagnostic process, data collection, transmission and storage on a remote server, processing of results, expert assessment. The main two tasks of the study are formed. The structure of an information processing system containing four blocks interacting with each other is presented. The principle of operation of the system provides for the transfer of data for testing and saving the results on a cloud server using WiFi or GPRS connection. The Thingspeak cloud service used provides guaranteed access to research data "anytime and from anywhere in the world." Data exchange occurs every 15 seconds when using the free version and with a cycle of up to 1 second when using the cloud on a commercial basis. The models of LED-cube, LED-ball, LED panels diagnosed using addressable digital RGB LEDs with built-in WS2812B microcontrollers (PRC) have been developed. A method for assessing the influence of various types of load on the functional state of a person is proposed. Scenarios of data processing for the formation of a subject's profile in the case of unclear classes are considered. The importance of developing such a system lies in the possibility of using various types of communication for data transmission and the ability to adapt it to non-standard research requirements

Keywords: *Internet of Things, microcontroller, WiFi module, GSM module, information processing system, psychodiagnostic research, fuzzy sets*

UDC 004.35: 004.9

DOI: 10.15587/1729-4061.2021.230042

INFORMATION PROCESSING PSYCHODIAGNOSTIC SYSTEM: DESIGNING AND IMPLEMENTATION

Valentine Lazurik

Doctor of Physical and
Mathematical Sciences, Professor
Department of Systems and Technologies Modeling**
E-mail: mst@karazin.ua

Nicolay Styervoyedov

Doctor of Technical Sciences, Associate Professor,
Head of Department*
E-mail: keus@karazin.ua

Natalia Varlamova

Lecturer*

E-mail: natess123@gmail.com

*Department of Electronics and Control Systems**

**V. N. Karazin Kharkiv National University
Svobody sq., 4, Kharkiv, Ukraine, 61022

Received date 09.02.2021

Accepted date 19.04.2021

Published date 30.04.2021

How to Cite: Lazurik, V., Styervoyedov, N., Varlamova, N. (2021). Information processing psychodiagnostic system: designing and implementation. *Eastern European Journal of Enterprise Technologies*, 2 (9 (110)), 45–54. doi: <https://doi.org/10.15587/1729-4061.2021.230042>

1. Introduction

The problems of the relationship between the psychological and psychophysical characteristics of a person and its effective work activity still require careful study. These interrelationships are relevant in all professional activities, but they are especially important in the operation of critical systems, in which the human factor can lead to a malfunction of the system, and, as a consequence, large losses [1, 2]. Accordingly, there is a requirement for fast and reliable hardware data collection, which, in turn, gives rise to the need to develop a modern psychodiagnostic and psychophysical information processing system.

Despite the development in recent years of the concept of the Internet of Things, which makes it possible to remotely control technical means [3–5], mainly hardware and software methods and means for local collection, storage and processing of data are used. These psychodiagnostic tools allow using a fairly large volume of tests, storing data on a local drive, but they are not very useful for remote collection of information, work in "field" conditions or in the absence of an expert at the research site. In addition, diagnostic systems

often have a narrowly focused principle without the possibility of integrating new testing tools and the same specialized scenario for creating an expert conclusion.

For professional selection, it becomes necessary to form a professional profile of a person, based on its psychological and psychophysical indicators. The definition of such a profile is possible based on the objective requirements for a particular profession, as well as the requirements of the employer (including non-standard ones). Therefore, to form a profile, a variety of psychodiagnostic techniques can be used, the purpose of which is to determine the specific, both qualitative and quantitative characteristics of a person. This approach presupposes considering the profiles of the subjects as classes or collections of sets that have given common features. Taking into account the variability of the requirements for the profile, the obtained human indicators, the introduction of new diagnostic methods and subjective expert assessment, it is assumed that there is a problem of fuzzy classes. Therefore, it becomes necessary to determine the belonging of the object (subject) to a certain class and the optimal solution to this problem was to use the theory of fuzzy sets using membership functions.

Therefore, the problem of developing conceptually and functionally new psychodiagnostic information and measuring tools for remote sensing is relevant.

Speaking about the development of an information processing system for psychological and psychophysical diagnostics, it is necessary to take into account its multidisciplinary nature and use modern information, software and electronic products and methods [6, 7].

2. Literature review and problem statement

In the works considered below, the results of research and development of hardware and software implementation of diagnostic tools are presented. Such testing tools are technologically diverse and make it possible to implement standard widely used psychodiagnostic techniques. These developments combine a number of principles:

- use of the model of consistent purposeful activity;
- modeling of professional or other human activity in an experimental environment;
- use of the model of space-time forecasting;
- use of the systematic approach;
- availability of flexible methodological capabilities of the system, i.e. implementation of a set of techniques.

However, the presented developments in the field of psychodiagnostic equipment have common problems:

- lack of a specific conceptual model as a basis for their implementation;
- presentation of such systems is limited only to the description of the architecture, block diagrams and diagnostic procedures;
- complete absence or partial possibility of remote control of the system;
- obligatory presence of an expert during diagnostics;
- data storage in a local database;
- architecture of the means does not imply the use of a local network for the transmission and storage of data (or ad hoc uses wired access to the network).

Taking into account the described general problems of existing tools, the analysis of developments will be aimed at considering their structure, architectural solutions and functionality.

The work [8] presents the results of studies of a device for training the adaptive mechanisms of a personality to stressful situations. It has been shown that a device designed to study the body's response to the uncomfortable effect of stimuli is quite well suited for training an adequate patient's response under stress in the absence of an expert. The structure of the device assumes the presence of modules, interacting through standard interfaces, providing stimuli, sensory electrodes and biosignal amplifiers, analysis and control units. A significant drawback of the device under consideration is its use only in stationary conditions.

The results of research and development of the hardware-software psychodiagnostic complex "Multipsychometer", as well as other complexes of this family, [9] are aimed at assessing psychophysiological indicators and professionally important qualities. The functionality of the complex consists in the implementation of test tasks using a control personal computer and executive units connected to it by standard interfaces. Compilation of a multivariate assessment of the subject's actions during the test is due to, albeit a wide, but limited number of standard techniques. Comparison of the obtained

indicators during testing with the average or "optimal" parameters is carried out in a visual graphical and tabular form. A good option of the complex is the possibility of a network version of its execution. However, the full functioning of the complex is possible only with the obligatory presence and participation of an expert, and the blocks of peripheral devices and psychomotor tests are adapted only for a specific target group of subjects.

In work [10], which is devoted to the creation of an automated system for testing, teaching and training its professional skills, solutions are proposed that partially eliminate the indicated disadvantages.

In the architecture of the system, the network principles of organization and adaptation for work with groups of subjects of different professional orientations are laid. The architecture of the system involves the introduction of blocks for remote operation into its structure. This possibility can be implemented on stationary computers that have the appropriate functional testing devices. However, the system refers more to teaching and monitoring educational devices for universities than complexes for studying the psychophysiological parameters of a person.

Research on the development of a psychocorrection system [11], presents the structure of the system as a network of personal computers of subjects and blocks. The system lacks the function of reliable remote operation, and its architecture does not imply its addition of blocks or elements for mobile psychological diagnostics.

The work [12] describes a diagnostic research complex for professional selection of personnel. The complex allows to register psychophysiological parameters, personal characteristics of a person and determine the degree of manifestation of emotional stress. For processing and analysis of measurements, modern software and methods of mathematical statistics are used. The information received is stored in the database. The disadvantages of the complex are the ability to transmit data only over short distances, the impossibility of storing data on a remote server. In this complex, there is no option for collective access to measurement results in real time from geographically dispersed locations. This function of simultaneous observation of the course of the experiment would improve the capabilities of the system in modern realities and would make it possible to involve different experts in the analysis of data simultaneously.

It is also possible to single out the type of psychodiagnostic systems, the functions of which have the ability to transmit data over short distances by radio or infrared data exchange. An example can be a complex for psychophysiological testing "PSYCHOPHYSIOLOGIST-N" [13]. The complex consists of a testing unit and an instructor's workplace, which are connected by an infrared data exchange channel. The IR channel is used to update the firmware of testing devices and receive experimental data. This complex only partially solves the problem of remote presentation of test influences and reception of response signals.

The architecture of an automated information system for the study of human cognitive parameters, described in [14], contains a large number of progressive solutions. It is possible to note such solutions as integrated software modules for scenario modeling and automated analysis of test results, hardware and software units for presenting test tasks and exchanging information on the results of the research. The system has wide functionality and a wide range of psychodiagnostic techniques. However, it does not address the issues related to the complex and volumetric representation of test influences, the answers to which could provide the researcher

with more informative data. Also, this system lacks the function of a remote mode of operation and the problem of synthesis of mobile systems for the operational diagnosis of a person's condition under real and stressful loads has not been studied.

One of the ways to overcome these shortcomings can be the use of the technology of modern wireless infocommunication networks, autonomous sensors and stimulating devices in the development of the architecture of the psychodiagnostic system and its implementation. These devices can be designed on the principles of the Internet of faith.

Thus, the performed analysis gives grounds to assert that it is expedient to design and implement an information processing psychodiagnostic system based on new principles.

The new principles are:

- the principle of remote network information interaction between system objects;
- principle of integrating new (non-standard) diagnostic tools along with standard ones;
- principle of using wireless data transmission technologies: WiFi and GPRS;
- building a new type of profile of the subject - no rigid interpretation of the results;
- no influence of the subjective factor of the expert;
- use of standard and newly created scales.

An open architecture, structural and schematic diagrams of such a fundamentally new system should be implemented on a modern element base, use cloud services, intelligent sensors and actuators based on microcontroller technology.

3. The aim and objectives of research

The aim of research is to design and implement an information processing system using technologies and methods of remote psychological and psychophysical diagnostics of a person. This will make it possible to obtain a psychodiagnostic system of a new generation, which, unlike existing systems, in real time, remotely and without the direct presence of an expert:

- manage the information processing system;
- carry out the diagnostic procedure, in particular in the "field conditions";
- use new hardware, including 3D visual diagnostics;
- securely store data on a cloud server;
- free access of an expert to data using a mobile application and wireless data transmission technologies.

To achieve the aim, the following objectives are set:

- to apply methods of decomposition and identification of classes when forming the structure of an information processing system for remote psychological and psychophysical diagnostics of a person;
- to create a method for diagnosing the psychological or psychophysical state of the subject.

4. Materials and methods of research

To develop the architecture and structural diagram of the information processing psychodiagnostic system, the recommendations of ITU-T Y.2060 and the project of the European integration project IoT-A (Internet of Things – Architecture) [15], describing the IoT reference models, were used. According to these requirements, an information processing system, which is essentially a project of the Internet of Things, should include the following levels:

- application layer;
- level of support for applications and services (both general and additional support for services);
- network layer, implying network and transport capabilities;
- device level (with capabilities of both devices and gateways).

All components, types of their interconnection and areas of application of the information processing system are the corresponding elements of the indicated levels of the IoT model.

When developing the structure of the system, system analysis, methods of decomposition and separation of classes were applied using UML diagrams – an information processing system is considered as a complex complex of interrelated elements, their properties and processes. Moreover, the system possesses properties that none of its elements possesses.

The principles of modular construction are used to form subsystems (blocks) of the information processing system, based on the purpose of the study. Based on the principle of hierarchy, a hierarchy of elements of the blocks of the system being developed was formed, which helps to implement the idea of centralized control. The development principle used in the development of a system model implies the following capabilities: development, improvement of the system, its ability to accumulate information, the ability to integrate new elements that are compatible with existing ones.

Methods of mathematical modeling and mathematical statistics were used to create an algorithm for the formation of an assessment of the impact of the load on the psychological and psychophysical state of a person. The principle of uncertainty and methods of fuzzy logic in the case of indistinctness of classes (determination of the membership function) are used to determine scenarios for the formation of a psychological (psychophysical) profile of a person.

Elements of the theory of automatic control, principles of building information processing systems, elements of basic hardware and software allow to determine the principles of interconnection of system elements, their compatibility with each other and data transmission thanks to them.

The methods of psychological, psychophysiological and psychophysical diagnostics used in the development of the system allow both the implementation of standard diagnostic techniques and form the basis for the creation of new techniques implemented on devices for volumetric data presentation.

The design and implementation of the proposed information processing system is based on the use of the following products: STM32Cube (EC), ESP Easy (China), Microsoft Office 2007 database (USA), Thingspeak server, Wi-Fi and GPRS technologies.

A number of requirements for the information processing system have been formed:

- presence of blocks (classes) corresponding to the main functions of the system;
- use of hardware and software that functionally meet the requirements of the levels of the IoT project model;
- required level of protection and safety of information systems in the event of a failure or failure;
- ability to integrate additional elements of the system;
- reservation of important information resources of the system;
- use of software for processing and visualization of the results;
- presence of scenarios for the formation of the subject's profile.

5. The results of the application of design methods in the development of an information processing psychodiagnostic system

5.1. Application of the method of decomposition and identification of classes in the formation of the structure of the information processing system for remote psychological and psychophysical diagnostics of a person

The decomposition method is used in the work to compare the object of analysis, that is, the developed information processing psychodiagnostic system with a certain model, in this case with the model of the Internet of Things project. A feature of this method is the selection in the object (information processing system) of elements that correspond to the reference model of the IoT project.

The method of representing the structure of the system in the form of a class diagram is used to determine among the elements of the system being developed a set of classes, interfaces and their connections.

The proposed system structure is shown in Fig. 1. It is a single complex consisting of a number of interacting subsystems that perform specific tasks for them [17].

Each subsystem is a control unit, a testing unit, a data receiving and transmitting unit, a data processing and storage unit and has components that interact with each other and with components of other units.

Control unit. The developed control unit is intended for use by an expert in order to register subjects, conduct a testing procedure, view the results obtained and form an expert assessment, as well as an engineer to control the testing procedure. The components of the control unit shown in Fig. 2 in the form of a class diagram are the PC, the mobile application and its interface.

Thanks to the mobile application (Fig. 2), the expert uses the Thingspeak cloud server to manage diagnostic tools and a database to view the results obtained [18].

The components of the unit for testing, receiving and transmitting data and their interaction are shown in Fig. 3. The leading control component of the unit is the STM32F4 microcontroller (China) on the STM32F4Discovery debug board (China) [19–21]. The microcontroller communicates with the WiFi module ESP8266 (China) [22–25] and the GSM module SIM800L (China) [26, 27] using AT commands. The use of two data transmission modules is due to the situation of the absence of a WiFi network, which is possible in the field. In this case, packet data transmission occurs using the SIM800L module to the base stations of mobile communication and, accordingly, through the gateway to the global network.

Information processing system testing unit. The unit consists of the following components [16]:

- panels for the presentation of two-dimensional light, sound, tactile and combined signals;
- devices for three-dimensional representation of signals such as LED cube or LED ball;
- keyboard and microphone for recording responses;
- necessary microelectronic and software.

The use of the ESP8266 module, router and TCP/IP protocol is intended for data transfer to the Thingspeak cloud server DBMS [28–31] using MQTT.

The hardware and software components of the system for presenting test signals and receiving response signals are based on microcontroller technology with radio frequency transceivers for data exchange.

Devices for presenting light signals. Matrices of multi-color LEDs are used to create devices for two-dimensional and volumetric representation of light signals. Working 3D layouts of a LED cube with the size of 8x8x8 LEDs and LED ball were developed. The presentation device for volumetric stimuli is shown in Fig. 4. The required order of switching on the LEDs is set by the microcontroller according to one of the stimulus presentation programs, which is determined by the expert through the control unit.

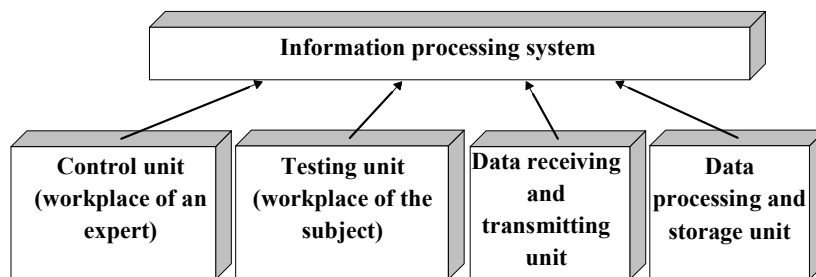

Fig. 1. Information processing psychodiagnostic system

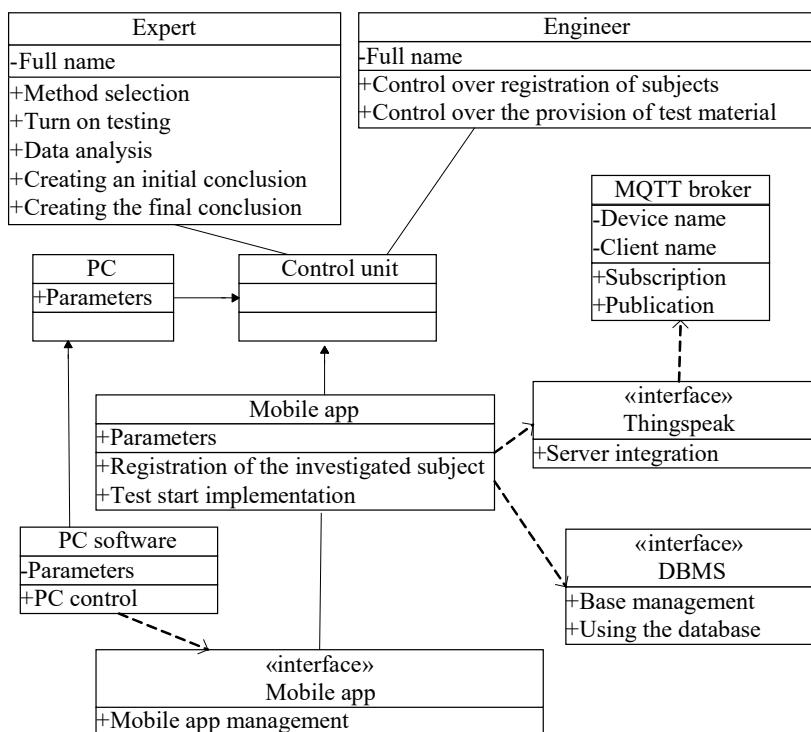

Fig. 2. Class diagram of the control unit

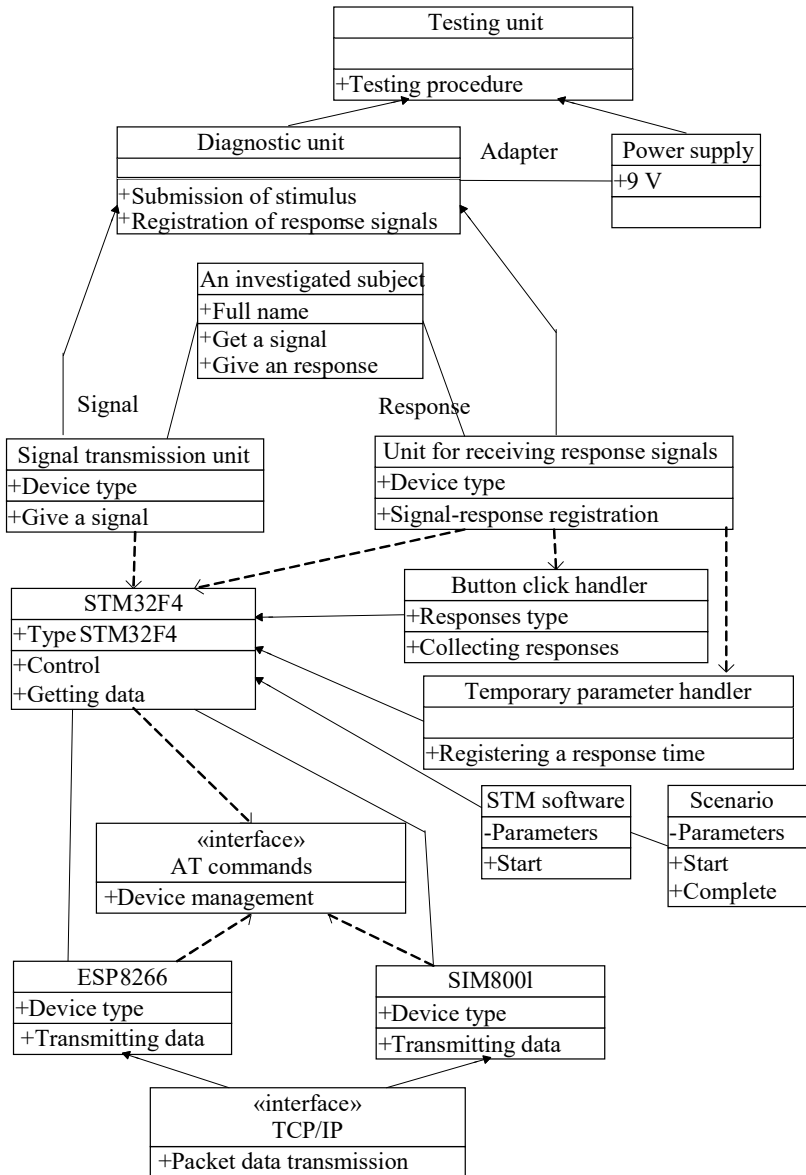

Fig. 3. Class diagram of the testing unit and the data processing and transmission unit

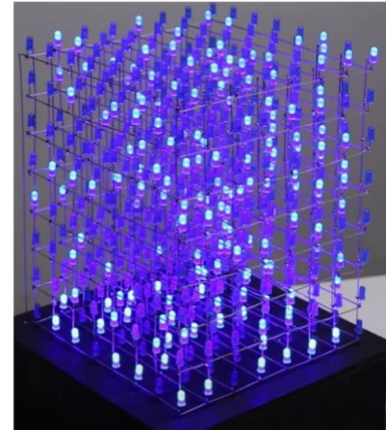

Fig. 4. Layout of devices for presenting volumetric stimuli – LED cube of 8x8x8 LEDs

Fig. 5 shows LED panels for presenting linear and two-dimensional stimuli. The panels use a matrix of three-color addressable digital RGB LEDs with built-in WS2812B controllers on a flexible substrate [32].

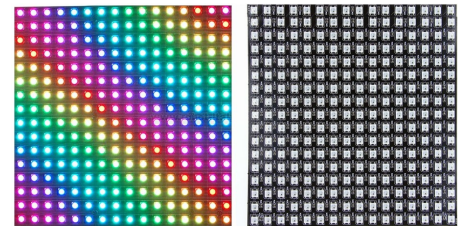

Fig. 5. Panels of WS2812B addressable RGB LEDs

Fig. 6 shows a variant of connecting a one-dimensional LED strip based on three-color addressable digital RGB LEDs WS2812B to an ESP8266 microcontroller with a Wi-Fi interface.

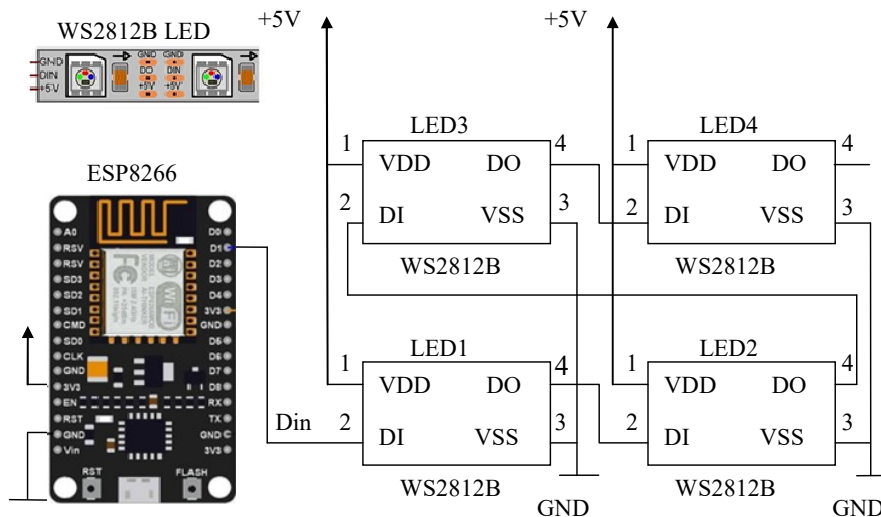

Fig. 6. Scheme of connecting addressable LEDs to the ESP8266 microcontroller with Wi-Fi interface

Depending on the aim of research and the target audience, it is possible to implement devices for representing stimuli in the form of other light figures, including those with a changeable shape during the experiment.

The panel for registering responses is a multi-colored keyboard with dynamic interrogation of pressed keys and their combinations. A microphone is provided for recording sound responses, and a standard IT Web camera for identifying the subject.

5.2. Method of monitoring the psychological and psychophysical state of the subject

A method for monitoring the psychological and psychophysical state of the subject has been developed, which includes 3 stages: formation of a data block (Fig. 7), formation of a primary expert assessment and formation of a final expert assessment (Fig. 8).

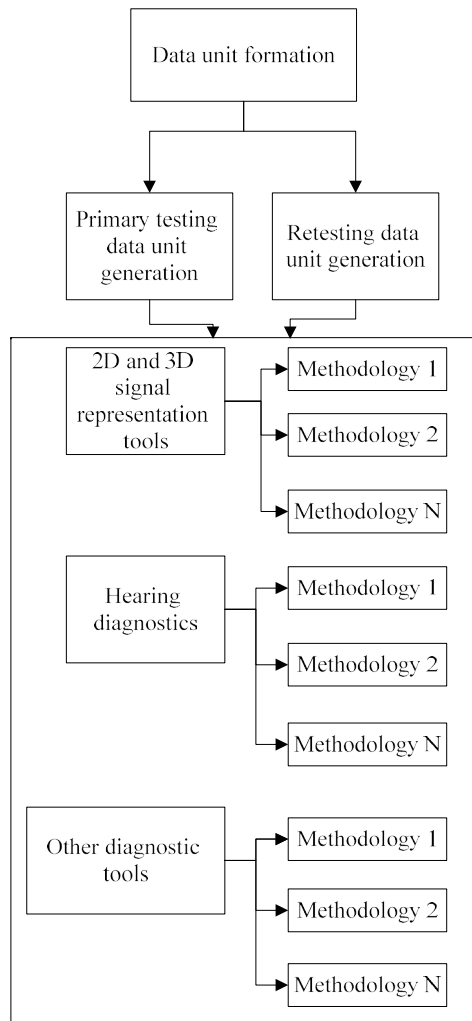

Fig. 7. Method of monitoring the psychological and psychophysical state of the subject: the formation of a data unit

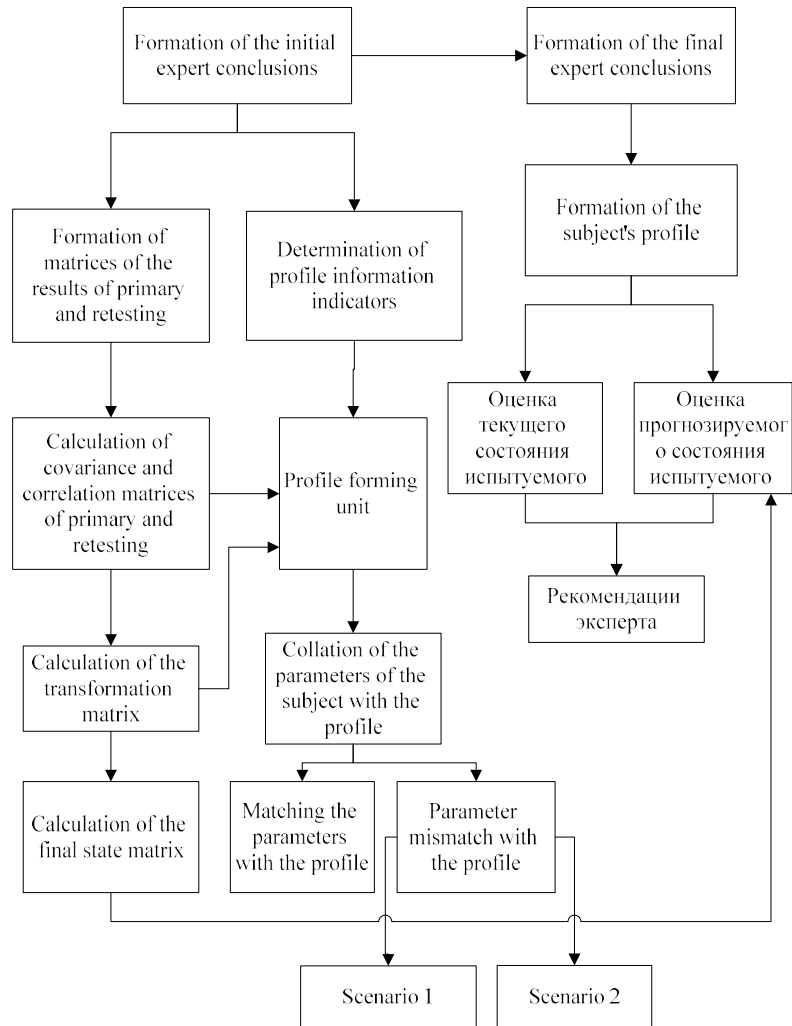

Fig. 8. Method of monitoring the psychological and psychophysical state of the subject: formation of the primary and final expert assessment

5.2.1. Assessment of the influence of the load on the psychological and psychophysical state of a person

For the processing of informative indicators of a person, a method for predicting the effect of different types of visual load on the functional state of the subject was adapted [33]. This method, in fact, is a universal method for assessing the effect of any load on a person's condition.

Analysis of existing studies of the effect of load on the functional state of a person showed the following results. So, when studying the effect of visual load, it was revealed that the load (both adapted to the parameters of the subjects, and not adapted) has 3 types of the nature of changes in the indicators of the functional state. It was found that the distribution of indicators into groups depending on the frequency of occurrence of the nature of the change: growth of indicators – from 44 ±7.9 % to 52±8.0 %, decrease - from 16±5.9 % to 35±7.4 %, unchanged – 19±0.3 % to 19±6.3 %.

In works on the study of the effect of noise on a person's condition, it is determined that a noise level of 20-30 decibels is safe for a person, but higher noise levels have an impact on the human mental sphere. All types of intellectual activity are subject to this influence. An adverse effect is expressed in the

appearance of a feeling of confusion, anxiety, fright, fear, and even a feeling of weakness.

The developed information processing system is the basis for using both existing standard diagnostic methods and integrating new, more modern and more informative methods into its composition. For example, methods that use devices for volumetric presentation of signals and complex stimulation of visual, auditory, tactile and other types of stress. Therefore, the subject's profile includes the presence of blocks corresponding to the types of loads that are determined by the goals of a particular study.

The method consists in determining the transformation matrix M_l using the matrices of the initial X and final Y indicators of the studied state. The matrices used contain the values of the individual and group indicators of the subjects.

Initially, it is assumed that the matrix Y is defined as the result of a linear transformation of the matrix X :

$$Y = M_l \cdot X, \quad y_i = M_l \cdot x_i, i \in 1, l. \quad (1)$$

Using the correlation matrices of the initial F_x and final F_y indicators or their maximum likelihood estimates and the corresponding roots of these matrices A and B :

$$F_x = X \cdot X^T = A \cdot A^T, \quad F_y = Y \cdot Y^T = B \cdot B^T, \quad (2)$$

can be represented by the matrix of final indicators in the form

$$Y = M_l \cdot A = B. \quad (3)$$

Following from this, the desired transformation matrix will be represented as the ratio of the roots of the matrices:

$$M_l = B \cdot A^{-1}. \quad (4)$$

Accordingly, the required transformation matrices, depending on the type of load, will have the form:

$$M_{vis} = B_{vis} \cdot A_{vis}^{-1}, \quad M_{aud} = B_{aud} \cdot A_{aud}^{-1}, \dots, \quad M_{oth} = B_{oth} \cdot A_{oth}^{-1}. \quad (5)$$

This method of assessment makes it possible to predict the final state of the subject and, accordingly, to predict and dose workloads.

5.2.2. Description of scenarios for correlating the parameters of the subject with a specific profile in the case of indistinctness of classes

It is necessary to take into account the fact that the creation of a test subject's profile can be based either on a group assessment of professionals and an expert, or on the subjective assessment of an expert only. Therefore, the algorithm for applying the operations of the theory of fuzzy sets to determine the membership function can have several scenarios.

Scenario 1 implies the use of a number of experts to determine the subject's profile, and assumes that the algorithm for solving this problem will be as follows [34]:

1. Determination of the parameters necessary for the performance of the relevant activity and for correlation with a certain type (position, profession, etc.).

2. Determination of quantitative indicators of these parameters in two groups: a group of diagnosed subjects and a group of profile representatives.

3. Data normalization – the quantitative results of the parameters of the representatives of each group must be presented as a numerical value of the level of formation of the diagnosed parameters of each subject x_i , while x_i can take values from 0 to 1.

4. Ranking of parameters by experts depending on their significance, while the degree of significance ($\mu(x_i)$) is the arithmetic mean of the degrees of significance proposed by the experts.

5. Determination of the numerical values of the level of conformity of the available parameters in the group of subjects (I) and representatives of the profile (R):

$$I = \frac{\sum_{i=1}^n (x_i \mu(x_i))}{n}, \quad (6)$$

$$R = \frac{\sum_{i=1}^n (y_i \mu(y_i))}{n}, \quad (7)$$

where I, R – the numerical values of the level in the corresponding groups, x_i and y_i are the value of the i -th parameter in the groups of subjects and representatives of the profile, $\mu(x_i)$ and $\mu(y_i)$ are the significance of the corresponding parameter, n is the number of parameters.

6. To determine the levels of conformity of the parameters of the tested and representatives to the given profiles in percentage terms, the boundaries of this conformity are determined. This is due to the assumption that the representative of the profile can have the maximum and minimum quantitative values of the parameters, which means that the level Y has the limits of R_{max} and R_{min} .

The numerical indicators of the level of compliance of the parameters with the profile will look as follows

$$Y_I = \frac{I \cdot 100\%}{R_{max}}, \quad (8)$$

$$Y_R = \frac{R \cdot 100\%}{R_{max}}, \quad (9)$$

where Y_I and Y_R are the values of the levels of compliance of a person with the profile in the studied groups in percentage terms, where I, R are the numerical values of the level in the groups, R_{max} is the maximum value of the level of compliance.

7. Determination of scale levels with a percentage for a more simplified presentation of the results.

Scenario 2 implies the following functionality: the ability to work on a human profile of only one expert, operations on parameters that are not numerical in nature.

Scenario 2 involves the construction of a membership function using a matrix, the elements of which are expert paired comparisons of parameters [35].

Let the matrix be $M = \|m_{ip}\|$, where $i, p=1..n$, where n is the number of comparison points of the values of functions, that is, how many times the function of belonging of the subject $\mu_A(X_i)$ to the fuzzy set A is greater than the function of belonging of the subject $\mu_A(Y_p)$ to the fuzzy set A .

Then the elements of the matrix are normalized and take the form

$$c_1 = \frac{1}{m_{i1}}, \quad c_2 = \frac{1}{m_{i2}}, \quad \dots, \quad c_p = \frac{1}{m_{ip}}. \quad (10)$$

After that, the sum of the elements of the matrix C and its weight w are determined:

$$C = \sum_{i=1}^n c_i, \quad w = \frac{1}{C}. \quad (11)$$

Next, the matrix M^* is calculated, the elements of which are the degrees of membership of the parameters:

$$M^* = [c_1 \cdot w, \dots, c_n \cdot w]. \quad (12)$$

In the case of obtaining a subnormal fuzzy set, it is necessary to normalize it and determine the membership function, which, in fact, will be an indicator of the confidence in the correlation of an object with a class.

6. Discussion of the results of design and implementation of the information processing system

The use of methods of decomposition and allocation of blocks (classes) based on functional requirements made it possible to form the structure of an information processing psychodiagnostic system. Considering that the information processing system is based on the principles of the Internet of Things, then the following system elements correspond to each level:

- level of applications – the branches “psychology”, “labor market”;
- application and service support level – Thingspeak cloud server, MQTT protocol, DBMS;
- network layer – data transmission technologies GPRS and WiFi, LTE, Ethernet, STM32F4 microcontroller, SIM800L module, ESP8266 module, router;
- device level – 2D and 3D stimulus presentation devices and other diagnostic hardware, keyboard.

Thanks to the above methods, the system was presented in the form of 4 interacting blocks (Fig. 1), each of which is responsible for performing a number of system functions:

1. Control unit (PC (smartphone), mobile app, mobile app interface):
 - registration of subjects by an expert;
 - selection of the tested material by an expert;
 - remote testing procedure;
 - work with the obtained data of the subjects;
 - formation of the primary and final expert assessment (profile of the subject).
2. Testing unit (hardware diagnostics, keyboard):
 - submission of incentives;
 - registration of answers and reactions of the subject.
3. Data receiving and transmitting unit:
 - management of diagnostic tools;
 - data processing and transmission to modules, thanks to AT commands;
 - implementation of packet data transmission using TCP/IP.
4. Data processing and storage unit:
 - data storage;
 - control and monitoring of the states of the elements of the block for receiving and transmitting data using a cloud server;
 - data processing and visualization.

The proposed structure of the information processing system assumes the following principles of its operation. The expert forms a request for the diagnostic procedure (together with the customer), selects the material to be tested, sends a

command to turn on and off the diagnostic hardware, analyzes the test results obtained, and forms the test subject’s profile. The engineer, in turn, monitors the correct operation of the equipment, recording data to the cloud server and database.

Changing the operating modes of the hardware part of the information processing system is carried out thanks to the mobile application. During testing, the test material is submitted according to the scenario, the execution of which is guaranteed by the software of the STM32F4 microcontroller. The data is processed by the handlers for pressing the buttons and the time parameter and, thanks to AT commands and TCP/IP, data is exchanged between the elements “STM32F4 microcontroller” – “GPRS and WiFi modules” – “router”. In the absence of any communication, data is accumulated in the buffer memory of the remote device. Further, thanks to the MQTT protocol, data is exchanged and recorded in the channels of the Thingspeak cloud server.

The ThingSpeak platform from MathWorks (USA) has an integrated mathematical package MATLAB (USA) [36]. The use of this popular package allows for high-quality mathematical data processing, the formation of the subject’s profile and the construction of graphs for the visual presentation of psychophysical measurement data. Working with the database is carried out using a mobile application and a DBMS interface.

Thanks to the proposed conceptual solutions and the use of modern hardware and software, the functionality of the system makes it possible to reliably conduct psychodiagnostics, both in stationary conditions and to work with remote patients. At the same time, subjects and experts can be in different parts of the world and conduct experiments at any time. Remote presentation of stimuli and interrogation of response sensors is carried out through a mobile application.

To enhance the diagnostic characteristics, the system includes devices for three-dimensional (3D) presentation of stimuli along with standard two-dimensional or linear ones. 3D means of visual and sound psychodiagnostics allow conducting research that is closest to natural conditions.

The use of cloud technologies in the proposed system is justified by convenient network access “for everyone, everywhere and from any device connected to the Internet” to a common pool of computing and communication resources. Such technologies provide fundamentally new, cost-effective opportunities for research and education, providing remote use of computing, processing and storage of information, as well as sharing the database among experts.

During the development and research of the system, its following limitations were identified:

- data is written to the Thingspeak cloud server every 15 seconds when using the free version, with the possibility of reducing the cycle time to 1 second when using the cloud on a commercial basis;
- only WiFi or GPRS connections are used for remote data exchange.

At the moment, the created monitoring method is of a conceptual theoretical nature, but its quick practical implementation is planned.

The proposed information processing system is considered as a project of the Internet of Things. Therefore, it also carries all the risks of the IoT. The main ones are data leakage, interception and substitution of transmitted data and unauthorized access, the probability of which is determined by the degree of system protection at the software and hardware levels. It is possible to reduce the likelihood of these threats by using built-in means of device authentication and encryption of transmitted

data. The probability of interception and spoofing of transmitted data is low, since encryption is already built into many IoT protocols. The use, for example, of the LoRa WAN protocol, which uses double data encryption using the AES-128 algorithm, makes it almost impossible to intercept and decrypt data.

The use of a remote mode of operation in real time is difficult with poor Internet access and no mobile communication. Over time, this disadvantage will become insignificant due to the rapid growth of coverage of territories with branched mobile networks.

Devices for signal presentation have been developed, taking into account the peculiarities of two-dimensional and volumetric perception. They are based on 32-bit microcontrollers and multicolor addressable digital RGB LEDs for visual test loads. Tactile and volumetric sound signals of influence and their combinations are also formed under the control of microcontrollers. All signals cover the range of sensitivity of the human sensory organs. 2D viewers implement standard diagnostic techniques. The devices for three-dimensional signal presentation are presented in two configurations – a 3D cube and a 3D ball and are designed to implement new adapted testing methods.

The methods used to assess the influence of various types of load on the psychophysical and psychological state of the subject can significantly expand the area of diagnostic application of the information processing system. The described scenarios of correlating the parameters of the subject's reaction with a specific profile in the case of indistinctness of the classes make it possible to use them both with quantitative and qualitative characteristics of the studied parameters, which significantly expand the range of psychodiagnostic techniques used.

In the future, the development of this study may consist in creating a conceptual model of the system and its structure in the direction of developing hardware and software modules of criterion-oriented tests to eliminate the low content validity of statistical norms of psychodiagnostics. It is necessary to develop new algorithms for identifying the degree of preparedness of each subject to perform a certain criterion task based on new principles of psychodiagnostic testing. It is also important to search for new non-standard instrumental solutions for psychodiagnostics, as close as possible to the real conditions of a person's performance of its professional duties. To expand the functionality of the

information processing system, it may be possible to create the basic software “electronic expert” for emergency remote consultation in critical situations. This approach can become the basis for creating a series of psychodiagnostic equipment of a fundamentally new generation.

7. Conclusions

1. The structure of the information processing psychodiagnostic system, in contrast to the structures of the existing hardware for human diagnostics, is based on the principles of the Internet of Things model. The description of the components and their interaction within the framework of the structure of the psychodiagnostic system is carried out. The developed structure of the information processing psychodiagnostic system and its blocks fully corresponds to the formed principles provided, on the one hand, by the reference models of the Internet of Things, and, on the other hand, by the procedure of psychological diagnostics.

2. Created an algorithm for monitoring the human condition, which consists of several stages. An algorithm for processing informative indicators for the formation of an assessment of the influence of load (visual, auditory, psychomotor and other types) on the psychological and psychophysical state of a person is described. The result of this algorithm is transformation matrices, which are, in fact, the degree of influence of the visual, auditory or other type of psychophysical load presented by the information processing system. The specified algorithm is applicable to various types of loads provided by the information processing system, and allows predicting the final state of the subject and adjusting its activity. Two scenarios are proposed for correlating the parameters of the subject with a specific profile in the case of unclear classes, i.e., the impossibility of determining a specific class of characteristics of a person according to the requirements. The difference in scenarios is due to group and individual expert assessment. The result of these scenarios is the determination of the membership function of the subject's profile to one of the profile classes. Such a solution to the problem allows to apply algorithms and determine the profile of a person, using both quantitative and qualitative indicators of human parameters.

References

1. Balin, V. D., Gayda, V. K., Gerbachevskiy, V. K. et. al. (2003). *Praktikum po obschey, eksperimental'noy i prikladnoy psihologii*. Sankt-Peterburg: Piter, 560.
2. Kalnysh, V. V., Yena, A. I. (2001). Pryntsyпы profesiynoho psykhoziolohichnoho vidboru. *Hihiena pratsi*, 32, 131–144.
3. Hussein, A. H. (2019). Internet of Things (IOT): Research Challenges and Future Applications. *International Journal of Advanced Computer Science and Applications*, 10 (6). doi: <https://doi.org/10.14569/ijacsa.2019.0100611>
4. Wortmann, F., Flüchter, K. (2015). Internet of Things. *Business & Information Systems Engineering*, 57 (3), 221–224. doi: <https://doi.org/10.1007/s12599-015-0383-3>
5. Remesh, A., Muralidharan, D., Raj, N., Gopika, J., Binu, P. K. (2020). Intrusion Detection System for IoT Devices. 2020 International Conference on Electronics and Sustainable Communication Systems (ICESC). doi: <https://doi.org/10.1109/icesc48915.2020.9155999>
6. Liu, H., Ning, H., Mu, Q., Zheng, Y., Zeng, J., Yang, L. T. et. al. (2019). A review of the smart world. *Future Generation Computer Systems*, 96, 678–691. doi: <https://doi.org/10.1016/j.future.2017.09.010>
7. Podder, A. K., Bukhari, A. A., Islam, S., Mia, S., Mohammed, M. A., Kumar, N. M. et. al. (2021). IoT based smart agrotech system for verification of Urban farming parameters. *Microprocessors and Microsystems*, 82, 104025. doi: <https://doi.org/10.1016/j.micpro.2021.104025>
8. Rozhkovskiy, H. V. (2013). Pat. No. 90435 UA. Systema dlia psikhokorektsiyi. No. u201315401; declared: 30.12.2013; published: 26.05.2014, Bul. No. 10. Available at: <https://uapatents.com/12-90435-sistema-dlya-psikhokorekci.html>

9. Apparatno-programmniy psihodiagnosticheskiy kompleks MULTIPSIHOMETR. Nauchno-proizvodstvenniy tsentr «DIP». Available at: <http://www.multipsihometr.ru/izdel/mpm/>
10. Karpenko, M. P., Karpenko, D. S., Burdakov, M. V. (2000). Pat. No. 2163731 RU. Abstract of invention. No. 2000120464/28; declared: 04.08.2000; published: 27.02.2001. Available at: <https://patentimages.storage.googleapis.com/2c/21/35/421ede05b9527a/RU2163731C1.pdf>
11. Rozhkovskiy, H. V. (2013). Pat. No. 109206 UA. Systema psikhokorektsiyi. No. a201315398; declared: 30.12.2013; published: 27.07.2015, Bul. No. 14. Available at: <https://uapatents.com/11-109206-sistema-psikhokorekci.html>
12. Malhazov, A. R., Harchenko, V. P. (2008). Diagnosticheskiy issledovatel'skiy kompleks dlya provedeniya professional'nogo otbora kadrov IK 01.0. Vynakhidnyk i ratsionalizator, 5 (78), 6–11. Available at: <https://vir.uan.ua/archives/2008/2008-5s.pdf>
13. Ustroystvo psihofiziologicheskogo testirovaniya UPFT-1/30 «Psihofiziolog». Meditsinskoe oborudovanie dlya diagnostiki, nefrofiziologii i reabilitatsii. Available at: <http://medicom-mtd.com/htm/Products/psychophisiolog.html>
14. Zlepko, S. M., Pavlov, S. V., Tymchyk, S. V., Navrotska, K. S. (2014). Pat. No. 99286 UA. Avtomatizovana informatsiyna systema dlia doslidzhennia kohnityvnykh funktsiy liudyny. No. u201413764; declared: 22.12.2014; published: 25.05.2015, Bul. No. 10. Available at: <https://uapatents.com/5-99286-avtomatizovana-informacijna-sistema-dlya-doslidzhennya-kognitivnykh-funkcij-lyudini.html>
15. Recommendation Y.4000/Y.2060 (06/12). Available at: <https://www.itu.int/rec/T-REC-Y.2060-201206-I>
16. Varlamova, N., Lazurik, V., Styervoyedov, N. (2019). Model and hardware-software implementation of information processing system for psychophysical and psychophysiological researches. Bulletin of V.N. Karazin Kharkiv National University, Series «Mathematical Modeling, Information Technology. Automated Control Systems», 44, 16–22. doi: <https://doi.org/10.26565/2304-6201-2019-44-02>
17. Lazurik, V. T., Styervoyedov, M. G., Varlamova, N. V. (2020). Information Processing System for Psychophysical Research with Two- and Three-dimensional Presentation of Test Signals. Control Systems and Computers, 4 (288), 66–75. doi: <https://doi.org/10.15407/csc.2020.04.066>
18. Muthmainnah binti Mohd Noor, N., Afiq Afifi bin Mohd Zafie, M. (2021). Smart Gate Using Android Applications. Journal of Physics: Conference Series, 1755 (1), 012003. doi: <https://doi.org/10.1088/1742-6596/1755/1/012003>
19. STM32 32-bit ARM Cortex MCUs. Tools & Software. Available at: <https://www.st.com/en/microcontrollers/stm32-32-bit-arm-cortex-mcus.html>
20. Bousselmi, S., Saoud, S., Cherif, A. (2020). Real-Time Implementation of an Optimized Speech Compression System in STM32F4 Discovery Board. Proceedings of the 8th International Conference on Sciences of Electronics, Technologies of Information and Telecommunications (SETIT'18), 37–48. doi: https://doi.org/10.1007/978-3-030-21009-0_4
21. Marciniak, T., Podbucki, K., Suder, J., Dąbrowski, A. (2020). Analysis of Digital Filtering with the Use of STM32 Family Microcontrollers. Advanced, Contemporary Control, 287–295. doi: https://doi.org/10.1007/978-3-030-50936-1_25
22. Singh, K., Kumar, R. (2021). Design of a Low-Cost Sensor-Based IOT System for Smart Irrigation. Applications in Ubiquitous Computing, 59–79. doi: https://doi.org/10.1007/978-3-030-35280-6_4
23. Prayogo, S. S., Mukhlis, Y., Yakti, B. K. (2019). The Use and Performance of MQTT and CoAP as Internet of Things Application Protocol using NodeMCU ESP8266. 2019 Fourth International Conference on Informatics and Computing (ICIC). doi: <https://doi.org/10.1109/icic47613.2019.8985850>
24. Singh, U., Ansari, M. A. (2019). Smart Home Automation System Using Internet of Things. 2019 2nd International Conference on Power Energy, Environment and Intelligent Control (PEEIC). doi: <https://doi.org/10.1109/peeic47157.2019.8976842>
25. Liang, Y., Lu, W., Guo, P., Zhou, Z., Zhang, T. (2018). Remote Wi-Fi Smart Switch Based on Cloud Platform. Proceedings of the International Symposium on Big Data and Artificial Intelligence. doi: <https://doi.org/10.1145/3305275.3305325>
26. Lita, I., Visan, D. A., Mazare, A. G., Ionescu, L. M., Lita, A. I. (2020). Automation Module for Precision Irrigation Systems. 2020 IEEE 26th International Symposium for Design and Technology in Electronic Packaging (SIITME). doi: <https://doi.org/10.1109/siitme50350.2020.9292300>
27. Munawir, Ihsan, A., Mutia, E. (2019). Wi-Fi and GSM Based Motion Detection in Smart Home Security System. IOP Conference Series: Materials Science and Engineering, 536, 012143. doi: <https://doi.org/10.1088/1757-899x/536/1/012143>
28. ThingSpeak. Available at: <https://thingspeak.com/>
29. Viegas, V., Pereira, J. M. D., Girão, P., Postolache, O. (2021). Study of latencies in ThingSpeak. Advances in Science, Technology and Engineering Systems Journal, 6 (1), 342–348. doi: <https://doi.org/10.25046/aj060139>
30. Penchalaiah, N., Nelson Emmanuel, J., Suraj Kamal, S., Lakshmi Narayana, C. V. (2020). IoT Based Smart Farming Using Thingspeak and MATLAB. ICCCE 2020, 1273–1295. doi: https://doi.org/10.1007/978-981-15-7961-5_117
31. Li, M. (2019). Design of Multi-network Data Acquisition System Based on Cloud Platform. 2019 International Conference on Virtual Reality and Intelligent Systems (ICVRIS). doi: <https://doi.org/10.1109/icvr.2019.00033>
32. Nguyen-Ly, T. T., Tran, L., Huynh, T. V. (2019). Low-cost, high-efficiency hardware implementation of smart traffic light system. 2019 International Symposium on Electrical and Electronics Engineering (ISEE). doi: <https://doi.org/10.1109/isee2.2019.8921146>
33. Saikivska, L. (2015). Development and use of information technology for evaluating an operator's visual profile functional state. Technology audit and production reserves, 4 (2 (24)), 45–49. doi: <https://doi.org/10.15587/2312-8372.2015.47914>
34. Chernyavskaya, E. V. (2011). Fuzzy logic to assess schoolchildren professional suitability. Vestnik NGU. Seriya: Pedagogika, 12 (2), 66–71. Available at: <https://nsu.ru/xmlui/bitstream/handle/nsu/3136/06.pdf?sequence=1&isAllowed=y>
35. Burilich, I. N., Uvarova, A. G., Filist, S. A. (2006). Avtomatizirovannaya sistema diagnostiki shizofrenii na osnove nechetkoy logiki prinyatiya resheniy. Vestnik novykh meditsinskih tekhnologiy, 13 (2), 46–49. Available at: <https://cyberleninka.ru/article/n/avtomatizirovannaya-sistema-diagnostiki-shizofrenii-na-osnove-nechetkoy-logiki-prinyatiya-resheniy>
36. D'yakonov, V. P. (2011). MATLAB i SIMULINK dlya radioinzhenеров. Moscow: «DMK-Press», 976.