

Sensors used in rocket and space technology are subject to extreme external influences in terms of temperature, vibration, and shock. Therefore, the choice of the type of sensors is justified precisely by the resistance to such factors, as well as the ability to ensure the temporal and parametric stability of measurements. A new type of sensors – fiber-optic ones – meets these conditions. The basis for the selection and further improvement of such sensors were such requirements as minimum power consumption, high accuracy and stability of measurements, the ability to combine several measurements in one sensor. It is noted that for space infrastructure the factor of the possibility of simultaneous measurement of several parameters with one sensor is one of the important quality indicators. This is due to the possibility of reducing the number of sensors themselves, which reduces the mass and size parameters of space technology. This applies, first of all, to measurements of pressure and temperature, since they, in aggregate, account for at least 40 % of all measurements in space products. The path of choosing the types of methods and sensor designs led to the combination of the amplitude conversion method and optical communication in one sensor. In this case, amplitude modulation of pressure and temperature is carried out by a microelectromechanical unit (module), and the modulated optical signal is transmitted by an optical module. Such a modular composition of the sensor makes it possible to dispense with optical analyzers (interrogators) and carry out further processing based on standard interfaces. A limitation of the proposed methods and designs is the need for microelectromechanical structures that measure certain physical quantities. Such structures for fiber-optic sensors are not mass-produced; therefore, their manufacture can be established at instrument-making enterprises with microelectronic equipment

Keywords: fiber-optic sensor, photodiode, laser light-emitting diode, Bragg grating, combined

UDC 681.2.084

DOI: 10.15587/1729-4061.2021.242995

MULTIFUNCTIONAL FIBER-OPTIC SENSORS FOR SPACE INFRASTRUCTURE

Petr Mikhailov

Doctor of Technical Sciences, Professor, Leading Researcher
Department of Scientific Research
Penza State Technological University
Gagarina/Baydukova str., 11/1a, Penza, Russian Federation, 440039

Zhomart Ualiyev

Corresponding author
PhD, Head of Department
Department of High Mathematics*
E-mail: zh.ualiyev@satbayev.university

Assem Kabdoldina

PhD, Senior Lecturer
Department of Chemical Physics and Material Science
Al-Farabi Kazakh National University
al-Farabi ave., 71, Almaty, Republic of Kazakhstan, 050040

Nurzhit Smailov

PhD, Associate Professor
Department of Electronics, Telecommunications and
Space Technologies*

Askar Khikmetov

PhD, Rector
International Information Technology University
Manas str., 34/1, Almaty, Republic of Kazakhstan, 050040

Feruza Malikova

PhD, Head of Department
Department of Information Technology
Almaty Technological University
Tole bi str., 100, Almaty, Republic of Kazakhstan, 050012

*Satbayev University

Satpaev str., 22a, Almaty, Republic of Kazakhstan, 050013

Received date 01.09.2021

Accepted date 18.10.2021

Published date 29.10.2021

How to Cite: Mikhailov, P., Ualiyev, Z., Kabdoldina, A., Smailov, N., Khikmetov, A., Malikova, F. (2021). Multifunctional fiber-optic sensors for space infrastructure. *Eastern-European Journal of Enterprise Technologies*, 5 (5 (113)), 80–89.

doi: <https://doi.org/10.15587/1729-4061.2021.242995>

1. Introduction

In instrumentation, a new direction in information-measuring systems is rapidly developing: the development and mastering of the production of fiber-optic sensors (FOS). Due to their unique properties of resistance to external destabilizing factors, radiation resistance and complete fire and explosion safety, they are used in many industries and systems. The use of fiber optic sensors in space instrumentation has not yet found wide application. This is due to the fact that traditional instruments and systems in space products are based on analog and digital sensors with standard interfaces. FOS have completely different interfaces, for example, Fiber Channel.

The world manufacturers of FOSs are Siemens (Germany), Backer Hughes (USA), Halliburton (USA), Schlum-

berger (USA) Emerson Electric Co. (USA), and Russian enterprises "Omega", "Optolink", "Intel-Systems". The volume of the FOD sales market for extreme conditions, according to estimates by the American business consulting company Frost & Sullivan (USA), in 2011 amounted to about \$ 1,200 billion and, according to the forecast, by 2020 will grow to \$ 8.5 billion [1].

According to the classification and principle of operation, all FOSs can be divided: into devices with amplitude modulation of the characteristics of the luminous flux (intensity, optical trajectory) and devices with frequency-phase modulation (with Bragg gratings). In the first of them, modulation is carried out from third-party elements: curtains, furniture, consoles, bellows and others. [2]. This design is complex, and the sensors themselves are not highly accurate.

Phase modulation requires specialized technological equipment to form gratings [3].

It should be noted that an indispensable functional element of any measuring system based on wave Bragg gratings (WBG) is an interrogator (Bragg grating interrogator), which is a narrow-band spectrometer, which is the most expensive element of a system with expensive software. The cost of the SI255 interrogator for 4 channels is about 45,000 USD.

For the basic conversion method, the design and method of conversion of pressure and temperature FOSs using the amplitude modulation method were selected. At the same time, the sensor itself is completed from micro-electromechanical systems of a sensitive element that measures a physical quantity and an optomodule that generates and transmits modulated signals of the temperature and deformation channels. This makes it possible to make a multifunctional sensor and reduce their total number, which is very important for space technology.

2. Literature review and problem statement

In [4], an optoelectric system for monitoring the state of civil, aerospace and mechanical structures is presented, which implements the method of dynamic demodulation of spectral shifts in sensors with a Bragg wave grating (WBG). A common approach to polling sensors has been shown to involve transmitting a broadband light source through the sensor and monitoring the spectrum of reflected light from the WBG. In this case, as a demodulator, the center wavelength λ_0 of the reflected light depends on the period and the effective refractive index in the measuring section of the sensor. Any disturbance of these values due to mechanical or thermal deformation leads to a shift in λ_0 , which is controlled by a spectral demodulator based on a photorefractive indium phosphorus crystal.

The disadvantage of this method is its temporal and temperature instability due to the drift of the electrophysical characteristics of the demodulator (photodiode). In addition, the method and design do not allow temperature measurement.

The work [5] describes FOS based on WBG, which are formed in a microstructured fiber with a high degree of birefringence, which increases the sensitivity to deformation. It should be noted that this design is complex and difficult to reproduce.

In [6], the results of the development of numerical models of a cantilever fiber-optic sensor with a tip used in a wind tunnel and its implementation are presented. There, numerical models are compared with experimental results. This design has significant drawbacks due to the low reproducibility of the dry contact elements of the tip.

In addition, a common disadvantage of these FOSs is the absence of a temperature channel and the presence of an interrogator in the system.

In [7], a two-parameter fiber-optic sensor based on WBG is described and demonstrated, cascade connected to the structure of a Fabry-Perot interferometer for simultaneous measurement of gas temperature and pressure. The FOS design is complex and contains a number of devices with poorly controlled electrophysical characteristics (adhesive parts, UV curing, etc.).

The work [8] describes a FOS design based on the interaction of optical radiation with a membrane, in which the

curvature of the rings of optical fibers changes. This design is not very stable in time and depends on temperature.

In [9], the results and methods of stabilizing the parameters of sensors are displayed, which are based on thermal stabilization and fitting. Thermal stabilization and adjustment operations are carried out during assembly and testing of sensors, which increases labor intensity and decreases stability.

The overwhelming majority of well-known scientific and technical publications are devoted to FOSs built on the basis of WBGs using various design and technological methods.

Such technologies can be:

- doping of quartz fibers with various additives;
- presence of inclusions with different optical characteristics than optical fiber;
- areas with laser alloying.

The main disadvantages of these studies and developments are the complexity of the structures and the need for expensive hardware and software. All this allows to assert that it is necessary to develop a universal multichannel FOS for pressure and temperature.

It should be noted the specificity of sensors intended for use in space technology. This is due to the fact that spacecraft are exposed to the electrophysical factors of outer space: electric fields, flows of charged particles, plasma. In addition, during starts, the sensors are exposed to significant overloads in temperature, vibrations and significant levels of electromagnetic interference. Such a set of requirements cannot be met by sensors based on traditional transformation principles: strain-resistive, electromagnetic, piezoelectric. Therefore, recently a new direction in sensor engineering has been developing – fiber-optic sensors. They use coherent optical radiation to receive, convert and transmit information about the measured physical quantity, most often pressure and temperature.

In practice, two directions of FOS construction are used, which differ in the principles of modulation of optical radiation: amplitude and phase-frequency [6]. Examples of the implementation of such FOS designs are given in [7]. FOS designs given in the sources have phase-frequency [6], and in [7] – amplitude methods for converting optical radiation. Neither source allows achieving multifunctionality in terms of measuring several physical quantities.

Let's consider in more detail the positive and negative signs of transformation methods, structures and schemes.

Spectral fiber optic sensors can be used to detect voltage, pressure, temperature, chemical composition, haze, color and other measured values. There are two separate methods of operation for sensors: a sensor with one sensing point at the end of the fiber and a distributed detection method. A sensor with one sensing point at the end of the fiber is the simplest type of fiber optic, which consists of an indicator located at one end of the fiber, a light source and a sensor at the other. Optical radiation passes through the fiber and interacts with the indicator, producing a spectral signal (fluorescence, phosphorescence, absorption). The signal is then fed back, measured by the sensor and linked to the measured variable. In this case, the fiber has a single sensing area at one of its ends and only serves as a light conductor that propagates without scattering from one end of the fiber to the indicator and back.

In a distributed sensing method, all or part of the fiber acts as both a signal conductor and a sensor. In this method, it is possible to use a fiber with a continuous cladding

that is sensitive to the measurement parameter, as well as fibers with several sensitive claddings separated from each other. Regardless of the approach, the probed areas can be examined with light in the fiber, resulting in a multi-point quasi-distributed readout. While a distributed sensor requires one fiber for multiple spatial measurements, a sensor with one sensing point at the end of the fiber requires multiple fibers. Therefore, the advantage of distributed sensing is that multiple spatial measurements can be made with a single device.

The probing areas of a distributed fiber optic can be investigated in two different ways: in the axial direction or in the direction perpendicular to the fiber axis; the latter case (transverse sounding) is considered the predominant mode of operation.

The axial method is widely used in optical fiber optics, in which case light is introduced into one end of the fiber along its axis and interacts with the surrounding cladding, decreasing its intensity. The cladding, in this case, absorbs the scattered light, while the reflected signal (which can be detected at both ends of the fiber) is either absorbed or scattered.

However, this type of axial sensing recording has serious disadvantages. For example, the interaction between the radiation and the sensitive envelope is very weak and requires expensive tools (high power source, expensive detection circuitry and/or very long optical fiber) to detect the resulting signal. In addition, depending on the location, the alignment of a light source such as a fiber-axis laser requires careful processing.

Modern fiber optic sensors allow measuring almost all physical quantities. They can be non-electrical, for example, mechanical: deformation, mass, liquid level, acoustic pressure. Motion parameters can also be measured by FOS: rotation speed, linear movement, acceleration, vibration. Electrical physical quantities include: electric field, electric current, magnetic field. The entire endoscopy technique is based on the use of optical beams [10].

Measuring water turbidity is an important control element in a wide range of activities, from environmental monitoring and filter control to fish farms. The measurement of water turbidity is performed by a specialized fiber-optic water turbidity sensor, which is also called a turbidimeter (turbidity meter).

The method for determining the turbidity of water with a turbidity meter is photometric. When measuring the attenuation of transmitted light, one speaks of the turbidimetric method, and when measuring the light scattering of reflected light, the nephelometric method. Also, turbidity sensors differ in purpose and method of operation (industrial or portable). Such devices include: industrial M1415 (USA), turbidimeter IMP 2A (Russia); HI 93703 (Germany) providing laboratory measurement accuracy in the field. All of them are rather expensive devices with specialized software.

3. The aim and objectives of research

The aim of research is to develop designs and technologies for manufacturing multifunctional pressure and temperature FOSs with characteristics that meet the conditions of space infrastructure. This will make it possible to reduce the number of sensors and expand their functionality.

To achieve the aim, the following objectives were set:

- to analyze the loss of optical radiation in order to improve the measurement accuracy when exposed to external interference;
- to identify and implement physically and technologically compatible methods of converting various physical quantities, carried out by one sensor;
- to propose a technology for the manufacture of FOS sensitive elements.

4. Materials and methods of research

The object of research is the methods of analysis and implementation of multifunctional pressure and temperature FOS with characteristics that meet the conditions of space infrastructure, characterized by high levels of electromagnetic interference and external mechanical influences. In this case, not the connectivity of the information of the pressure and temperature channels is allowed, but the shape and modulation of the optical beam is represented by models of geometric optics.

The research method is the analysis of the processes of transmission of radiation in the optical fiber and their numerical modeling. The basis of mathematical modeling is the equations of geometric and wave optics.

5. Results of the development of fiber-optic pressure and temperature sensors for space infrastructure

5.1. Reduction of information losses in optical channels

The main sources of information losses in optical channels are losses in optical fiber and in the nodes of their connection with electronic conversion units.

In addition, specially formed bending sections of the optical fiber are used in FOS as sensitive elements (Fig. 1) [11].

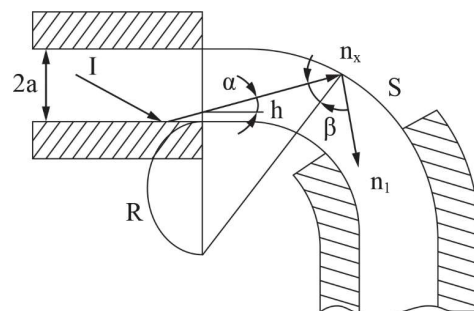

Fig. 1. Fiber optic single bend sensing element [11]

In studies on experimental samples of sensitive elements, bending zones were formed, which increased the deformation activity of the optical fiber (Fig. 2) [11].

Technologically, the anisotropy of individual sections of the fiber is produced using processing with a high-energy laser beam, which moves according to a given program and forms zones with a refractive index (n_3) different from that of the main fiber (n_1) (Fig. 3) [12].

Minimization of optical losses is achieved by matching the optical characteristics of the optical fiber elements: matching the reception and transmission spectra of the optical signal, ensuring structural compatibility, determining and setting critical dimensions in the fiber optic cable, etc. (Fig. 4) [13].

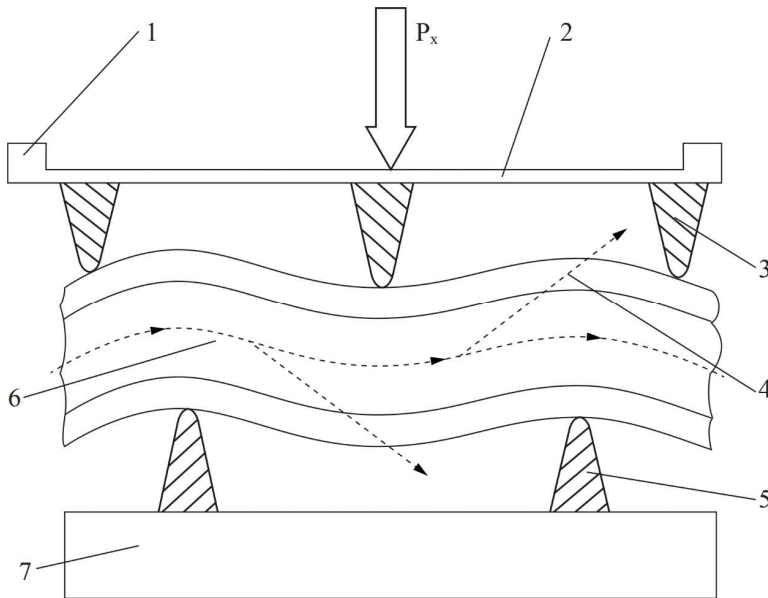

Fig. 2. Fiber optic measuring module with multi-bending fiber: 1 – elastic element, 2 – membrane, 3 – upper stops, 4 – path of optical beams leaving the fiber, 5 – lower stops, 6 – center optical beams remaining in the optical fiber, 7 – rigid base

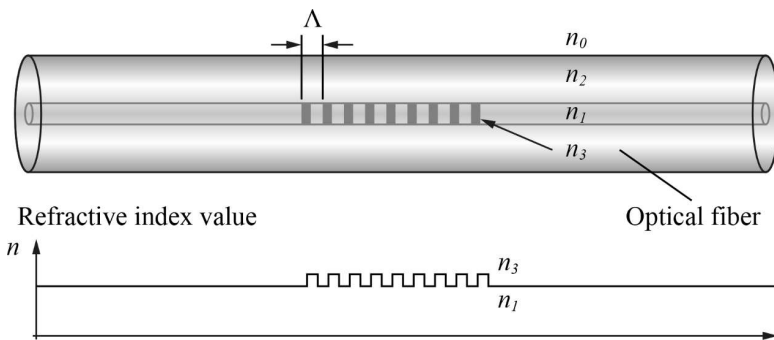

Fig. 3. Diagram of a fiber-optic sensing element with WBG [12]

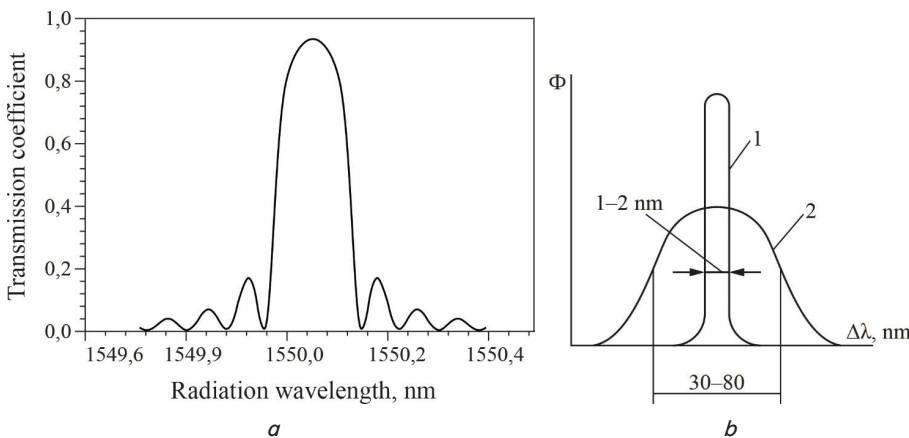

Fig. 4. Optical spectra: a – WBG; b – laser (1) and LED (2)

Currently, measures are being taken to obtain ready-made sensitive elements with formed phase replicas. The search for secondary equipment is also carried out - an inexpensive analog interrogator for the manufacture and testing of the developed layouts of multifunctional fiber optic sensors.

One of the sources of error in optical channels are sources and receivers of radiation. In practice, LEDs and laser

diodes are used as emitters, and photodiodes are used as receivers.

Laser and light-emitting diodes produce widely diverging light beams; therefore, for efficient introduction of radiation into the fiber, a gap is set between the emitting surface and the fiber end face, not exceeding 2–4 diameters of its core. It is also necessary to ensure the spectral compatibility of the light source and the optical fiber. Glass fibers have two regions of minimum signal attenuation from 800 to 850 nm and around 1050 nm. Semiconductor laser diodes have a narrow radiation pattern and deliver an output power of 5–10 mW. But lasers have a significant drawback: their output power is highly temperature dependent.

All the variety of reasons causing losses can be divided into four groups: parametric, constructive, technological and operational.

Parametric losses are due to the internal properties of the used element base - attenuation, spectral characteristics, diameter, numerical aperture and other parameters of the fiber.

Structural losses are associated with the features of the FOS design solution. This type of loss includes losses due to bending of the fiber inside the sensor housing, from branching and combining of the optical signal, reflection, loss of input and output of radiation.

Technological losses are caused by instrumental errors in the manufacture and assembly of detachable optical connectors, as well as losses arising from fiber splicing.

Operational losses are associated with the influence of external operational factors: time, temperature, pressure, humidity, acoustic noise, etc.

The weak point of all fiber optic sensors is the unit for the introduction of optical radiation in the optical fiber, since there are significant losses in the radiation power of the radiation source. These losses are significant if the area of the fiber core is less than the emitting surface. Therefore, it is necessary to choose a fiber with a large cross section.

Another factor affecting these losses is the ability of the fiber to collect light. Light arriving at an angle less than half the angle of the receiving cone of the core propagates along the fiber (Fig. 5). Some of the light arriving at a large

angle is lost in the shell. For an optical fiber with a stepped change in refractive index, the angle of the receiving cone is approximately equal to $\alpha=29$. Fig. 5 shows the distribution of optical radiation from the emitter to the optical fiber [14].

Fig. 6 shows the experimental data obtained by taking into account the losses in the optical channels of laboratory samples of FOS pressure and temperature. The graph was built on the basis of data obtained during tests on a tooling

equipped with a micro-displacer. Moving the platform with the fixed ARS(Fig. 5) from and to the optical fiber, the intensity of the light flux incident on the optical fiber was measured. The experimental data were presented as a graphical dependence (Fig. 6 [14]). The accuracy of the experimental data corresponds to the microdisplacement accuracy, which is 10 μm.

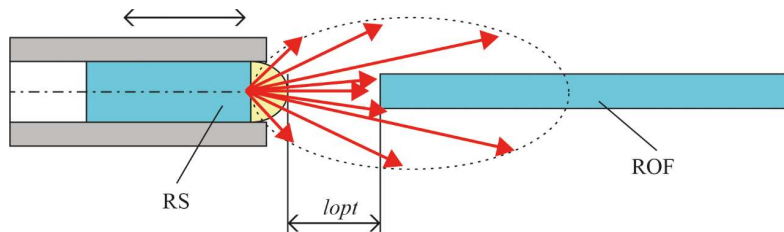

Fig. 5. Model for ensuring the gap between the radiation source (RS) and the receiving optical fiber (ROF) [14]

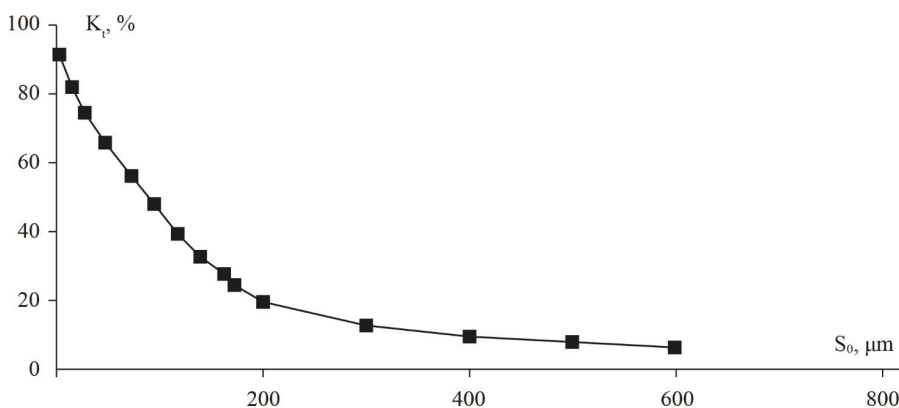

Fig. 6. Graphical dependence of the transmission coefficient of optical radiation (K_p) on the gap (S_0) [15]

When choosing an FOS element base, first of all, it is necessary to take into account the OF transmission at the operating wavelength or in the operating wavelength range. Losses of commercially available optical fibers at a wavelength of 0.85 μm usually do not exceed 2–3 dB/km.

The attenuation of the signal power in the section from the source to the radiation receiver is largely determined by the degree of consistency of the spectral characteristics of the elements of the conversion path of the FOS in the operating wavelength range. When used as an emitter of a 3L107B LED (Russia), and as a photodetector of an FD-256 photodiode (Russia) and a quartz multimode optical fiber of the TKO.735.123 TU type (Russia), the spectral power

losses in the wavelength range from 0.85 to 0,96 microns are about 4 dB.

The main type of structural loss is the presence of a gap between the fiber end face and the radiation source, as well as between the fiber end face and the photodetector (Fig. 5). Losses from the presence of a gap (B_3) can be calculated using the analytical model [2]:

$$B_3 = 10 \lg \left[1 + \frac{d(NA)}{a} \right], \tag{1}$$

where NA – numerical aperture of the fiber; a – current gap between the radiation source and the receiving OF.

5.2. Constructive and technological methods for increasing the sensitivity and expanding the capabilities of fiber-optic sensors

5.2.1. Fiber-optic pressure and temperature sensors with amplitude modulation of the luminous flux

One of the realized FOS structures based on amplitude modulation of optical radiation is shown in Fig. 7.

The prototypes of the designs of the combined pressure and temperature FOS analyzed in the course of the patent search can be as follows.

RF patent (Fig. 8), in which SE 4–5 has a bimetallic structure that reacts to temperature, simultaneously measuring the pressure from the effect of mechanical load on the profiled membrane [16].

An interesting example of a distributed pressure and temperature sensor is a pressure and temperature fiber optic sensor, which can be installed on various products – Fig. 9.

The implementation and study of three FOS options is accepted:

- with amplitude modulation of the generated optocoupler by pressure and temperature (Fig. 10).
- with phase-frequency modulation due to the use of Bragg gratings formed on the optical fiber (Fig. 11).
- using as a sensitive element based on a microelectromechanical structure, connected to an optical module (Fig. 12).

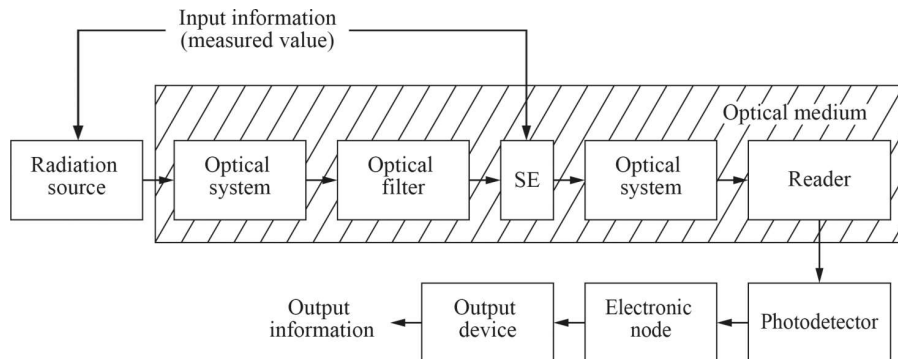

Fig. 7. Block diagram of FOS with optical nodes

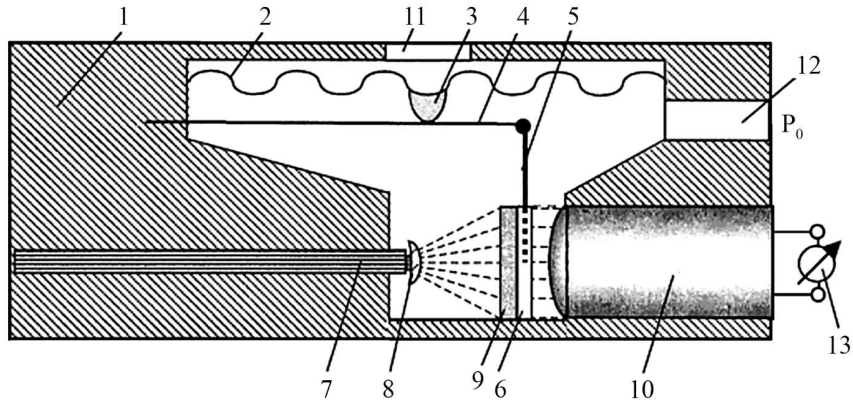

Fig. 8. Pressure and temperature FOS [16]

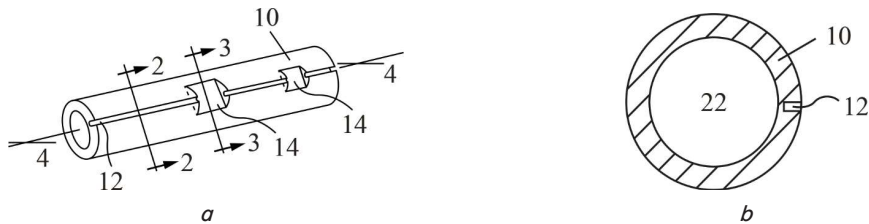

Fig. 9. Distributed FOS of pressure and temperature: *a* – FOS section; *b* – FOS cross section [17]

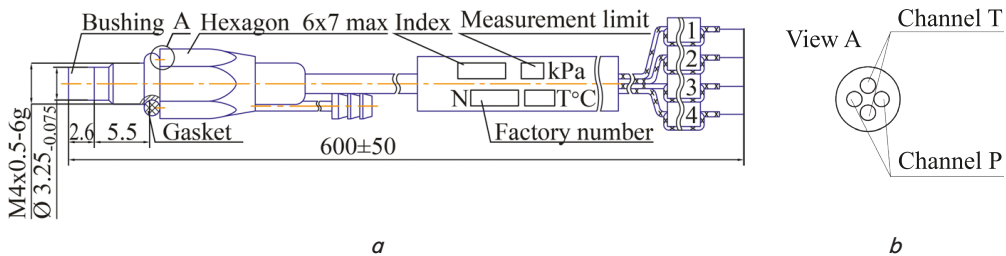

Fig. 10. The design of the 2-channel pressure and temperature ETF: *a* – overall size; *b* – view from the receiving cavity

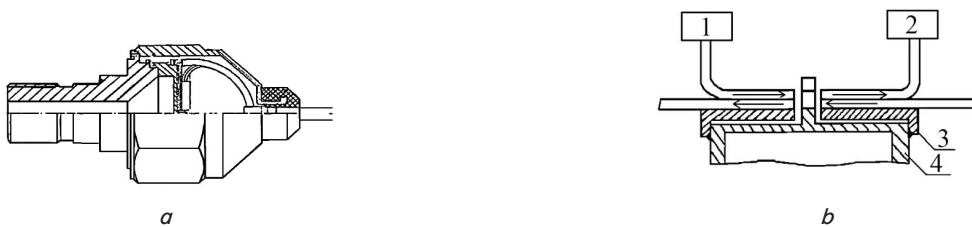

Fig. 11. Sketches of the FOS construction with amplitude modulation of the optical signal and its sensitive element: *a* – FOS; *b* – sensitive element; 1 – emitter; 2 – receiver; 3 – optical fiber holder; 4 – diaphragm

Miniaturization of size and expansion of functionality, FOS can be achieved using integral technologies and methods of permanent connection of semiconductors and dielectrics (Fig. 13 [18]).

The prototype of the pressure-sensitive element was implemented on an experimental technological base equipped with a set of equipment (vacuum units, diffusion furnaces, electrostatic welding units, etc.). As shown by tests of laboratory samples, the test results showed satisfactory results.

In the process of developing a small-sized pressure and temperature FOS, unified sensing elements were proposed and implemented that convert pressure and temperature into the amplitude of optical radiation. These design and technological features are shown in Fig. 14.

In a modular sensitive element (Fig. 13, a), the temperature is measured by changing the dimensions of the structure: mirror (5) – support rod (6) by changing the linear dimensions of the elements. When changing the dimensions, the gap between the end of the opto-splitter (11) and the hemispherical mirror (5) decreases or increases.

In a modular sensitive element (Fig. 13, b), the change in size from the influence of temperature due to the choice of materials is minimized. An informative change in the size of the gap occurs due to the movement of the measuring element when pressure is applied. The measuring element is connected to a profiled elastic element (13), which moves when pressure is applied.

The laboratory models of the developed FOS are shown in the form of photographs in Fig. 14.

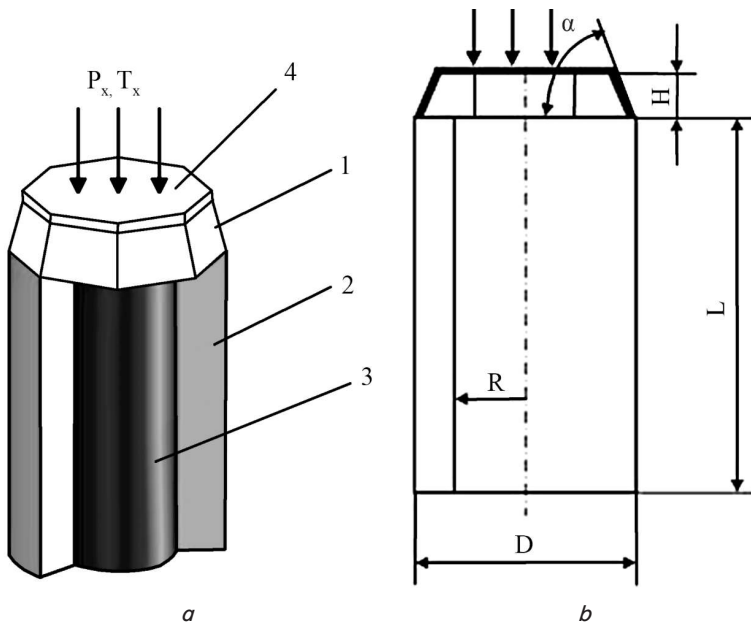

Fig. 12. Design and diagram of the fiber-optic barothermosensitive element: *a* – SE design; *b* – SE scheme: 1 – silicon plate (silicon doped with boron); 2 – fiber cladding (quartz glass); 3 – fiber core (germanium-doped quartz glass); 4 – metal film (gold, aluminum) 100 nm thick

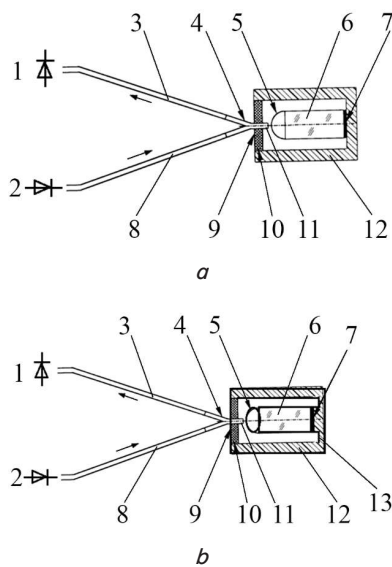

Fig. 13. Modular sensitive elements of multifunctional FOS: *a* – temperature; *b* – pressure; 1 – photodetectors; 2 – light emitters; 3 – receiving light guides; 4 – fiber optic splitter; 5 – micromirror; 6 – support rod; 7 – adhesive layer; 8 – light-supplying optical fiber; 9 – plug; 10 – gluing area; 11 – end of the opto-splitter, 12 – housing; 13 – groove



Fig. 14. Photos of laboratory models of FOS pressure and temperature

5. 2. 2. Study of the FOS technical characteristics

When testing with loading pressure, a deadweight tester of absolute and gauge pressure “MPA 0.5” was used as a reference equipment. In thermal tests, a Tabai-71 heat and cold chamber was used as a reference equipment.

Pressure test method:

- install the sensor on a deadweight tester of the MPA 0.5 type;
- turn on the power supply to the sensor;
- measure the zero level of the signal from the pressure channel by measuring instruments and write down its value (Table 1);
- put a weight corresponding to range 1 on the pressure gauge, write down its value in Table 1;
- consistently increase the load by placing additional weights to complete the direct course of the load (*pr* *);
- successively decreasing the load and writing down the values of the output signals in the column *arr* **, complete the reverse run of the load;
- to collect statistics, perform 4 load-unload cycles.

Table 1

Shows the results of studying experimental FOS samples in the pressure measurement mode

Pressure, MPa	Output voltage U_{out} , mV							
	Cycle 1		Cycle 2		Cycle 3		Cycle 4	
	<i>dir</i> *	<i>indir</i> **	<i>dir</i>	<i>indir</i>	<i>dir</i>	<i>indir</i>	<i>dir</i>	<i>indir</i>
0	-0.74	-0.78	-0.73	-0.78	-0.82	-0.75	-0.75	-0.75
0.05	11.03	11.00	11.03	11.10	11.06	11.00	11.03	11.06
0.1	22.60	22.60	22.54	22.53	22.59	22.59	22.56	22.60
0.15	33.39	33.43	33.41	33.47	33.46	33.44	93.39	33.48
0.2	43.83	43.79	43.81	43.82	43.80	43.84	43.75	43.81
0.25	53.52	53.53	53.52	53.49	53.56	53.47	53.47	53.55
0.3	62.98	62.98	62.92	62.94	62.97	62.99	63.00	62.97
0.35	71.60	71.61	71.60	71.61	71.67	71.64	71.64	71.67
0.4	80.05	80.05	80.04	80.03	80.10	80.07	80.11	80.07
0.45	87.93	87.94	87.91	87.86	87.86	87.87	87.88	87.90
0.5	95.45	95.36	95.45	95.41	95.37	95.40	95.44	95.42

Note: *dir* *, *indir* ** direct and indirect stroke of pressure loading

Thermal tests of the temperature channel were carried out according to the shown diagram (Fig. 15). The tests were carried out on two sensors FOCDT-1, for which the sensitivity to temperature was obtained:

- $\alpha_1=3.34$ mV/°C;
- $\alpha_2=4.13$ mV/°C.

All data on measuring the output signal of the temperature channel are presented in Table 2.

Analysis of the structures and assemblies of laboratory FOSs of pressure and temperature with amplitude modulation of the optical beam presented in the studies showed the possibility of their manufacture and operation without complex hardware and software.

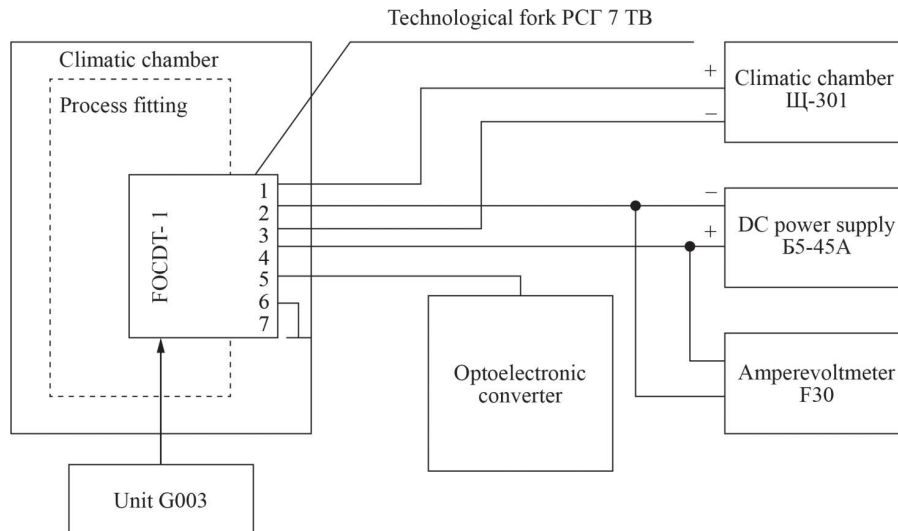

Fig. 15. Block diagram of thermal tests of the temperature channel of the VOCDT-1 sensors

Table 2

Control of the output voltage of the temperature channel FOCDT-1

No. of sensor	Output voltage U_{limt} at temperatures, mV										
	-70	-50	-30	-10	0	+20	+40	+60	+80	+100	+120
1	426	324	225	142	107	36.6	-30.4	-87.9	-138	-183	-221
2	576	442	305	200	70	56.1	-22	-99.4	-157	-208	-270

5.3. Technological processes for the manufacture of multifunctional fiber-optic sensors

One of the most advanced directions in fiber optic technology and in fiber optic technology is the modification of the properties of optical fibers and sensitive elements. The modification consists in doping glass (quartz) optical fibers with various elements, which makes it possible to change the emission spectra and increase the operating temperature [12, 13].

Some optical fibers are deliberately doped with two different types of rare earth ions. The most popular is the combination of erbium and ytterbium (erbium – ytterbium fibers) – usually with a significantly higher concentration of ytterbium. When such fibers are pumped, for example, around 980 nm, most of the excitation light is absorbed by ytterbium ions (called ion sensitizers), returning them to an excited state. From there, energy can be efficiently transferred to erbium ions, which then provide laser gain in the spectral range of 1.5 μ m. Compared to pure erbium fiber, Er-Yb (erbium-ytterbium) fibers have a significant disadvantage. They have a large pump absorption coefficient per unit length. Therefore, these fibers can be used, for example, in distributed feedback lasers. This is useful for creating reliable single frequency fiber lasers with a length of several centimeters. In addition, these optical fibers are well suited for devices on optical fibers with double cladding and short length [14, 19].

The structural model of the technological process of manufacturing the amplitude combined pressure and temperature FOS is shown in Fig. 16.

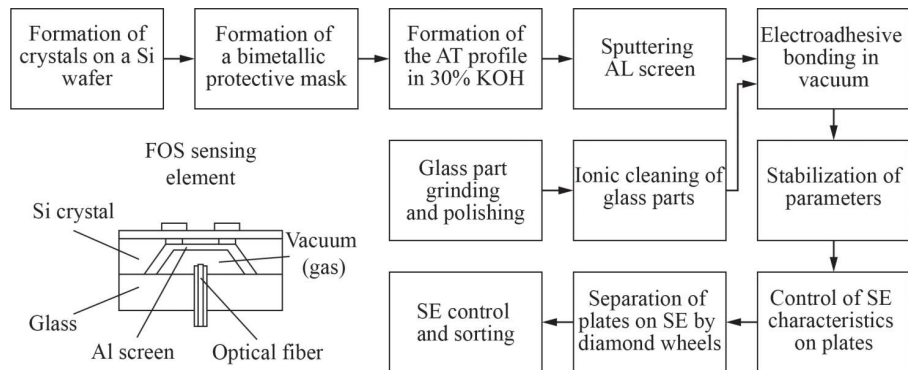

Fig. 16. Technological process of manufacturing amplitude FOS of pressure and temperature

From Fig. 16 it is possible to see that the manufacture of FOS according to the proposed technology is not unique, since almost all operations are standard.

6. Discussion of the research results of the development of multifunctional fiber-optic pressure and temperature sensors

As a result of the research, methods and means of converting the measured physical quantities: pressure and temperature have been identified. The revealed methods and designs of FOS are compatible with the requirements of functioning in the harsh conditions of the rocket and space infrastructure.

It has been found that for the implementation of FOSs based on frequency and phase conversion methods, a complex and expensive optical analyzer (interrogator) and corresponding programs are required. For measuring channels based on one FOS, such a solution is not economically feasible.

A distinctive feature of the proposed methods, designs and technologies in comparison with the known [2, 14, 20] is the modularity of the FOS design, consisting of a microelectromechanical sensitive element and an optical unit.

In this case, the removable microelectromechanical module serves to perceive a specific physical quantity, and its internal structure is optimized for the measured physical quantity. For example, a profiled silicon membrane with a reflective surface, on which an aluminum film is applied, is used to perceive pressure, and a bimetallic film, for example, chromium-aluminum, is sprayed onto the silicon membrane or beam to measure the temperature. The second module is permanent; it contains an optical splitter and a connector.

This combination of a replaceable MEMS module and a permanent optical module makes it possible to simultaneously measure several physical quantities, in particular, pressure and temperature, vibration and temperature, etc.

The tests carried out on experimental samples of pressure and temperature FOS on reference test equipment showed that the direction of modular structures presented in the article is promising in the development of mechanical values of FOS. The results of stress and thermal tests have demonstrated their sufficient sensitivity, which meets the requirements in space technology.

The modern technologies of fiber optic optical fiber fabrication based on the use of excimer lasers for the formation of zones with optical inhomogeneity are considered. In this case, it is possible to combine heat-sensitive and strain-sensitive structures located on the same fiber. These structures differ in wavelength: for thermosensitive structures, the wavelength is much longer than that for tenso structures (approximately 5–10 times). Separation of thermal and deformation waves is carried out using an interrogator.

A limitation of the proposed methods and designs is the need for microelectromechanical structures that measure certain physical quantities. Microelectromechanical structures for FOS are not mass-produced, therefore, their manufacture can be adjusted at instrument-making enterprises.

The developed methods and designs require further modeling using programs and models based on mesh and simulation methods: COMSOL, Ansys, Simulink, etc.

For the development of the research results, two points are urgently needed: the solution of issues with the manufacture of MEMS SE for various PV and equipping the developers with modern software packages for modeling.

The analysis of the losses of optical radiation in the pressure and temperature channels was carried out by measuring the radiation losses (Fig. 5, 6) and studying the decrease in radiation in the optical SE (Fig. 13) depending on the gap.

These studies were carried out using a test bench – a micromovement generator [15]. Test data were displayed graphically (Fig. 6). External influences in the form of vibrations up to 5g were set with a laboratory vibrator. Vibrations applied to a prototype FOS with well-fixed SE and embedded optical cables had practically no effect on the operation of the sensor (the vibration signal corresponded to the noise level).

The used models and designs of FOS based on amplitude modulation remove most of the problems that exist with frequency-phase modulation converters containing IIBGs. These main disadvantages include the mandatory presence of a spectrum analyzer, which is uneconomical for single sensors, since the price increases tens to hundreds of times.

In addition, non-standard software is required. In addition, it is difficult to organize in the frequency-phase sensors the combination in the measurement of several quantities [2].

On the other hand, the proposed methods and modular designs imply equipping their measuring module with MEMS – SE, which has its own structure for different PVs. Such modules can be manufactured at a third-party enterprise equipped with simple microelectronic equipment (sputtering equipment, photolithographic equipment, silicon or quartz etching equipment).

A search and justification of physical and technologically compatible methods for converting various PVs, carried out by one sensor, has been carried out. In this case, such PVs as pressure and temperature were considered as the most measurable quantities in the space infrastructure. Multifunctional fiber-optic modular pressure and temperature sensors, which have a modular design, were selected and implemented in laboratory samples (Fig. 10, 14). As shown by tests of laboratory samples, the sensitivity of the pressure channel (Table 1) was 230 mV/Pa, and the temperature channel (Table 2) ranged from 3.34 mV/°C to 4.13 mV/°C.

The existing technological processes and operations for the manufacture of FOS sensitive elements are analyzed, which have shown that there are technologically complex operations for the manufacture of FOS with phase and frequency modulation of radiation parameters. They consist in the laser formation of regions with different refractive indices (Fig. 3, 4). In this case, a powerful excimer, expensive laser is used. In these studies, the traditional technology was used (Fig. 16), in which the MEMS module was manufactured at a third-party enterprise, and the SE was assembled and assembled with a fiber-optic node by the authors.

The results on ensuring temporal and parametric stability can be estimated using the data obtained for the microelectronic sensors described in [9]. In particular, the developed FOS did not require such measures to stabilize the parameters as in microelectronic ones.

7. Conclusions

1. The procedures for creating fiber-optic combined pressure and temperature sensors, applied to space technology, have been analyzed. It has been proved that general industrial fiber optic sensors do not possess the required values of reliability and resistance to external factors. In this regard, the proposed modular approach to organizing the transformation of physical quantities will be technically feasible and applicable in space instrumentation.

2. The main indicators of quality for two directions of WBG sensors, differing in the methods of modeling the optical beam, have been identified, of which the frequency-phase requires complex hardware and software, which is costly and often economically unprofitable. In this regard, the amplitude conversion method was adopted as the simplest and most compatible with existing interfaces.

3. For the basic conversion method, the design and method of conversion of pressure and temperature FOSs using the amplitude modulation method were selected. In this case, the sensor itself is equipped with a MEMS SE, which measures a physical quantity and an opto-module that generates and transmits modulated signals of the temperature and deformation channels. This makes it possible to make

the sensor multifunctional and to reduce their total number in RT telemetry systems.

4. The laboratory models of the pressure and temperature FOS were manufactured and tested, the characteristics of which are close to the theoretical ones. The developed technologies exclude the use of expensive technological equipment, in particular, an excimer laser, as well as systems for forming phase gratings on optical fibers.

Acknowledgement

The work is the first stage of research work of IRN AP08052850 on the topic “Development of designs and technologies for creating small-sized fiber-optic combined pressure and temperature sensors for space infrastructure”, funded by the Ministry of Education and Science of the Republic of Kazakhstan.

References

1. Dasgupta, S., Hayes, J. R., Richardson, D. J. (2014). Leakage channel fibers with microstructured cladding elements: A unique LMA platform. *Optics Express*, 22 (7), 8574. doi: <https://doi.org/10.1364/oe.22.008574>
2. Udd, E. (Ed.) (2008). *Volokonno-opticheskie datchiki. Vvodniy kurs dlya inzhenerov i nauchnykh rabotnikov*. Moscow: Tehnosfera, 520.
3. Balogun, O., Regez, B., Krishnaswamy, S. (2009). Dynamic demodulation of spectral shifts in fiber-Bragg-grating sensors. *SPIE Newsroom*. doi: <https://doi.org/10.1117/2.1200911.1857>
4. Kelleher, P., Nikogosyan, D. N. (2010). Inscription of narrow-band fibre Bragg gratings with 264nm femtosecond pulses. *Optical Fiber Technology*, 16 (4), 212–216. doi: <https://doi.org/10.1016/j.yofte.2010.04.002>
5. Tenderenda, T., Murawski, M., Szymanski, M., Becker, M., Rothhardt, M., Bartelt, H. et. al. (2012). Fibre Bragg gratings written in highly birefringent microstructured fiber as very sensitive strain sensors. *Microstructured and Specialty Optical Fibres*. doi: <https://doi.org/10.1117/12.922556>
6. Cipullo, A., Gruca, G., Heeck, K., De Filippis, F., Iannuzzi, D., Minardo, A., Zeni, L. (2012). Numerical study of a ferrule-top cantilever optical fiber sensor for wind-tunnel applications and comparison with experimental results. *Sensors and Actuators A: Physical*, 178, 17–25. doi: <https://doi.org/10.1016/j.sna.2012.01.044>
7. Fang, X., He, X. Y., Liao, C. R., Yang, M., Wang, D. N., Wang, Y. (2010). A new method for sampled fiber Bragg grating fabrication by use of both femtosecond laser and CO₂ laser. *Optics Express*, 18 (3), 2646. doi: <https://doi.org/10.1364/oe.18.002646>
8. Shilova, I. V., Belskaya, O. A., Sotsky, A. B. (2013). Electrodynamic model of the bending fiber-optic sensor. *Problems of Physics, Mathematics and Technics*, 1 (14), 43–47. Available at: <http://www.mathnet.ru/links/04f7404cdf9fec2edad4b08c79e9200/pfmt220.pdf>
9. Mikhailov, P., Ualiyev, Z. (2020). Sensor stability assurance problems and their relationship with the overall problems of providing system performance quality. *MATEC Web of Conferences*, 329, 03032. doi: <https://doi.org/10.1051/mateconf/202032903032>
10. Roriz, P., Frazão, O., Lobo-Ribeiro, A. B., Santos, J. L., Simões, J. A. (2013). Review of fiber-optic pressure sensors for biomedical and biomechanical applications. *Journal of Biomedical Optics*, 18 (5), 050903. doi: <https://doi.org/10.1117/1.jbo.18.5.050903>
11. Kotiuk, A.F. (2006). *Datchiki v sovremennykh izmereniyakh*. Moscow: Radio i svyaz Telekom, 96.
12. Varzhel', S. V. (2015). *Volokonnye breggovskie reshetki*. Sankt-Peterburg: Universitet ITMO, 65. Available at: <https://books.ifmo.ru/file/pdf/1762.pdf>
13. Belikin, M. N. (2016). *Bystrodeistvuyushee malogabaritnoe ustroystvo registratsii spektralnogo otklika dlia volokonnoopticheskikh datchikov na breggovskikh reshetkakh*. Saint Petersburg, 14.
14. Shachneva, E. A. (2021). *Volokonno-opticheskie informacionno-izmeritel'nye sistemy parametrov zhidkostnykh potokov*. Penza, 222. Available at: https://dissov.pnzgu.ru/files/dissov.pnzgu.ru/2021/shachneva/dissertaciya_shachnevoy_e_a_.pdf
15. Shroeder, R. Dzh., Udd, E. (1997). Pat. No. 2205374 RU. Fiber-optic pressure transducers and pressure measurement system including them. No. 2000102711/28; declared: 02.07.1998; published: 27.05.2003. Available at: <https://patentimages.storage.googleapis.com/cf/4c/10/87b1c0c1c2daca/RU2205374C2.pdf>
16. Tsaplin, A. I., Repin, V. N., Repin, M. V., Aksenov, R. A., Ermakov, N. A. (2004). Pat. No. 2269755 RU. Fiber-optic pressure sensor. No. 2004120829/28; declared: 07.07.2004; published: 10.02.2006. Available at: <http://www.freepatent.ru/images/patents/200/2269755/patent-2269755.pdf>
17. Stoesh, K. U., Boyd, K. D. (2011). Pat. No. 2473874 RU. Distributed optical pressure and temperature sensors. No. 2011103240/28; declared: 29.06.2009; published: 27.01.2013. Available at: <https://patentimages.storage.googleapis.com/32/d3/52/3979afb77d322a/RU2473874C2.pdf>
18. Pat. No. 230588 RU. *Volokonno-opticheskiy datchik davleniya*.
19. Gulyaev, Yu. V., Nikitov, S. A., Potapov, V. T., Chamorovskiy, Yu. K. (2005). *Volokonno-opticheskie tehnologii, ustroystva, datchiki i sistemy*. *Foton-Ekspres*, 6, 114–127.
20. Murashkina, T. I., Motin, A. V., Chukareva, M. M., Torgashin, S. I. (2018). Technology of fabrication of sensitive element of the differential fiber-optic acceleration sensor. *Measuring. Monitoring. Management. Control*, 1 (23), 38–44. doi: <http://doi.org/10.21685/2307-5538-2018-1-6>