

*The objects of research are the designs and manufacturing technologies of a combined fiber-optic sensor. It is used in extreme operating conditions. The essence of the task is to study the constructive and technological compatibility of optical and micromechanical principles of simultaneous measurement of several heterogeneous physical quantities. In this regard, the chosen modular conversion principle solves the problem of combined conversion. The developed design and technology of the electro-adhesive connection make it possible to significantly reduce the internal mechanical stresses in the sensor and thereby increase the stability of the combined sensors in extreme operating conditions. Analytical models linking the magnitude and orientation of internal mechanical stresses with the characteristics of temporary stability for complex structures, as a rule, are absent. In practice, the obtained research results can be applied to combined pressure and temperature sensors, pressure and vibration, etc.*

**Keywords:** *fiber optic, sensor, formation, electro-adhesive, connection, etching, stability, combination of functions*

UDC 681.2.084

DOI: 10.15587/1729-4061.2022.266359

# DEVELOPMENT OF THE DESIGN AND TECHNOLOGY FOR MANUFACTURING A COMBINED FIBER-OPTIC SENSOR USED FOR EXTREME OPERATING CONDITIONS

**Assem Kabdoldina**

PhD, Senior Lecturer

Department of Chemical Physics and Material Science

Al-Farabi Kazakh National University

al-Farabi ave., 71, Almaty, Republic of Kazakhstan, 050040

**Zhomart Ualiyev***Corresponding author*

PhD, Head of Department

Department of Higher Mathematics and Modeling\*

E-mail: zh.ualiyev@satbayev.university

**Nurzigit Smailov**

PhD, Associate Professor

Department of Electronics, Telecommunications and Space Technologies\*

**Feruz Malikova**

PhD, Head of Department\*\*

**Kuralay Oralkanova**

Master of Mathematics, Teacher

CSI D. Kunayev Secondary School

Shkolnaya str., 30, Praporshikova, East Kazakhstan, Republic of Kazakhstan, 070514

**Murat Baktybayev**

PhD, Associate Professor

Department of Robotics and technical means of automation\*

**Dinara Arinova**

PhD, Senior lecturer

Department of Mechanics and Engineering

Auezov University

Tauke khan ave., 5, Shymont, Republic of Kazakhstan, 160012

**Askar Khikmetov**

PhD, Rector

International Information Technology University

Manas str., 34/1, Almaty, Republic of Kazakhstan, 050040

**Aktoty Shaikulova**

PhD, Senior Lecturer\*\*

**Lashin Bazarbay**

MS, Lecturer

Department of Robotics and Technical Means of Automation\*

\*Satbayev University

Satpaev str., 22 a, Almaty, Republic of Kazakhstan, 050013

\*\*Department of Information Technology

Almaty Technological University

Tole bi str., 100, Almaty, Republic of Kazakhstan, 050012

Received date 06.08.2022

Accepted date 17.10.2022

Published date 30.10.2022

**How to Cite:** Kabdoldina, A., Ualiyev, Z., Smailov, N., Malikova, F., Oralkanova, K., Baktybayev, M., Arinova, D., Khikmetov, A., Shaikulova, A., Bazarbay, L. (2022). Development of the design and technology for manufacturing a combined fiber-optic sensor used for extreme operating conditions. *Eastern-European Journal of Enterprise Technologies*, 5 (5 (119)), 34–43. doi: <https://doi.org/10.15587/1729-4061.2022.266359>

## 1. Introduction

Currently, the problem of investigating the possibility of creating a new class of sensors for simultaneous measurement of various physical quantities is becoming more widespread. The creation of the theory of multifactor measurements is a complex process associated with modeling, technological problems, hardware tasks, etc. Currently, the most promising direction is the creation of a number of fiber-optic

sensors (FOS), which, in principle, have versatility, but with the condition of solving a number of complex design and technological problems that still hinder their use in extreme operating conditions. Let's look at them in more detail.

FOS are now increasingly being developed to measure physical quantities (PQ) in many industries, including aviation. FOS are currently being increasingly developed for measuring physical quantities (PQ) in many industries, including space and aviation. This is due to such advantages as

their low power consumption, fire and explosion safety, resistance to radiation effects and informational confidentiality.

The world manufacturers of FOS are Siemens, ABB, Roctest, Weterford, Backer Hughes, Halliburton, Schlumberger and Russian enterprises Omega, Optolink, Intel-Systems. The volume of the market for FOS for extreme conditions, according to the estimates of the marketing company Frost & Sullivan, amounted to about 1.5 billion USD in 2012 and is projected to grow to 4.4 billion USD by 2026.

According to the classification and principle of operation, all FOS can be divided into devices with amplitude modulation of the characteristics of the luminous flux (intensity, optical trajectory) and devices with frequency-phase modulation (with Bragg gratings), in which modulation is carried out due to reflection and refraction of the beam on interferometric elements embedded in the fiber. Amplitude FOS have insufficient temporal and parametric stability, which is associated with the general problem of insufficient stability of amplitude modulation methods. Frequency and phase modulation methods are more stable. On the other hand, for the correct operation of FOS based on frequency and phase modulation, a specialized expensive spectrum analyzer is required. In this regard, the use of single sensors with Bragg gratings is economically impractical. Therefore, it is necessary to develop and apply modular FOS, in which the primary module is an amplitude converter, for example, a beam or membrane, and then a fiber converter comes as the second module, which allows combining the advantages of the amplitude and phase-frequency conversion principles in a single FOS. Thus, the problem of informational and constructive-technological combination and transformation of various PQs by one sensor will be solved.

---

## 2. Literature review and problem statement

---

Sources [1–3] describe the needs for sensors, their specifics in design, technology and subsequent operation. They do not solve the problem of compatibility of simultaneous measurement of different physical quantities by one sensor.

The paper [4] presents the results of research and the design of a two-channel pressure sensor in which the laser beam is modulated by a mirror reflecting surface of a pressure-sensing membrane. The main disadvantage of the sensor and its manufacturing technology is the separation of the laser beam supply channels and the measuring channel, which does not allow organizing another channel for a physical parameter other than pressure. The noted design and manufacturing technology of sensors have a major drawback: the separation of the laser beam supply channels and the measuring channel, which does not allow organizing another channel for a physical parameter other than pressure.

The article [5] describes methods for ensuring the stability of microelectronic sensors by providing constructive solutions (single or multi-layer strain-sensitive films, development of forming technology, etc.). However, this approach does not lead to the possibility of combined transformation and does not provide group manufacturing processes.

The article [6] presents a number of FOS that are used in medicine for various private applications. These FOS cannot be used in extreme conditions, in addition, the process of their manufacture is associated with profiling operations, extraction after heating of quartz fiber, which are poorly controlled processes, which makes it difficult to reproduce them.

The article [4] describes studies of the FOS design based on optoacoustic wave processes. The disadvantages of this method and design are the presence of discharges and shutdowns in conditions of vibrations and significant temperatures.

In the article [7], the designs and results of research of fiber-optic sensors based on interferometric principles of transformation are considered and analyzed. Complex mathematical methods of phase transformation of the output signal are described in detail, with a measurement error of 0.053 % at 280 kPa and a transmission distance of 2 to 20 km. The conversion methods and sensor design are quite complex and it is difficult to measure other parameters.

In the article [8], the existing methods and designs of fiber-optic sensors, applied for use in medicine, are investigated. Rather complex manufacturing technologies are given. The disadvantage is the complexity of manufacturing and the high cost of sensors.

The principal disadvantages of the considered methods and design designs are the difficulty of embedding a channel with a different measurable physical quantity, which most often has an analog form [9].

These approaches to research are not without drawbacks in terms of complexity and low repeatability of technologies and implementation methods, therefore, it is necessary to combine the micromechanical principle of conversion and the use of fiber-optic measurement principles [10].

All this allows to state that it is expedient to conduct a study on the design and technology of creating collocated combined export-optical sensors used for harsh operating conditions.

---

## 3. The aim and objectives of the study

---

The aim of the study is to select informative methods for the conversion and subsequent implementation of a multifunctional sensor based on optical and micromechanical modules.

To achieve the aim, the following objectives are performed:

- to investigate the problematic level of the state of development of multifunctional sensors;
- to analyze the characteristic known structures and methods of measuring various physical quantities using a single sensor;
- research and analysis of technologically and structurally compatible methods of transformation of various physical quantities;
- development of technological processes for manufacturing optical and micromechanical modules;
- development and testing of the combined sensor design.

---

## 4. Materials and methods

---

The object of research is the methods of development and implementation of multifunctional sensors based on combined fiber-optic elements with characteristics that meet extreme operating conditions.

When an analog signal is transmitted to the optical branch of the sensor, interference such as diffusion and other optical effects does not occur.

It is assumed that the electro-adhesive connection technology used in the manufacture of combined sensors does not create mechanical stresses and does not cause inter-channel interference.

When developing technological mathematical models, the nonlinear effects arising from the formation of individual complex compounds in the Silicon–glass system were not taken into account.

The research method is the analysis of radiation transmission processes in an optical fiber and their numerical modeling. Mathematical modeling is based on the equations of geometric and wave optics. The Simulink program was used to develop analytical and numerical models of connection processes. In addition, an electrical circuit simulation program was used.

**5. Results of designs and manufacturing technologies of combined fiber-optic sensors used for extreme operating conditions**

**5.1. Analysis of structures and methods of measuring various physical quantities using a single sensor**

Let's look at the methods of measuring different PQ using a single sensor, for which let's present a generalized FOS structure (Fig. 1).

The FOS structure contains an optical fiber, light emitting (light source) and light receiving devices, an optical sensing element.

Fig. 1 shows that the converter module is simultaneously affected by two measured PQ: pressure and temperature, which have changed their parameters.

An example of PQ modulation is a sensing element circuit in which, under the influence of a light beam, the resistance of a limited section of the load cell or a constant resistance change.

This method allows comprehensive monitoring of the sensor characteristics, on the one hand, measuring pressure by the traditional strain-resistive method, and, on the other hand, monitoring its resistance using an optical beam. The control methods and the principle of introduction of the probing beam are shown in Fig. 2.

As noted earlier, the combined converter module contains a number of opto- and micromechanical structures acting on the optical fiber or on the optical beam itself, which modulate its characteristics Fig. 3 [10].

As an example of designs of distributed optical pressure and temperature sensors is given in [11] – Fig. 4.

The source [12] provides technological assembly methods that do not ensure the stability of the characteristics of the devices.

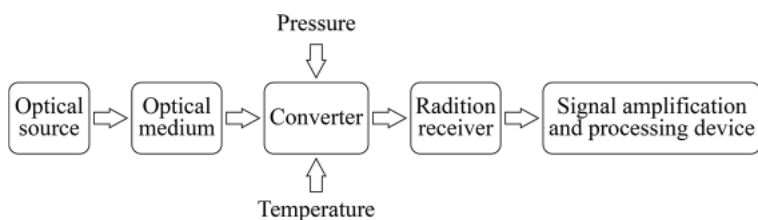

Fig. 1. Structural diagram of fiber-optic sensors (own drawing)

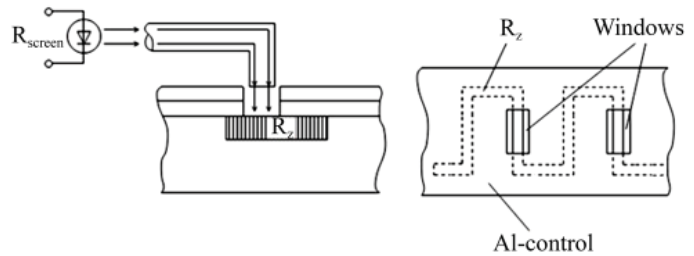

Fig. 2. Load cell resistance control scheme using optical beam feeding via optical fiber (open drawing)

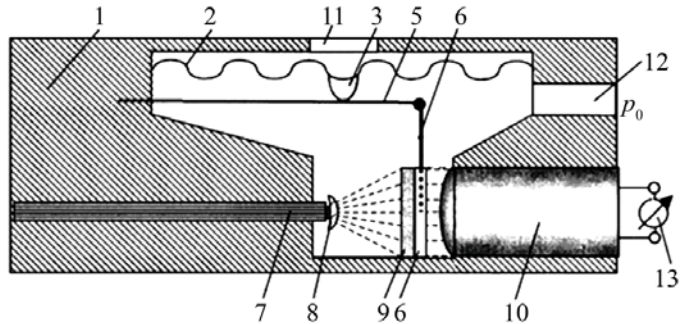

Fig. 3. Scheme of the fiber-optic sensors of pressure and temperature: 1 – case; 2 – corrugated bimetallic membrane; 3 – rigid center, 4 – plate; 5 – curtain; 6 – slot; 7 – fiber optic; 8 – lens; 9 – diaphragm; 10 – photodiode; 11 – measured pressure supply; 12 – reference pressure; 13 – indicator [9]

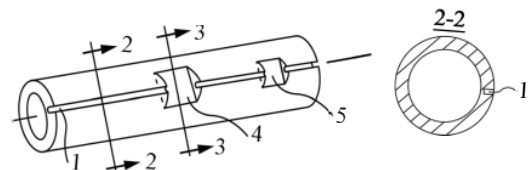

Fig. 4. Distributed optical pressure and temperature sensor [10]: 1 – stress concentrator; 2-2 and 3-3 – cross sections of the sensitive module; 4 – strain-sensitive design; 5 – heat-sensitive design

A fiber-optic carrier having a group of optical sensors located on it, including a sealed hollow shell having a side wall profiled in at least one predetermined area to form a thin-walled part, and in which at least one optical sensor is attached to the surface of the specified thin-walled part in such a way that, at pressure, the pressure difference, the pressure exerted on this thin-walled part bends, and this pressure difference is perceived by at least one sensor, and the sealed hollow shell is a tube.

**5.2. Research and analysis of constructive and technological compatibility of fiber optic sensors**

When conducting a search and subsequent analysis for the structural and technological compatibility of individual elements and assemblies, attention should be paid to the following factors:

- technological operations for the manufacture of sensitive elements should be close and feasible;

- structural elements and their dimensions must be repeated;
- one of the main criteria is the temporal and parametric stability of the electrophysical parameters.

As the analysis of physical phenomena has shown, in relation to fiber-optic and micromechanical structures, the most applicable are phenomena and effects manifested in semiconductor structures, for example, deformations and thermal phenomena, optical effects, mass transfer effects of charge carriers, and so on. At the same time, a very large number of compatible phenomena are observed in nanostructures, although they often have insufficient temporal and parametric stability [13].

### 5.3. Technological features of the manufacture of fiber optic sensors

For micromechanical modular FOS, special technologies are used, which are characteristic of MEMS technologies, in which controlled shaping processes are the main ones. These include: processes: building up materials (formation of metal and insulating films, including a lot of welding, gluing, and soldering); removal of materials (liquid and gas etching, ion and liquid cleaning, etc.) [14].

The technological process of manufacturing a microelectronic FOS is schematically shown in Fig. 5.

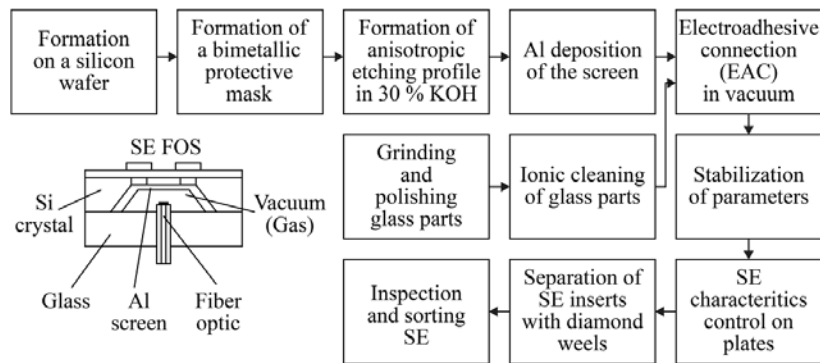

Fig. 5. Manufacturing process of microelectronic pressure and temperature fiber-optic sensors (in the drawing)

Of those indicated in Fig. 5, processes and operations, technologies of controlled building of materials are very important, therefore, let's consider in more detail the specified group of operations [15] – Fig. 6.

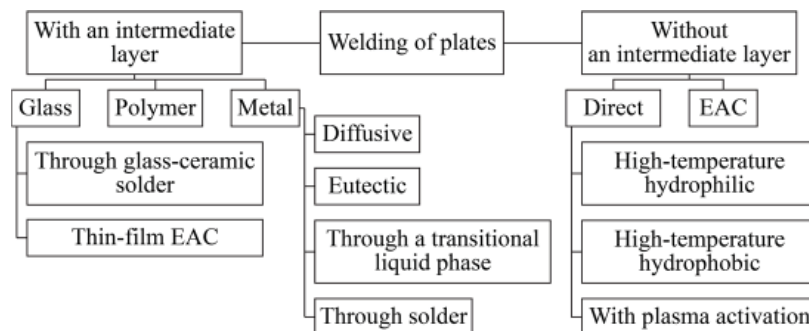

Fig. 6. Classification of methods of building up by welding elements and parts of fiber-optic sensors (own drawing)

The desire to soften the technological modes of joining, to make the technology more controllable and compatible

with group processes of microelectronics and, last but not least, to ensure the joining of miniature parts without degradation of their technical characteristics and destruction, led to the creation of a new direction in the field of creating permanent joints of dissimilar materials – electro-adhesive connection (EAC). Synonyms for EAC, widespread in the scientific, technical and patent literature are: electrostatic bonding, anodic welding, electrodiffusion welding.

EAC of semiconductors and insulators is a promising method for creating micromechanical assemblies of sensors. This is due, first of all, to the absence of degradation of the characteristics of the elements and structures of the sensors in the process of performing permanent connection operations. Let's consider the main processes of EAC [16].

The EAC process consists in the fact that the preheating of the “CE – alkaline glass” assembly promotes the activation of Na<sup>+</sup> and K<sup>+</sup> ions, which are contained in the glass. As the temperature rises, the glass resistance decreases and readily mobile positively charged ions under the action of an applied external electric field begin to move to the negative pole, where they are neutralized. The more strongly bound negative ions remain in place, forming in the glass near the Si surface a spatial negatively charged layer (depleted in positive alkaline ions), and several microns thick. The presence of a built-in charge, in turn, gives rise to mechanical compressive stresses of the order of (0.1...1.0) MPa and an internal electric field with a strength of ~ 3·10<sup>6</sup> V/m [17].

The course of the EAC technological process can be conditionally divided in time into three stages:

- 1) convergence of surfaces before the formation of physical contact;
- 2) activation of the surfaces to be joined, facilitating their chemical interaction;
- 3) mutual diffusion of contacting materials, accompanied by the processes of modification of the structure and properties of materials (crystallization – recrystallization, relaxation of internal stresses, phase synthesis, etc.).

At the first stage, the interacting materials should be brought together at a distance that ensures the Van der Waals interaction (molecular interaction), in which a weak chemical interaction occurs (Fig. 7).

At the stage of formation of physical contact, the main control actions aimed at creating a stable connection are technological parameters: temperature, time, thickness of the gasket. During the EAC process, internal feedbacks are formed that contribute to the formation of a reliable physical contact. This is due to the fact that when the surfaces approach, their electrostatic interaction increases, which, in turn, causes an increase in the compressive force and deformation of the microrelief, intense

deformation leads to an increase in temperature in the contact zone and, as a consequence, to the “flow” of the gasket metal.

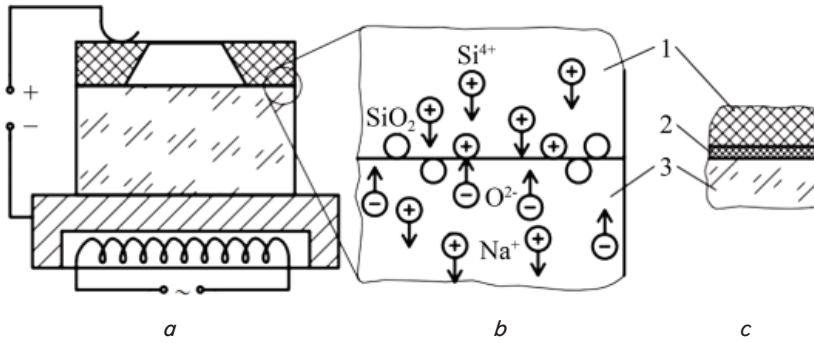

Fig. 7. Illustration of the process of electrostatic connection: *a* – the scheme of supply of the working electric voltage; *b* – the scheme of ion interaction during the process; *c* – the connection area after the completion of the process; 1 – silicon (Si); 2 – silicon oxide (SiO<sub>2</sub>); 3 – glass (own drawing)

It is very difficult to describe mathematically the process of the formation of a physical contact, since several different physical mechanisms act simultaneously. Therefore, in practice, empirical dependences are used, presented in the form of graphs and tables, according to which it is possible to select technological and design control parameters close to the optimal ones.

For EAC, a semi-empirical dependence of the informative parameter  $\tau_\Phi$  (time of formation of physical contact) on technological parameters [18] can be applied:

$$\tau_\Phi = \frac{3\mu R^2 \delta}{p h_0^3}, \quad \delta \text{ and } h_0 \in 2 \text{ mkm} \dots 1 \text{ mm}, \quad (1)$$

where  $\mu$  – viscosity coefficient of the gasket material, depending on pressure and temperature, is determined experimentally,  $R$  and  $h_0$  – respectively, the radius and thickness of the metal spacer [mm],  $\delta$  – height of microroughness of the joined surfaces ( $R_a$  and  $R_z$ ),  $p$  – pressure applied to the joined surfaces.

With EAC, the required connection pressure is formed during the first phase under the action of an applied electrical voltage. This effort can be roughly estimated based on the flat capacitor model:

$$C = \frac{\epsilon \epsilon_0 S}{d}. \quad (2)$$

In this case, a force of electrostatic interaction between the plates arises:

$$F = qE. \quad (3)$$

In turn, the capacity and charge are related by the ratio  $C = \frac{q}{E}$ , and the field strength is  $E = U/d$ . Substituting them into (4) let's obtain:

$$F = \frac{\epsilon_{med} \epsilon_0 S U^2}{d^2}, \quad (4)$$

where  $S$  – area of contact surfaces,  $\epsilon_0$  – electrical constant equal to  $8,854 \cdot 10^{-12}$  F/m,  $U$  the voltage applied to the materials to be joined,  $d$  – depletion region width (average value),  $\epsilon_{CP}$  – dielectric constant of the connection zone.

Taking  $\epsilon_{med} = (\epsilon_{Si} + \epsilon_{gl})/2$ , let's receive  $\epsilon_{Si} = 14$  и  $\epsilon_{gl} = 8$  (table values),  $\epsilon_{med} = 11$ .

To obtain quantitative relationships, let's substitute in (5) the values  $U = 1000$  V,  $d \approx 10 \dots 20$  mcm,  $S = 25$  mm<sup>2</sup> and, converting them into standard dimensions, let's obtain, depending on the width of the transition zone, the values of compressive forces from 6 to 25 Pa. In terms of compression pressure, this will be:

Pascal compression

$$P_{comp} = \frac{F}{S} = \frac{6 \dots 25}{25 \cdot 10^{-6}} \text{ (Pa)} = 2 \cdot 10^5 \dots 10^6 \text{ Pa}.$$

The calculated value of the compression pressure coincides rather closely with the experimental values published in [19].

This value of the compressive pressure ensures the strength and tightness of the silicon-glass connection over the entire surface.

When conducting EAC, control and diagnostics of technological modes is carried out by measuring and analyzing the magnitude and dynamics of the electric current that occurs at the first stage of the connection process.

The first stage of EAC is characterized by the movement of charges Na<sup>+</sup> and K<sup>+</sup>, which are in the glass, in the connection zone. When heating and applying an electric voltage, a characteristic current peak is observed, which characterizes the formation of a physical contact (stage 1) and its rapid decline to almost zero at the end of the heating cycle (Fig. 8). Thus, the magnitude and dynamics of the process of changing the current in the “source – connected parts” circuit are characteristic and unambiguous diagnostic parameters that characterize the course of the EAC process, especially its most important stage – the formation of physical contact.

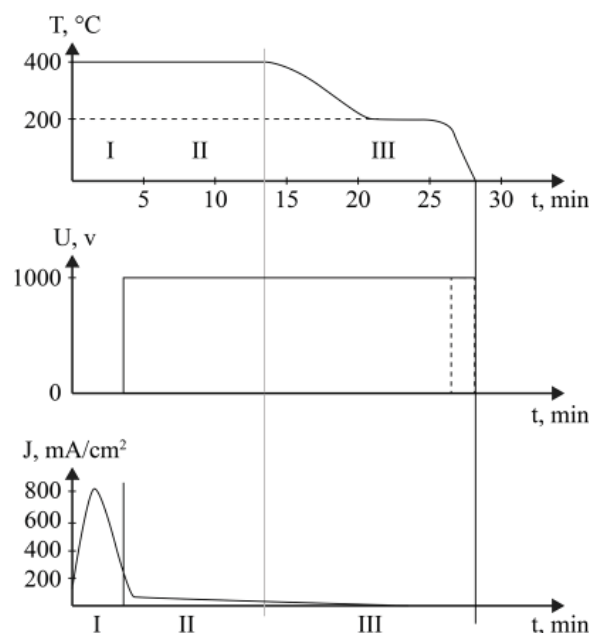

Fig. 8. Cyclogram of the process of electro-adhesive bonding by technological stages (own drawing)

To connect structurally complex multilayer structures, a complex cyclorama is used, in which separate cycles of additional heating are provided Fig. 9. Such cycles reduce internal thermal stresses in the assembly.

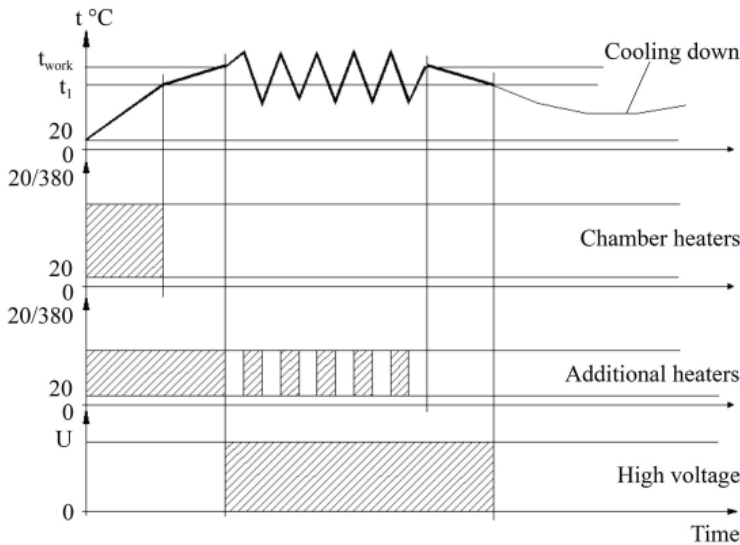

Fig. 9. Cyclogram of the process of electroadhesive bonding of complex multilayer structures (own drawing)

Experimental data on the magnitude and dynamics of ion currents for different glasses are shown in Fig. 10, from which it can be seen that practically after 18–20 minutes the ion current practically stops. The presented dependences are fully consistent with the nature and dynamics of displacement currents observed in dielectrics and caused by their ionic conductivity upon heating, which allows to consider this diagnostic parameter as adequate to physical processes occurring in real physical structures and materials.

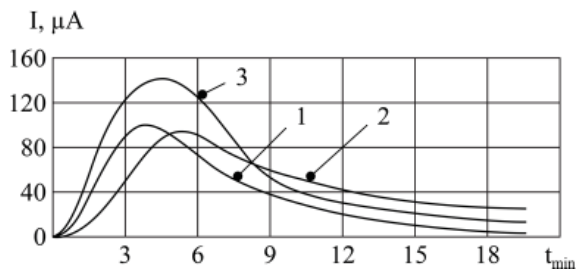

Fig. 10. Dependence of current on connection time for different glasses: 1-C35-1; 2-P15; 3-LK-105 (own drawing)

From the analysis of Fig. 8–10, it can be concluded that the dynamics of the EAC can be controlled by the change in current during the first stage of connection, that is, the nature of the change and the magnitude of the current can be taken as diagnostic criteria for technological process of joining silicon alloy with glass. In addition, the dependence of the current and voltage on the EAC time is important (Fig. 11).

The second stage of EAC is intermediate, since it contributes to the creation of long-term chemical bonds and the formation of an inherently permanent compound (3rd stage). On the active centers of the surface, initiated at the stages of surface preparation (their prehistory), the nucleation of chemical bonds occurs. For a better understanding of both

the activation mechanisms themselves and the possibility of controlling them, let's consider the meaning of the concepts "active surface", "activation center", "activation" in relation to the issues of materials joining under consideration. An "active surface" is a surface with excess energy (according to Gibbs), which is transmitted by means of energetic influences (deformation, ion doping) or chemical reactions (etching, phase formation, etc.). In principle, any clean semiconductor surface is activated by breaking crystal bonds on the surface. Another example is grain boundaries in polycrystalline semiconductors.

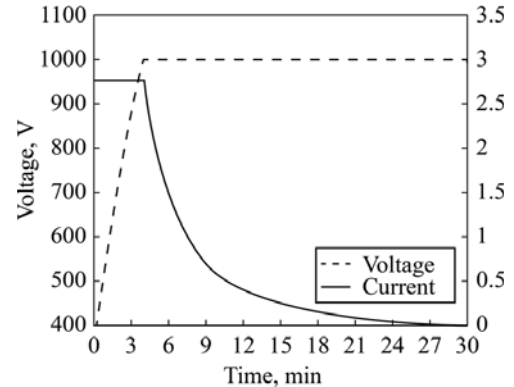

Fig. 11. Dynamics of current and voltage at electro-adhesive connection (own drawing)

According to the laws of thermodynamics, any open system with excess energy dissipates it over time (entropy). Therefore, all activated surfaces are self-passivated by the formation of monolayers of oxides, hydrates, and other silicate compounds, which, by closing broken bonds, contribute to a decr EAC in excess surface energy. From the standpoint of the zone theory, the presence on the surface of impurities, impurities, oxide films, etc. leads to the appearance in the forbidden band, at the bottom of the conduction band or the top of the valence band, shallow, so-called surface levels (sticking levels), often having a high concentration. Due to the high concentration and proximity to the conduction and valence bands, surface levels begin to play a major role in surface phenomena, and a negative one, since they isolate surfaces from interaction with each other even in the case of their physical contact. Thus, to restore the surface activity to the initial one and, if possible, put the EAC into action, it is necessary to clean the surface, up to an atomically pure state (the theoretical limit, achievable only in an ultrahigh vacuum) and its structural rearrangement (modification).

However, since obtaining an atomically clean surface is practically unattainable, a promising direction for increasing the surface activity is its structural modification. The term "modification" means the following concepts: restructuring, changing the properties or characteristics of an object (in our case, the material of near-surface regions) in order to achieve any new results that cannot be achieved by the original material. Surface modification can be obtained, for example, by saturating steel with carbon (surface carbidization), oxidizing the surface of monocrystalline silicon, near-surface microwave hardening of steels and alloys, etc.

#### 5. 4. Development of technological processes for manufacturing optical and micromechanical modules

In the manufacturing process of the measuring transducer (Fig. 5), the three middle blocks relate to the electrical adhesive connection and the operations of preparing parts for connection.

In our case, it is advisable to carry out the structural modification of the surface using more “pure” methods, in particular, energy and ion beams, although various types of heat treatment in vacuum or a combination of the first and second groups of technological methods are not excluded.

The advantages of energetic surface activation methods are:

- purity of the process;
- ability to remove passivating films, organic and inorganic contaminants;
- local nature of processing;
- satisfactory degree of process control.

Effective energy methods of surface activation include:

- treatment in glow discharge plasma;
- processing with electron beams;
- bombardment with ion beams, for example B<sup>+</sup>, P<sup>+</sup>;
- processing with accelerated beams of inert gases He, Ar;
- treatment in fluorine-containing plasma of inert gases.

The general mechanism of surface activation using the above methods consists in one or another degree of its amorphization, since the amorphous structure, in comparison with the crystalline one, has excess energy. In addition, upon activation of the surface, the following effects take place: anisotropic micro-etching; creation of additional dislocation energy levels in the forbidden zone of the crystal; formation of diffusion shallow layers, etc. The dominance of this or that effect depends on such technological factors as ion energy, doping dose, ion charge, accelerating voltage, beam density, substrate temperature, and processing time. Of the listed parameters, the most controllable in the modification process are: impurity dose (depending on current and time), energy (controlled by accelerating voltage), and substrate temperature. In most cases, an increase in the activity of the materials to be joined is associated with the appearance of various kinds of defects, the nature and concentration of which is determined by the interaction of reagents in any solid-phase processes (chemical reactions of sintering, recrystallization) accompanied by EAC processes [20].

In the case of EAC of silicon with different materials, the interaction occurs at active centers, which, from the point of view of the theory of dislocations, are zones of exit of accumulations of defects, which are also zones of concentration of local mechanical stresses that cause microflows and shear of the material in the region of deformation microprotrusions. Within the active centers, there is a rupture and translation of valence bonds between the atoms of the compound being connected [21].

On the side of the glass, micro-risks and micro-cracks arising in the process of grinding and polishing the seating surfaces can serve as active centers. These microcracks, due to their thermodynamic instability at high temperature and pressure, can change their position and geometric direction. The kinetics of crack growth is described by the Griffiths theory, thermodynamic theory, and the theory of strength, according to which, under the influence of temperature and deformation, microcracks, migrating over the surface and volume, merge, forming cluster structures. When the size of

the clusters does not exceed a certain critical value, self-deceleration of cracking occurs due to the closure of local mechanical stresses inside the cluster formations.

From the standpoint of creating the maximum density of active centers on the glass surface, such technological operations as etching and chemical-mechanical glass polishing are hardly acceptable, since the effect of smoothing the microrelief with an isotropic etchant (HF solutions) leads to an increase in the radius of microcracks and, thus, to a decrease their activity and mobility. The control factors at this stage can be the technological preparation of surfaces and their modification [22].

The third, final stage of EAC is accompanied by interdiffusion of contacting materials, crystallization and recrystallization processes, synthesis of complex metasilicate compounds, as a result of which an integral semiconductor-glass-metal or semiconductor-glass compound is finally formed. Due to the processes of activation of the contacting surfaces that occurred at the previous stages, there is a powerful interdiffusion of materials at a relatively low temperature, which is not characteristic of diffusion processes described in the theory of mass transfer (Fick's equations). The presence of powerful diffusion fluxes confirms the fact that the Al film that existed before the EAC disappears and its traces are not detected on the thin section, not only visually, but also when studying by metallographic and spectral methods. Apparently, the Al film binds with the oxygen of the glass, forming Al<sub>2</sub>O<sub>3</sub>, which is initially present in the glass phase (for example, C35-1 contains 1.0 % Al<sub>2</sub>O<sub>3</sub>, LK-105 – 0.89 % Al<sub>2</sub>O<sub>3</sub>) [19].

In addition, as a result of interdiffusion, silicon is enriched with boron (borosilicate glass-BSiO<sub>2</sub> is formed), which is originally a part of the glass. And chemical reactions occurring at active sites lead to the formation of silicides, metal oxides and other stable chemical compounds such as Ni<sub>2</sub>SiO<sub>4</sub>, Al<sub>2</sub>O<sub>3</sub>, Fe<sub>2</sub>SiO<sub>4</sub>, which are characterized by strong bonds and stability.

At this stage, due to the formed zone of volumetric “built-in” charge, the external electric voltage at the end of the cycle is turned off and only the temperature (its absolute value and rate of change) remains the regulating technological parameter. And although this process is irreversible, sometimes the electric voltage is not removed until the unit cools down to room temperature (dashed line in Fig. 10). This technique serves to stabilize the space charge and contributes to the drainage of the remaining nonequilibrium charge carriers to the ground. It should be noted that at this final stage, there is a risk of destruction of the joint due to the internal mechanical stresses previously induced and arising during the cooling process in the joint zone and in the parts themselves.

To remove the induced mechanical stresses, a special (controlled) cooling mode is used, which is carried out together with the technological unit. In order to accelerate stress relief in the assembly during the cooling process, annealing at a temperature for 8..10 minutes should be provided (on the cyclogram – Fig. 9, 10, the temperature “shelf” is visible in the region of 200 °C). After thermal annealing, the cooling rate can be increased practice it is not recommended to do this, since due to the deterioration of the heat removal conditions during the EAC in vacuum or due to the massiveness of the unit itself, the stresses do not have time to dissolve and, accumulating in the parts (glass and silicon),

can lead to their rapid destruction or to the failure of the unit during operation.

Experimental data have shown that the quality of EAC of them is determined mainly by the physico-chemical properties of the glasses used in the bonding process. To a lesser extent, the effect on the quality of the connection depends on the parameters of the silicon wafers. Experimentally, it was found that the roughness of the surfaces of glass and silicon should not exceed 2 nm, and the change in the thickness of silicon along the junction field should not exceed 8-10 microns.

Visually, the quality of the compound was evaluated using a Nicolet DXR Spectrometer dispersion Raman microscope. Residual stresses in the glass before and after heat treatment on the PKS-250 polaroscopic polarimeter. In addition, the amount of residual mechanical stresses was monitored using an infrared Fourier spectrometer Thermo Scientific Nicolet.

### 5.5. Modular fiber-optic pressure and temperature sensors

In the study of the developed combined sensors, a generalizing method of analyzing the structures and materials of sensors was applied.

Let's note some important features of the design and technological operations of modular FOS. Since the analog module of the FOS is a complex heterogeneous structure (Fig. 12), in order to obtain the parametric and temporal stability of the entire FOS, it is necessary to ensure the constructive, functional and technological compatibility of materials.

From the standpoint of materials science, it consists of various materials: metals, alloys, glass, ceramics, semiconductors, insulators, sealants, plastics, etc., for example, titanium and elinvar alloys, stainless steels are used for body and power materials: kovar, and various adhesives and sealants for sealing and permanent joints (Fig. 12). Alkaline, borosilicate, quartz, amorphous and polycrystalline glasses are used as materials for insulators and bearing parts. For the material for insulators and sensing elements, alumina (corundum), mullite ceramics, piezoceramics are used. From semiconductor materials used silicon, and semiconductor compounds silicon carbide, gallium arsenide, semiconductor structures – silicon on sapphire, silicon insulator silicon. For FOS, along with the above materials, one more mode and multimode quartz optical fibers are used.

It is assumed that there are several options for the sketches of the FOS [23]:

1. Amplitude modulation of the generated optocoupler by pressure and temperature (channel P-pressure and channel, T-temperature) – Fig. 13, 14.
2. Phase modulation through the use of Bragg gratings formed on the fiber [24].
3. Using MEMS primary cell [25].

Fig. 14. Constructive models of multifunctional fiber-optic sensors [26].

This version of FOS with amplitude modulation, in which two channels are used: pressure and temperature, which change the intensity of the reflected optical beams.

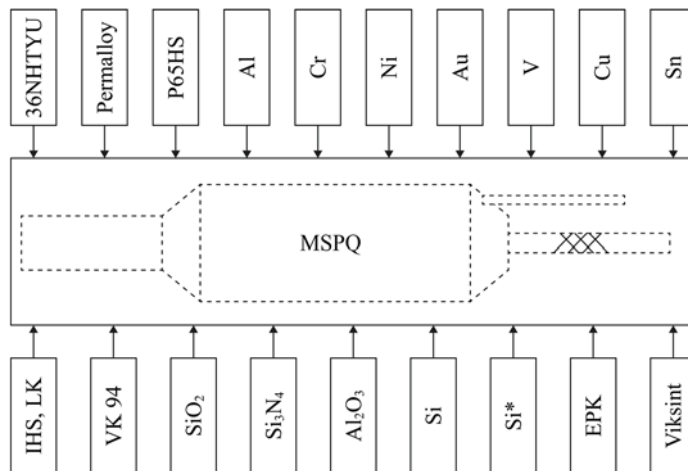

Fig. 12. Microelectronic sensor of physical quantities as a complex heterogeneous system (own drawing)

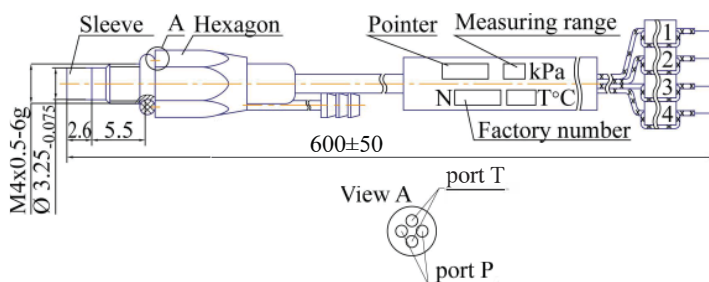

Fig. 13. Design of 2-channel fiber-optic sensors (own drawing)

## 6. Discussion of experimental results research of designs and manufacturing technologies of combined fiber-optic sensors used in extreme operating conditions

Various processing methods were investigated for technological compatibility, it was found that in order for the compound to turn into a single module, it is necessary to treat the connected surfaces by activating them in various ways: treatment in a glow discharge plasma; electron beams; bombardment with ion beams, for example B+, P+; accelerated beams of inert gases He, Ar; treatment of inert gases in fluorinated plasma [20, 21].

The technological process of manufacturing a microelectronic Focus schematically shown in Fig. 5.

To the greatest extent, the purity of the process and the minimization of internal mechanical stresses are ensured by the development and implementation of the EAS technology and the preparation of the quality of the connected parts [18, 19] into a single integral unit (Fig. 7–11).

The classification of methods for modifying elements and parts of fiber-optic sensors is shown in Fig. 6, which makes it possible to expand the manufacturing methods.

The development and testing of the combined sensor design is carried out during the implementation of the manufacturing technology (Fig. 5) and on ready-made sensors (Fig. 13, 14) [20, 26, 27].

It should be noted that in the research on technological support, traditional technology was used (Fig. 5), in which the MEMS module was manufactured at a third-party



enterprise, and the SE was assembled and mounted by the authors themselves. The results of ensuring temporal and parametric stability were evaluated using data obtained for microelectronic sensors described in [11].

The developed methods and constructions require further modeling using programs and models based on simulation methods: COMSOL, Ansys, Simulink, etc. Two things are urgently needed for the development of research results: solving issues with the manufacture of MEMS SE for various photovoltaic systems and equipping developers with modern software packages for modeling.

At the same time, the problem of manufacturing third-party micromechanical modules is one of the main problems that need to be solved.

---

## 7. Conclusions

---

1. The study of known sensor structures and measurement methods has shown the priority of combined sensors in extreme conditions. Such sensors have very high noise immunity, fire and explosion protection and can be used in a wide range of temperatures and pressures.

2. The study of compatible conversion methods revealed their greatest prevalence in the fields of micro- and optomechanics. The group manufacturing methods used in these areas allow the formation of sensor elements with small dimensions and tight tolerances. On the other hand, known measurement methods, for which the main measured parameters are the frequency and phase of optical radiation, require a complex, expensive optical spectrum analyzer. In

this regard, the amplitude conversion method was adopted as the simplest and most compatible with existing interfaces.

3. The advantage of the proposed method of a modular system for measuring physical quantities is hardware simplicity and the absence of requirements for the purchase of programs and training of personnel.

4. The advantages of the proposed connection technology using an electroglue connection are guaranteed stability due to the absence of internal mechanical stresses and the possibility of connecting various small-sized parts.

5. As studies of the quality of the proposed designs of modular sensors and their manufacturing technologies have shown, their production (assembly, control) can be mastered with the help of simple technological equipment. The connection technology can also be implemented using simple equipment and technological process.

---

## Conflict of interest

---

The authors declare that they have no conflict of interest in relation to this research, whether financial, personal, authorship or otherwise, that could affect the research and its results presented in this paper.

---

## Acknowledgements

---

This research is funded by the Science Committee of the Ministry of Education and Science of the Republic of Kazakhstan (Grant No. AP08052850).

---

## References

- Ghorat, M., Gharehpetian, G. B., Latifi, H., Hejazi, M. A., Bagheri, M. (2019). High-Resolution FBG-Based Fiber-Optic Sensor with Temperature Compensation for PD Monitoring. *Sensors*, 19 (23), 5285. doi: <https://doi.org/10.3390/s19235285>
- Mikhailov, P., Ualiyev, Z., Kabdoldina, A., Smailov, N., Khikmetov, A., Malikova, F. (2021). Multifunctional fiber-optic sensors for space infrastructure. *Eastern-European Journal of Enterprise Technologies*, 5 (5 (113)), 80–89. doi: <https://doi.org/10.15587/1729-4061.2021.242995>
- Song, P., Ma, Z., Ma, J., Yang, L., Wei, J., Zhao, Y., Zhang, M., Yang, F., Wang, X. (2020). Recent Progress of Miniature MEMS Pressure Sensors. *Micromachines*, 11 (1), 56. doi: <https://doi.org/10.3390/mi11010056>
- Bai, L., Zheng, G., Sun, B., Zhang, X., Sheng, Q., Han, Y. (2021). High-precision optical fiber pressure sensor using frequency-modulated continuous-wave laser interference. *AIP Advances*, 11 (2), 025038. doi: <https://doi.org/10.1063/5.0035643>
- Korolev, V. A., Potapov, V. T. (2011). Volokonno-opticheskie datchiki temperatury i davleniya v biomeditsine. *Vestnik novykh meditsinskikh tekhnologii tom. XVIII*, 3, 256–258.
- Pevec, S., Donlagic, D. (2014). Miniature fiber-optic sensor for simultaneous measurement of pressure and refractive index. *Optics Letters*, 39 (21), 6221–6224. doi: <https://doi.org/10.1364/ol.39.006221>
- Mendoza, E. A., Esterkin, Y., Kempen, C., Sun, Z. (2011). Multi-channel monolithic integrated optic fiber Bragg grating sensor interrogator. *Photonic Sensors*, 1 (3), 281–288. doi: <https://doi.org/10.1007/s13320-011-0021-8>
- Zhou, N., Jia, P., Liu, J., Ren, Q., An, G., Liang, T., Xiong, J. (2020). MEMS-Based Reflective Intensity-Modulated Fiber-Optic Sensor for Pressure Measurements. *Sensors*, 20 (8), 2233. doi: <https://doi.org/10.3390/s20082233>
- Tcaplin, A. I., Repin, V. N. (2004). Pat. No. 2269755 RU. Volokonno-opticheskii datchik davleniya. MPK: G01L11/02. declared: 07.07.2004; published: 10.02.2006.
- Stoesh, K. U., Boid, K. D. (2013). Pat. No. 2473874 RU. Raspredelemnnye opticheskie datchiki davleniya i temperatury. MPK: G01L11/02. declared: 29.06.2009; published: 27.01.2013.
- Mikhailov, P., Ualiyev, Z. (2020). Sensor stability assurance problems and their relationship with the overall problems of providing system performance quality. *MATEC Web of Conferences*, 329, 03032. doi: <https://doi.org/10.1051/mateconf/202032903032>
- Timoshenkov, S. P., Boiko, A. N., Simonov, B. M. (2010) Metody sborki i montazha maketnykh obratcov mikroelektromekhanicheskikh sistem. *Izvestiya vuzov. Elektron*, 84, 58–63.

13. Ozhikenov, K., Mikhailov, P., Kabdoldina, A., Ualiyev, Zh. (2018). The forming processes of local removal of semiconductor materials in micromechanical devices manufacturing technologies *International Journal of Mechanical Engineering and Technology*, 9 (10), 1356–1367.
14. Andreev, K. A., Vlasov, A. I., Shakhnov, V. A. (2014). Kremnievye preobrazovateli davleniia s zashchitoi ot peregruzki. *Datchiki i sistemy*, 10, 54–57.
15. Sinev, L. S. (2014). Osobennosti ispolzovaniia elektrostatičeskikh soedinenii kremniia so steklom v tekhnologii mikrosistem. *Inzhenernyi vestnik. MGTU im. N.E.Baumana*, 5, 501–509.
16. Khandan, O., Stark, D., Chang, Alexander., Rao, M. P. (2014). Wafer-scale titanium anodic bonding for microfluidic applications. *Sensors and Actuators B: Chemical*, 205, 244–248. doi: <https://doi.org/10.1016/j.snb.2014.08.083>
17. Ushkov, A. V., Kozlov, A. N. (2007). Design, manufacture and research of silicon pressure sensing elements with built-in protection against overload. *Nano- and microsystems. tech.*, 5, 49–51.
18. Dragoi, V., Pabo, E., Burggraf, J., Mittendorfer, G. (2012). CMOS: compatible wafer bonding for MEMS and wafer-level 3D integration. *Microsystem Technologies*, 18 (7–8), 1065–1075. doi: <https://doi.org/10.1007/s00542-012-1439-7>
19. Ran, Z., He, X., Rao, Y., Sun, D., Qin, X., Zeng, D. et al. (2021). Fiber-Optic Microstructure Sensors: A Review. *Photonic Sensors*, 11 (2), 227–261. doi: <https://doi.org/10.1007/s13320-021-0632-7>
20. Mikhailov, P. G. (2021). Modeling the Influence of the Edge Electrostatic Effect on the Transformation Function of Thin-Film Quasi-Differential Capacitive Sensitive Elements. *Journal of Physics: Conference Series*, 2096 (1), 012143. doi: <https://doi.org/10.1088/1742-6596/2096/1/012143>
21. Wang, Y. (2012). Fiber-Optic Sensors for Fully-Distributed Physical, Chemical and Biological Measurement. Blacksburg. Available at: [https://vtechworks.lib.vt.edu/bitstream/handle/10919/19222/Wang\\_Y\\_D\\_2013.pdf?sequence=1](https://vtechworks.lib.vt.edu/bitstream/handle/10919/19222/Wang_Y_D_2013.pdf?sequence=1)
22. Bachin, V. A. (1986). *Diffuzionnaia svarka stekla i keramiki s metallami*. Moscow: Mashinostroenie, 184.
23. Ouyang, Y., Guo, H., Ouyang, X., Zhao, Y., Zheng, Z., Zhou, C., Zhou, A. (2017). An In-Fiber Dual Air-Cavity Fabry–Perot Interferometer for Simultaneous Measurement of Strain and Directional Bend. *IEEE Sensors Journal*, 17 (11), 3362–3366. doi: <https://doi.org/10.1109/jsen.2017.2693501>
24. Pargfrieder, S. et al. (2004) New low temperature bonding technologies for the MEMS Industry. The 6th Korean MEMS Conf.
25. Yufeng, J., Jiaxun, Z. (2005). MEMS Vacuum Packaging Technology and Applications. 2005 6th International Conference on Electronic Packaging Technology. doi: <https://doi.org/10.1109/icept.2005.1564710>
26. Chernov, A. S., Samorodov, A. L., Khabarov, S. P., Gridchin, V. A. (2016). Fotočuvstvitelnyi element dlia sensora davleniia s optičeskoj prostranstvennoi moduliatciei. *Nano- i mikrosistemnaia tekhnika*, 18 (7), 416–423.
27. Sinev, L. S., Riabov, V. T. (2011). Soglasovanie koeffitientov termičeskogo rasshireniia pri elektrostatičeskom soedinenii kremniia so steklom. *Mikro- i nanosistemnaia tekhnika*, 5, 24–27.