

One of the tools to confirm the origin of electricity sold in the retail market are the so-called Guarantees of Origin. They are the basis for calculating greenhouse gas emissions and reporting on carbon emissions and are the most sought-after by European enterprises.

The object of this study is the mechanism of labeling guarantees of the origin of electricity in electrical networks with renewable energy sources, taking into consideration their location and schemes of connection to the power grids.

Existing solutions for electricity labeling based on the certificates of Guarantees of Origin have a number of problems. They often do not accurately reflect carbon emissions, do not provide transparency and verifiability for end users because they do not take into consideration the physical processes of electricity transmission in the labeling system.

To solve this problem, a method has been developed that makes it possible to isolate from the flow of energy in each power transmission a component due to each connected energy source. As a result, the proportion of the load of each node of the electrical network supplied by a certain source of electricity is determined. To take into account the non-linearity of the ratio between voltages in the nodes of electrical networks and flows in power transmissions, piecewise-linear approximation is used.

The algorithm for issuing guarantees of the origin of electricity has been improved. It takes into consideration not only indicators of the balance of electricity but also the results of assessing the volume of electricity supply to each consumer from renewable sources. Thus, the volume of sales of guarantees of origin is limited depending on the placement of consumers and their connection to the power grid. Directing proceeds from the sale of guarantees of origin to the guarantors of «green» subsidies will provide them with additional financial support to compensate for the costs of the «green» tariff

**Keywords:** renewable energy, guarantees of origin, carbon regulation, green tariff, blockchain

# DEVISING A METHOD FOR ESTIMATING THE SHARE OF ELECTRICITY CONSUMPTION BY A GIVEN CONSUMER, WHICH IS PROVIDED FROM RENEWABLE ENERGY SOURCES

**Petro Lezhniuk**

Doctor of Technical Sciences, Professor\*

**Oleksandr Burykin**

Corresponding author

PhD, Associate Professor, Head of Department

Department of Energy Balances and

Technological Energy Losses Standardization\*\*

E-mail: mr.burykin@gmail.com

**Volodymyr Kulyk**

Doctor of Technical Sciences, Associate Professor\*

**Juliya Malogulko**

PhD, Associate Professor\*

**Andriy Polishchuk**

PhD, CEO\*\*

**Artur Sytnyk**

Postgraduate Student\*

\*Department of Electrical Stations and Systems

Vinnitsia National Technical University

Khmelnyske highway, 95, Vinnitsia, Ukraine, 21021

\*\*JSC «Vinnitsiaoblenergo»

Magistratska str., 2, Vinnitsa, Ukraine, 21050

Received date 15.08.2022

Accepted date 20.10.2022

Published date 30.10.2022

**How to Cite:** Lezhniuk, P., Burykin, O., Kulyk, V., Malogulko, J., Polishchuk, A., Sytnyk, A. (2022). Devising a method for estimating the share of electricity consumption by a given consumer, which is provided from renewable energy sources. *Eastern-European Journal of Enterprise Technologies*, 5 (8 (119)), 21–30. doi: <https://doi.org/10.15587/1729-4061.2022.265749>

## 1. Introduction

Climate change is the main prerequisite for the implementation of sustainable solutions for the production of electricity based on renewable energy sources (RES). The rapid progress of technology makes solutions for energy production and storage more accessible to consumers and allows them to become responsible participants in the energy process. The real success of solutions in the field of energy using inexhaustible sources depends not so much on technological readiness, which already largely exists, but on consumers' awareness of the feasibility of using RES. In European countries, active research is being conducted on consumer

behavior when making decisions about the use of energy from renewable sources by comparing economic, environmental, and social benefits. Therefore, a number of European countries are introducing non-economic incentives that play an important role [1]. Consumers are willing to pay more for a positive social norm for the use of environmental innovations despite the lower cost-effectiveness of solutions [2].

One of the tools for confirming the origin of energy sold in the retail market are the so-called Guarantees of Origin (GO). The GO is an effective tool for decarbonizing the economy, the basis for calculating greenhouse gas emissions into the atmosphere for reporting carbon emissions and is the most sought-after by European enterprises. The GO is also a tool

to support renewable energy sources on European trading platforms. RES sell GO to traders or retail suppliers. Those, in turn, offer them further to interested commercial consumers. The main economic incentive is reduced taxation, since all electricity in European countries is subject to a «carbon» tax, with the exception of electricity produced from RES.

One of the key strategic goals and an important component of Ukraine's energy security is the integration of its integrated energy system into ENTSO-E. Therefore, research in this area is becoming relevant for this state. Given the importance of electricity exports, the existence of a functioning mechanism of Guarantees of Origin will become of particular importance after the adoption of the Law of the European Union (EU) on the «Green Deal» and the introduction of the Carbon Border Regulation Mechanism in 2023 [3].

Increasing the share of RES in the country's energy balance under the conditions of the electricity market, taking into consideration social norms aimed at introducing environmental innovations, actualizes the problem of providing consumers with energy from renewable sources. It is not possible to physically implement the process of targeted supply of electricity under the conditions of parallel operation of different types of power plants in the system. However, for each consumer it is possible to reasonably estimate the share of electricity consumption, which is provided from renewable sources. This task is dynamic. Constant changes in the load of consumers and the generation of RES, in particular due to meteorological conditions, lead to changes in the structure of the balance of electricity in the power system. Changes in the structure of the revenue side of the electricity balance affect the share of electricity consumption of an individual consumer, which is covered with RES. In addition, the places of their connection to the networks, as well as the schedules of generation and consumption, do matter.

Thus, the development of a method for calculating the constituent flows of electricity to a certain consumer, due to the generation and consumption in the nodes of the electrical network (EN), is an urgent task.

---

## 2. Literature review and problem statement

---

In European countries, the use of «green» electricity GO is aimed at achieving the goals of the Paris Charter on the regulation of measures to reduce carbon dioxide emissions from 2020, concluded to replace the Kyoto Protocol.

According to experts, to achieve the goals of the Paris Charter, the necessary conditions are the complete electrification of the heating and transport sector [4], as well as the transition to the use of «green» hydrogen for industrial production of process heat [5]. That is, the total electricity consumption will increase, which in the future will lead to 100 % of electricity production from RES [4, 6].

Since covering 100 % of future electricity use with renewable energy has been unattainable for at least ten years [7], the issue of determining the share of «green» energy supply is relevant. This is necessary for both renewable energy producers and industrial consumers seeking to reduce CO<sub>2</sub> emissions [8]. In addition to the environmental aspect, this is mainly due to the need for verifiable reporting [9]. After all, shareholders require disclosure of the volume of CO<sub>2</sub> emitted as a result of the activities of enterprises [10].

Thus, energy labeling or distribution of renewable energy certificates and related guarantees of origin is a hot topic in

energy business models [11]. Such systems exist in Europe where they are called Guarantees of Origin, in the USA, and Asia [12]. That is, the Guarantee of Origin is an electronic document issued at the request of the RES manufacturer for provision to the final consumer. The GO certifies that the megawatt-hour of electricity was produced in a certain month and contains information about the power plant: technology, age, location, availability of subsidies, etc.

The use of GO involves the use of specialized systems and software that allow them to keep records, the release and cancellation of them. To build such systems, researchers offer different models of information exchange that have advantages and disadvantages.

Paper [12] provides an analysis of the functioning of the European Registries of Guarantees of Origin. European experience in the use of GO shows that they can come from an arbitrary place and be «consumed» within one year. The registers are built on the assumption that it is impossible to track the flow of energy. Such a separation of GO with physical reality can reduce consumer confidence [12], which will lead to indifference and a decrease in readiness to pay for tariffs for «green» energy.

Work [13] reports the results of studies of specialized systems that make it possible to account GO. It is shown that such systems are developed as national electronic registers in which GO is traded for each MWh produced, regardless of the place and time of their generation. That is, the issue of taking into account the place and time of electricity production is not resolved. The reason for this is the separation of physical processes from commercial ones. As a result of this approach, utilities can purchase GOs to label non-renewable electricity and sell it as green to their customers [11]. This practice is often criticized as «greenwashing» [13].

Study [11] shows that there are regulatory shortcomings in the regulations both at the national level and at the level of the European Union. Questions remained unresolved regarding the transparency of the process and the fragmentation of workflow, which creates the potential for fraud, for example, double accounting of «green» energy due to improper deletion or cancellation of certificates after use. To overcome the corresponding difficulties, recommendations are made to the developers of regulatory documentation to ensure reliable and sufficient operation of the GO issuance system.

Paper [7] reports the results of studies on the possibility of using GO to determine carbon emissions in accordance with the objectives of the Paris Charter 2022. It is shown that the low discreteness of calculations hinders the identification of consumption over a certain period of time. This is the reason for distorting the picture of the current supply of «green» energy and reducing the accuracy of determining carbon emissions. Consequently, the goal of stimulating the necessary investments is not achieved [11]. An option to overcome the corresponding difficulties may be to increase the discreteness of calculations and take into consideration the loss of electricity for its transmission.

In [14], the results of studies of the compliance of the volumes of «green» energy in the composition of the country's energy balance with its actual consumption by the acquired GO are reported. It is shown that the price and composition of the «mixture» of electricity consumed are the two most important attributes for the consumer. The issue of taking into consideration the place and time of electricity production remained unresolved. Such practices cause significant non-transparency regarding the origin of green energy and may lead to

a discrepancy between the volumes of «green» energy in the country's energy balance and its actual consumption.

One of the approaches to overcoming the corresponding difficulties of GO accounting is considered blockchain technology in various modifications [11, 15]. The main concepts that blockchain operates on are the hash tree (Merkle tree) and the hash root. The validity and expiration date of each GO certificate is easy to verify by knowing the hash root of the Merkle tree without disclosing other properties of the GO certificate [15]. Thus, the authors proposed a compatible, scalable system that prevents fraud or misregistration while maintaining the necessary confidentiality of information for all participants. Such a structure creates a tool for verifying the origin, avoids duplication of certificates.

However, the issue of taking into consideration the place and time of electricity production remained unresolved, that is, the separation of physical processes from commercial ones is used.

It should be noted that according to the regulatory documents regulating approaches to the release of the European Union's GO, taking into consideration physical processes in electrical networks is not mandatory [16]. Therefore, most of the analyzed approaches use simplification, which involves the use of the process of issuing GO precisely as a commercial process not related to power flows and electricity losses [12].

All this suggests that it is expedient to conduct a study aimed at taking into consideration the topology of the network and the place of electricity production in the GO marking system. To do this, it is proposed to improve the model proposed in [15] by taking into consideration physical processes by applying the method of calculating individual components of the flow of RES electricity to an individual subscriber of the distribution system.

---

### 3. The aim and objectives of the study

---

The aim of this study is to improve the mechanisms for labeling guarantees of the origin of electricity by developing and implementing a method for assessing the volume of electricity supply to an individual consumer from renewable sources, taking into consideration their placement and connection to the power grids. Establishing the origin of electricity, taking into consideration physical processes in the electrical network, will help increase consumer confidence in GO certificates.

To accomplish the aim, the following tasks have been set:

- to analyze the means and methods of organizing the work of national electronic registers of GO;
- to devise a method for assessing the volume of power supply to a given consumer from energy sources connected to the electrical network;
- to develop an algorithm for estimating the volume of power supply to a given consumer from renewable energy sources;
- to check the operability of the devised method and the adequacy of the results of assessing the volume of power supply to a given consumer from renewable energy sources.

---

### 4. The study materials and methods

---

The object of this study is the mechanism of labeling guarantees of the origin of electricity in electrical networks with renewable energy sources. The subject of the study are methods and algorithms for confirming the guarantees of the origin of electricity in consumer power supply systems, tak-

ing into consideration their location and connection schemes to distribution power grids.

The application of the research results will contribute to the improvement of the mechanism of labeling of guarantees of the origin of electricity, which will ensure the objectivity of their pricing, as well as the quality of assessing the environmental burden of consumers.

The task of identifying electricity flows belongs to the problems of nonlinear programming. Electricity flows in individual power lines from the generation of RES are non-linear. This complicates the task of isolating individual components from the total flow. Here, it is necessary to take into consideration the voltage drops in the network and the loss of electricity caused by its transportation. The solution to such problems is associated with a number of algorithmic and information issues. To eliminate them, during the formalization of the problem statement, a number of assumptions were used. In particular, it is accepted that the equipment of the electrical network can be equivalent to elements with concentrated parameters. Voltage drops in EN elements are determined by the total flow of electricity at a given point in time, and not by its components. Electricity losses in EN elements from individual transactions are assumed to be proportional to voltage drops and currents caused by these transactions.

To solve the set tasks, generalizing modeling methods, methods of linear and nonlinear programming were used. The steady modes are modeled on the basis of the nodal voltage method. To develop algorithms and a method for estimating the share of electricity consumption of a given consumer, which is provided from renewable energy sources, matrix algebra, graph theory, decomposition and object-oriented analysis were applied.

To conduct the computational experiment, the Mathcad automated design system (USA) was used, the Grafskaner specialized software package (NPC Ukrenergo, Ukraine), as well as our authentic software.

To check the operability of the proposed method and algorithm, a computational experiment was conducted on the example of a 10 kV electrical network of the Joint Stock Company «Vinnitsaoblenergo» (Ukraine). The initial data were obtained from representatives of the energy supply company.

---

## 5. Results of research to determine the volume of guaranteed coverage of the consumer's load with energy from renewable power sources

---

### 5.1. Means and methods of organizing the work of national electronic registers of guarantees of origin

GO are heterogeneous products that differ in the specified characteristics of stations. This leads to the formation of several submarkets with different price levels and market liquidity. The abolition of the Guarantees of origin in the amount of electricity consumption by an individual or enterprises makes it possible to confirm the fact of their consumption of energy from RES. As a commodity certificate, it can also provide manufacturers with additional remuneration. The life cycle of GO is shown in Fig. 1.

An example of data organization in the national register of GO (Fig. 1) is shown in Fig. 2. This technology provides a high degree of transparency in its design and has the ability to bring all parties together on a single neutral platform.

The Merkle tree shown in Fig. 2 is a special data structure that contains summary information about some larger amount of data and is used to verify their integrity [15].

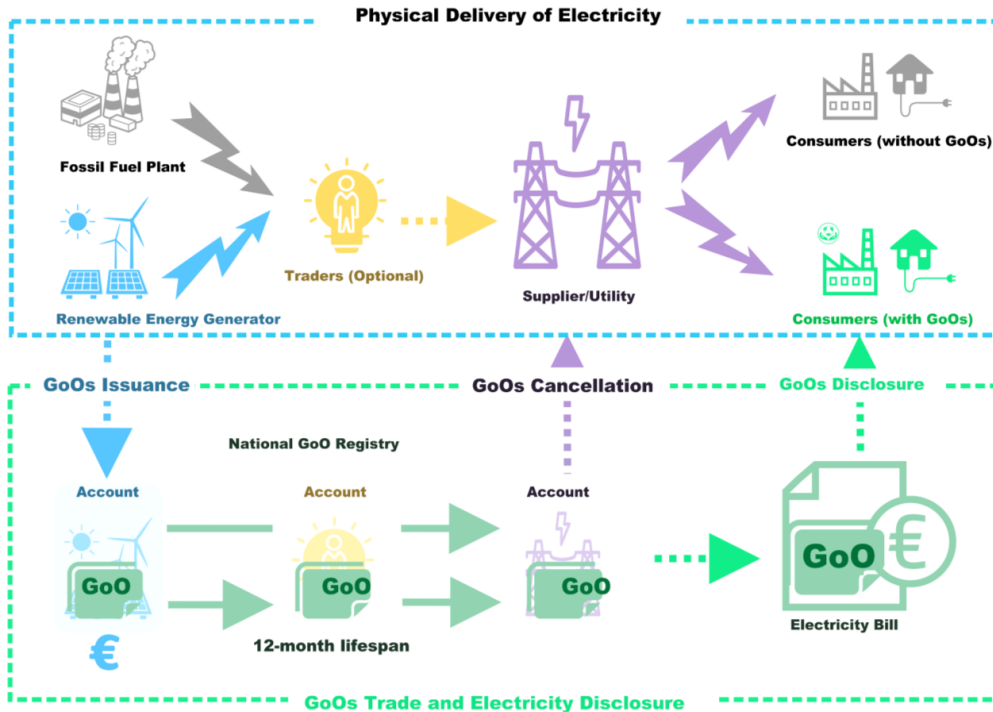

Fig. 1. Life cycle of the Guarantee of Origin

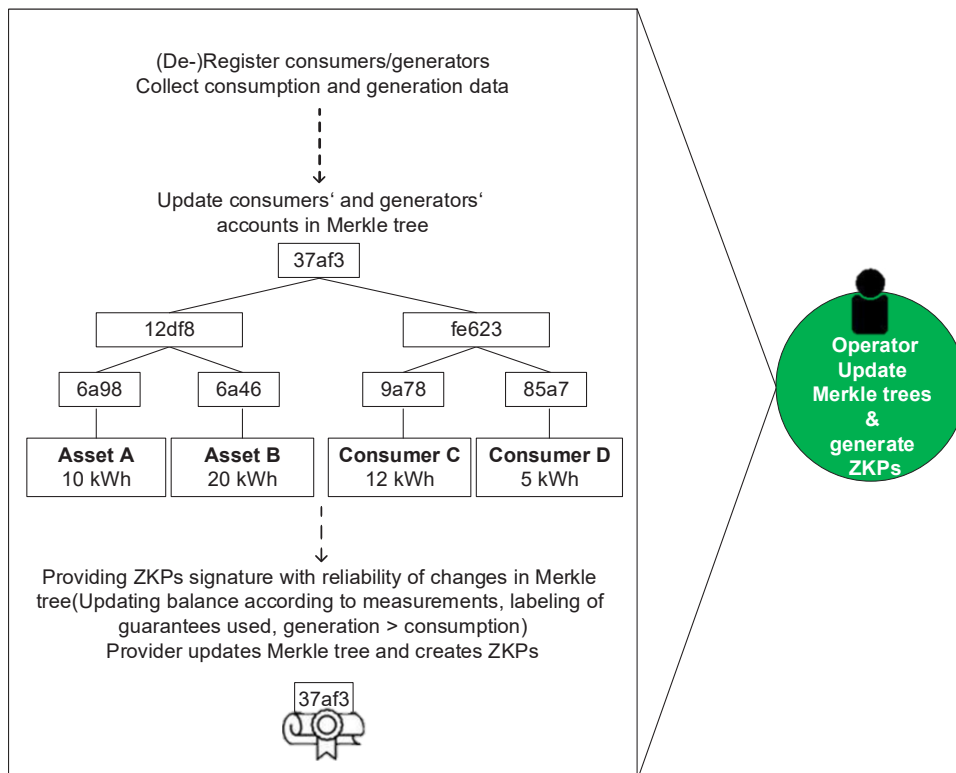

Fig. 2. Organization of data in the register of Guarantees of Origin

Checking the integrity of the data is performed by the GO operator in accordance with the block diagram, which is shown in Fig. 3 [15]. Such a structure makes it possible to label each unit of electricity from RES using blockchain technology and trade these certificates separately from physical energy. In addition, as a modification of the system, it is proposed to use the verification of the authenticity of the hash tree using the zero-knowledge proof method.

The proposed structure of data organization in the labeling system Guarantees of Origin [15] does not provide for taking into consideration the topology of the network and the place of electricity production. Therefore, it is relevant to improve this structure by supplementing the corresponding mathematical apparatus for assessing the share of electricity consumption of a given consumer, which is provided from renewable energy sources.

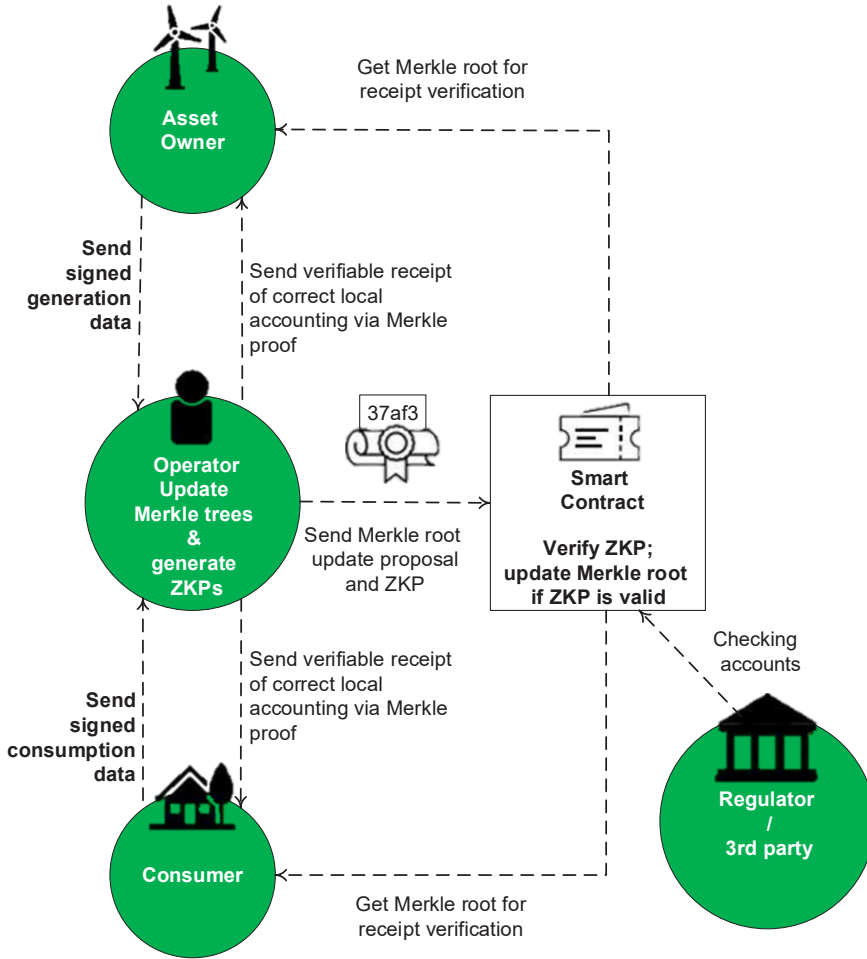

Fig. 3. Generalized structure of the labeling system for Guarantees of origin

## 5. 2. Method for estimating the volume of power supply to a given consumer from available energy sources

To structure power losses in EN for individual electricity transactions taking into consideration nonlinearity, in [17] it is proposed to use a matrix of power loss distribution coefficients in the form of (1):

$$\hat{\mathbf{T}}_i = (\hat{\mathbf{U}}_t \mathbf{M}_{\Sigma i}) \hat{\mathbf{C}}_i \hat{\mathbf{U}}_D^{-1}, \quad (1)$$

where  $\hat{\mathbf{U}}_t$  is the transposed voltage vector in the nodes including basic;  $\mathbf{M}_{\Sigma i}$  –  $i$ -th vector-column of the matrix of incidences;  $\hat{\mathbf{C}}_i$  –  $i$ -th vector-string of the matrix of distribution of currents in the nodes  $\hat{\mathbf{J}}$  along the turns of the circuit of the electrical network with RES;  $\hat{\mathbf{U}}_D^{-1}$  – diagonal inverse matrix of voltages in all nodes including the basic one.

The vector-string  $\hat{\mathbf{T}}_i$  consists of coefficients that show what proportion of the total power losses of the  $i$ -th branch causes the flow of load power (generation) of each node along it.

In expression (1), the first matrix of connections  $\mathbf{M}_{\Sigma}$ , compiled for all nodes of the scheme taking into consideration the basic one, can be represented as the sum of two matrices:

$$\mathbf{M}_{\Sigma} = \mathbf{M}_{\Sigma}^+ + \mathbf{M}_{\Sigma}^-, \quad (2)$$

where  $\mathbf{M}_{\Sigma}^+$  is a matrix containing a fragment of a matrix of connections, the elements of which are zeros and ones with a «+» sign;  $\mathbf{M}_{\Sigma}^-$  – the same matrix, but its elements are zeros and ones with a «-» sign.

To determine the components of power flow in the  $i$ -th line according to the parameters of its end, expression (2) can be represented as:

$$\mathbf{M}_{\Sigma}^k = 0 - \mathbf{M}_{\Sigma}^-. \quad (3)$$

Expression (3) contains a fragment of a matrix of connections whose elements are zeros and ones with a positive sign, which for each line identifies the node of its end. For each node, the matrix makes it possible to define the lines ending in that node.

Power losses according to (1) are defined as the difference between the power flow at the beginning and end of each branch. Thus, after substitution  $\mathbf{M}_{\Sigma}^k$  in (1) instead of  $\mathbf{M}_{\Sigma}$ , an expression was obtained to determine the coefficients of distribution of power flows in the turns of the EN scheme, which are caused by generation in the RES connection nodes:

$$\hat{\mathbf{A}}_i = (\hat{\mathbf{U}}_t \mathbf{M}_{\Sigma i}^k) \hat{\mathbf{C}}_{RESi} \hat{\mathbf{U}}_{RES}^{-1}, \quad (4)$$

where  $\hat{\mathbf{U}}_{RES}^{-1}$  is the inverse diagonal matrix of voltages in the RES connection nodes;  $\hat{\mathbf{C}}_{RESi}$  is the  $i$ -th vector-string of the fragment of the matrix of current distribution coefficients along the turns of the EN circuit, which corresponds to the  $i$ -th node of the RES connection:

$$\hat{\mathbf{C}}_{RES} = \hat{\mathbf{z}}_b^{-1} \mathbf{M}_{RES} (\hat{\mathbf{Y}}_{RES})^{-1}, \quad (5)$$

$\mathbf{M}_{RES}$ ,  $\hat{\mathbf{Y}}_{RES}$  are the fragments of the transposed matrix of connections and the matrix of nodal conductivities of the EN circuit, which correspond to the nodes of the RES connection;  $\hat{\mathbf{z}}_b$  – diagonal matrix of complex resistances of the branches of the electrical network circuit.

Similarly to [3], to determine the flow from RES in the branches of the scheme, one can write:

$$\hat{\mathbf{S}}_{RES}^{flow} = \hat{\mathbf{A}}_i \text{diag}(\hat{\mathbf{S}}_{RES}), \quad (6)$$

where  $\hat{\mathbf{S}}_{RES}^{flow}$  is the vector of power flows in the branches of the circuit caused by generation in the RES connection nodes;  $\hat{\mathbf{S}}_{RES}$  – a fragment of the power vector of EN nodes, which corresponds to the nodes of RES connection.

The vector  $\hat{\mathbf{S}}_{RES}^{flow}$  obtained from expression (6) will contain only the flow in the branches, which are caused by the generation of RES. To determine the flow from other power centers, in particular guaranteed generation power plants, in the  $i$ -th branch of the EN circuit, by analogy with [4], it is proposed to use the expression:

$$\hat{\mathbf{S}}_{PCi}^{flow} = (\hat{\mathbf{U}}_t \mathbf{M}_{\Sigma i}^{end}) \hat{\mathbf{D}}_{PCi} \hat{\mathbf{U}}_{PC}, \quad (7)$$

where  $\hat{\mathbf{D}}_{PCi}$  is the  $i$ -th vector-string of the conductivity matrix, which corresponds to the  $i$ -th branch of the EN

scheme and is determined from the matrix of cumulative conductivities:

$$\dot{\mathbf{D}}_{PC} = \dot{\mathbf{z}}_b^{-1} (\mathbf{M}_{PCt} - \mathbf{M}_{RES} (\dot{\mathbf{Y}}_{RES})^{-1} \dot{\mathbf{Y}}_{PC}), \quad (8)$$

$\mathbf{M}_{PCt}$ ,  $\dot{\mathbf{Y}}_{PC}$  are the fragments of the transposed matrix of connections and the matrix of nodal conductivities of the electrical network circuit, which correspond to the set of nodes of the EN circuit with the exception of the nodes of RES connection. The matrix  $\dot{\mathbf{D}}_{PC}$  has the physical meaning of the conductances that form the currents from the power centers (in particular, the base node) to the consumption nodes.

Taking into consideration (6) and (7), it is possible to write expressions to determine the volumes of guaranteed coverage of the consumer's load with energy from renewable sources and from other power centers:

$$\dot{\mathbf{S}}_{RES}^{vol} = \mathbf{M}_{\Sigma} \dot{\mathbf{S}}_{RES}^{flow}, \quad \dot{\mathbf{S}}_{PC}^{vol} = \mathbf{M}_{\Sigma} \dot{\mathbf{S}}_{PCt}^{flow}. \quad (9)$$

The matrix  $\dot{\mathbf{S}}_{RES}^{vol}$  has a dimensionality in the number of nodes connecting RES and the total number of nodes in the scheme. It accommodates the volumes of guaranteed coverage of the load of individual consumers with energy from certain RES. Taking into consideration the relationship between (6) and (9), the matrix sum of partial volumes  $\dot{\mathbf{S}} = \dot{\mathbf{S}}_{RES}^{vol} + \dot{\mathbf{S}}_{PC}^{vol}$  will always be equal to the total calculated load capacity (generation) in the EN nodes  $\dot{\mathbf{S}}$ .

### 5.3. Algorithm for estimating the volume of power supply to a given consumer from renewable energy sources

Using expression (6) for each line (or set of lines), it is possible to determine its filling with energy from renewable sources and the direction of flow of this energy. Expression (9) provides an assessment of the part of the load of a given node covered by a specific RES, taking into consideration physical processes in the electrical network. Thus, it becomes possible to estimate the volumes of coverage of the load of a given consumer from RES, which transfer energy to the electrical system in a given period of time.

As stated in [15], ZKP can be used to convince the other party of the correctness of a particular mathematical statement without providing any additional information. Applying this to the core context, the use of ZKP seeks to prove the legitimacy of Merkle tree updates for all stakeholders. Thus, by complementing the structures of data organization by taking into consideration physical processes in ZKP, we develop a compatible, scalable system that prevents incorrect accounting while maintaining the necessary confidentiality of information for all participants. This will make it possible to trade certificates taking into consideration physical processes in electrical networks.

To apply the developed method, it is proposed to assign an additional function to the GO operator to determine the volume of guaranteed coverage (Fig. 4). During the formation of ZKP, it is envisaged to use the results of calculating the possible volumes of coverage of the consumer's load according to the algorithm in Fig. 5.

The use of the method to determine the volume of guaranteed coverage of the consumer's load with energy from RES involves the calculation of the EN mode.

In accordance with the above algorithm, the input of the initial data, as well as the formation of specified lists of nodes  $\theta_y$  and branches  $\theta_v$  are brought to the beginning of the algorithm since this stage does not require calculations.

After calculating the steady mode, the formation of the first matrix of connections according to the parameters of its end is provided for all nodes of the circuit  $\mathbf{M}_{\Sigma}^k$  using expression (3), as well as arrays of nodal voltages and the load power vector  $\dot{\mathbf{U}}_t$ ,  $\dot{\mathbf{U}}_{RES}$ ,  $\dot{\mathbf{U}}_{PC}$ ,  $\dot{\mathbf{z}}_b$ ,  $\mathbf{M}_{RES}$ ,  $\mathbf{M}_{PC}$ .

At the next stage of the algorithm, using pre-formed arrays, matrices of nodal conductivities corresponding to nodes with RES and other EN nodes are determined:

$$\dot{\mathbf{Y}}_{RES} = \mathbf{M}_{RES} \dot{\mathbf{z}}_b^{-1} \mathbf{M}_{RES}^t,$$

$$\dot{\mathbf{Y}}_{PC} = \mathbf{M}_{PC} \dot{\mathbf{z}}_b^{-1} \mathbf{M}_{PC}^t.$$

Next, using pre-formed arrays, current distribution matrices are determined, in accordance with (5), and cumulative conductivities  $\dot{\mathbf{D}}_{PC}$ , in accordance with (8).

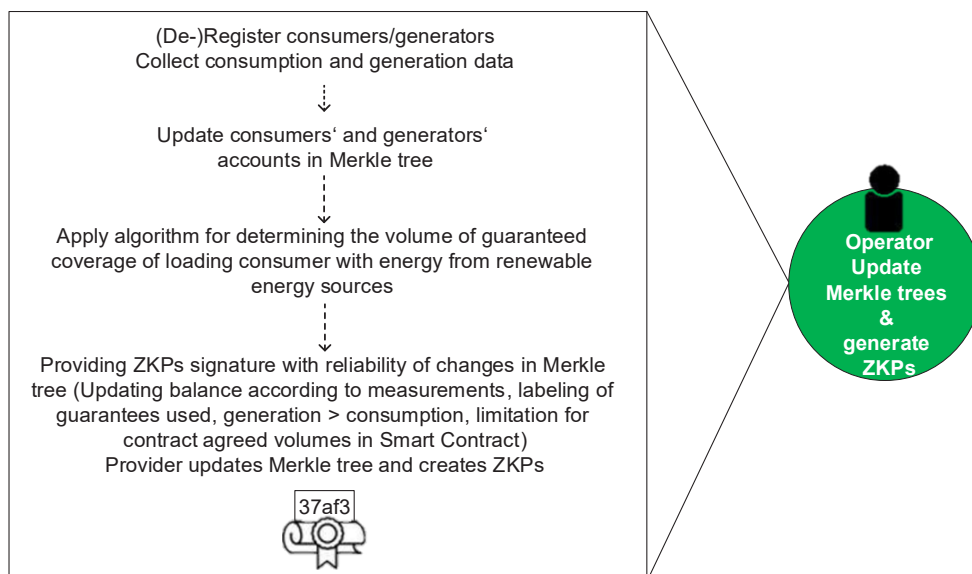

Fig. 4. Organization of data in the register of guarantees of origin, taking into consideration the volume of guaranteed coverage of the consumer's load with energy from renewable energy sources

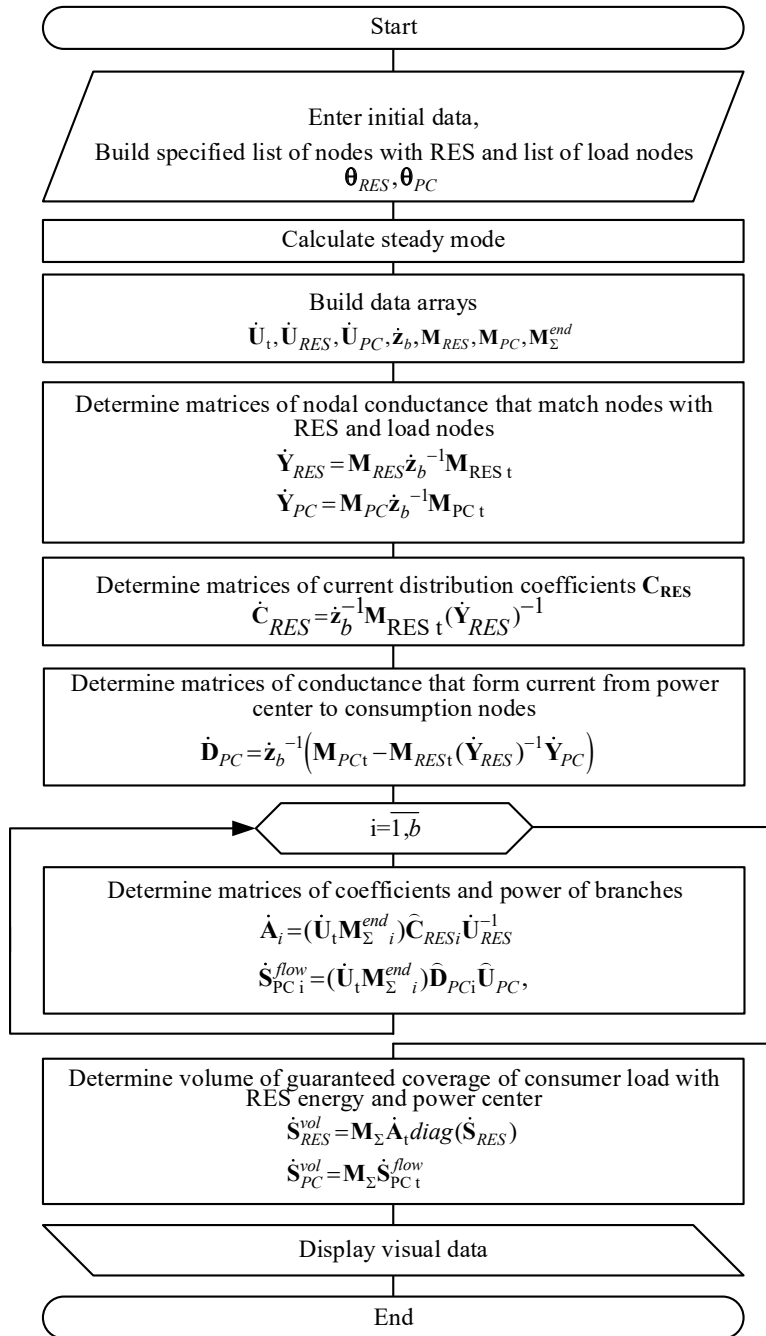

Fig. 5. Algorithm for determining the volume of guaranteed coverage of the consumer's load with energy from renewable power sources

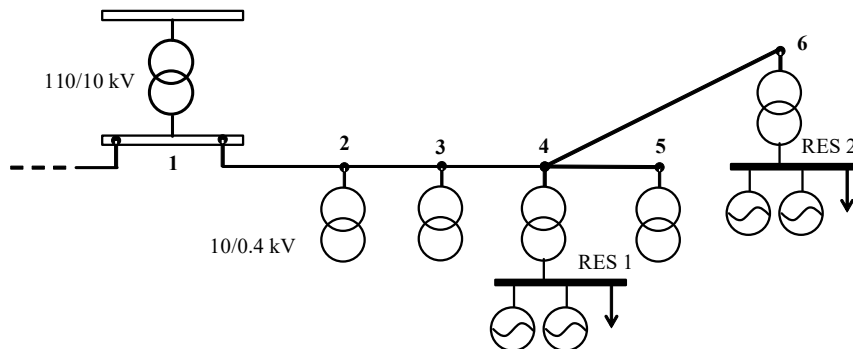

Fig. 6. Diagram of the electrical network 10 kV

The next step of the algorithm, by analogy with [15], involves the step-by-step construction of matrices of power flow distribution coefficients caused by generation in the nodes of RES connection  $A_i$  and flows from the power center to the consumption units  $S_{PC i}^{flow}$ .

The algorithm ends with determining the volume of guaranteed coverage of the consumer's load with energy from renewable power supplies and the power center according to expression (9).

The algorithm is designed to estimate the volume of guaranteed load coverage of a given consumer with energy from RES for electrical networks of arbitrary configuration.

Thus, it makes it possible to assess the qualitative and quantitative possibilities of providing GO that are transparent to end consumers and take into consideration the physical processes in the system of transmission and distribution of electricity.

This will help increase consumer confidence in GO certificates.

#### 5. 4. Checking the operability of the developed method and the adequacy of the results

The adequacy of the method for determining the volume of guaranteed coverage of the consumer's load with energy from renewable sources is shown on the example of a 10 kV electrical network scheme, which is depicted in Fig. 6.

The diagram shows two nodes for connecting RES owned by different business entities, as well as three consumers for which it is necessary to determine the share of electricity covered from RES.

In accordance with the method for determining the share of power in the branches of the electrical network from the generation of RES, we have calculated the steady mode (Tables 1, 2).

Given the results of calculating the steady mode of the electrical network using the software «GrafSkaner» (Ukraine) (Tables 1, 2), the total power flow in the branches of the electrical network corresponds to the total load and generation of RES.

**Table 1**  
Circuit node parameters

No.	$U$ , kV	Phase	$P_{load}$ , MW	$Q_{load}$ , MWr	$P_{gen}$ , MW	$Q_{gen}$ , MWr
1	10.5	0	0	0	1.03	1.29
2	10.426	-0.03	0.4	0.2	0	0
3	10.312	0.02	0.3	0.1	0	0
4	10.178	0.25	0.5	0.3	1	0
5	10.109	0.04	1	0.5	0	0
6	10.177	0.32	0.3	0.15	0.5	0

**Table 2**  
Circuit branch parameters

No.	$No_{end}$	$P^{end}$ , MW	$Q^{end}$ , MW	$dP$ , MW	$I^{begin}$ , kA	$I^{end}$ , kA	$R$ , Ohm	$X$ , Ohm
1	2	-1.02	-1.28	0.007	0.091	0.091	0.27	0.391
2	3	-0.61	-1.07	0.008	0.069	0.069	0.54	0.782
3	4	-0.31	-0.96	0.008	0.057	0.057	0.81	1.173
4	6	0.20	-0.15	0.000	0.014	0.014	0.27	0.391
4	5	-1.00	-0.50	0.005	0.064	0.064	0.405	0.5865

Calculated in accordance with expression (4), the matrix of power flow distribution coefficients in the EN circuits takes the form:

$$\dot{A} = \begin{bmatrix} 0 & 0 \\ 0 & 0 \\ -0.33333 & -0.33333 + j0.00041 \\ 0 & -1 \\ 0.66214 - j0.00243 & 0.6622 - j0.00324 \end{bmatrix}$$

The dimensionality of matrix **A** is determined by the number of nodes with RES and the number of branches  $n$  in the scheme.

The flow of power in the branches of the electrical network circuit, which are caused by generation in the RES connection nodes, are determined from (6):

$$\dot{S}_{RES}^{flow} = \dot{A}_t \text{diag}(\dot{S}_{RES}) = \begin{matrix} \begin{matrix} \text{RES1} & \text{RES2} \\ \text{Node 4} & \text{Node 6} \end{matrix} \\ \begin{bmatrix} 0 & 0 \\ 0 & 0 \\ -0.167 + j0.1 & -0.067 + j0.05 \\ 0 & -0.2 + j0.15 \\ 0.33 - j0.2 & 0.132 - j0.1 \end{bmatrix} \end{matrix} \text{ MW} \begin{matrix} \text{Branch} \\ 1-2 \\ 2-3 \\ 3-4. \\ 4-6 \\ 4-5 \end{matrix}$$

The sum of flows from the main power center, determined from expression (7), and from RES, according to expression (6), determines the total flow in branches:

$$\dot{S}^{flow} = \sum_{j=1..n_{RES}} \dot{S}_{RES_j}^{flow} + \dot{S}_{PC}^{flow} = \begin{bmatrix} 0 & 0 \\ 0 & 0 \\ -0.167 + j0.1 & -0.067 + j0.05 \\ 0 & -0.2 + j0.15 \\ 0.33 - j0.2 & 0.132 - j0.1 \end{bmatrix} + \begin{bmatrix} 1.022 + j1.268 \\ 0.622 + j1.074 \\ 0.532 + j0.807 \\ 0 \\ 0.531 + j0.799 \end{bmatrix} = \begin{bmatrix} 1.022 + j1.268 \\ 0.622 + j1.074 \\ 0.299 + j0.957 \\ -0.2 + j0.15 \\ 0.994 + j0.5 \end{bmatrix} \text{ MW} \begin{matrix} 1-2 \\ 2-3 \\ 3-4. \\ 4-6 \\ 4-5 \end{matrix}$$

Using expression (9), we obtain the volumes of coverage of the load of each consumer with electricity from RES (taking into consideration losses in the transmission of electricity) in accordance with Table 3.

**Table 3**  
Volumes of coverage of the load of a given consumer with electricity from RES

Node No.	$P_{PC}$ , MW	$P_{RES1}$ (4), MW	$P_{RES2}$ (6), MW	$P_{load}$ , MW
2	0.4	0	0	-0.4
3	0.066	0.167	0.067	-0.3
4	0	-0.5	0	0.5
5	0.531	0.33	0.132	-1
6	0	0	-0.2	0.2

Since to date there is no industrial software that makes it possible to determine the volume of coverage of the load of a given consumer with electricity from RES, it is possible to evaluate the effectiveness of the calculation results indirectly by comparing the data in Tables 2, 3. From the calculation results, it is clear that the sum of the volumes of electricity coverage from RES and power centers coincide with the parameters of the EN mode used in the calculation applying the industrial software «GrafSkaner» (Ukraine). Thus, on the basis of the proposed method, an algorithm for issuing GO, justified from the point of view of electrical engineering, can be developed. It can be used to determine the volume of receipts from the sale of Guarantees and send them to the transmission system operator or the Guaranteed Buyer as additional financial support.

**6. Discussion of results of investigating the mechanism for confirming the guarantees of origin**

The structure of the data organization in the register of guarantees of origin is based on blocks that are already productively used in decentralized finance, for example, in the form of ZKP [15].

Analysis of sources to compare the results obtained with the achievements of other scientists in this area showed [18] that in all European countries the separation of physical processes from commercial ones is used, therefore, taking into consideration the topology of the network and the loss of electricity for its transmission in (9) is an absolute advantage of our study.

Most European experts agree that the best approach to taking into consideration electricity losses is to require a responsible TSO (and/or DSO) to compensate for losses in the network by canceling the proper number of GO and removing them from the market [19]. Such a mechanism can be implemented using the developed method because the volume of power supply to the consumer from renewable sources is determined from (6) to (9) excluding targeted electricity losses.

The addition of the structure, proposed in [15], for the organization of data of the register of guarantees of origin justified from the point of view of electrical engineering algorithm for the release of GO (Fig. 5) will limit the volume of their purchase by individual consumers. A consumer connected to the power grid with



an excess of RES will not have restrictions on the purchase of GO if the schedule of its power consumption partially or fully corresponds to the schedule of operation of RES power plants. Under other conditions, objective restrictions are imposed on the acquisition of GO. After all, electricity produced from RES is consumed at the time of its production by a certain circle of consumers with a corresponding reduction in carbon emissions. This approach is a tool for confirming the guarantees of the origin of energy sold in the retail market. This makes it impossible to double-account for green energy and creates transparent conditions for issuing certificates, as well as accurately reflects carbon emissions.

The use of the proposed method (6) to (9) requires additional calculations, which can somewhat slow down the process of issuing GO. To reduce the volume of calculations, it is advisable to use certain simplifications by applying typical modes of operation of the electrical network and the transition from the method of numerical integration to the method of average loads.

Based on the research, a method and algorithm for determining the proportion of power flows to a certain load node from a set of renewable energy sources, which has certain advantages, were proposed.

The total volumes of GO that the consumer can purchase are proposed to be determined taking into consideration the parameters of the mode and physical processes in electrical networks. This makes it possible to take into consideration the loss of electrical energy for its transmission (9) and more accurately take into consideration carbon emissions.

Practical calculations (Tables 1–3) showed the effectiveness of the method and algorithm. The adequacy of the obtained results is confirmed by the compliance of the total values of partial flows and consumption particles in the nodes with flows in the branches and loads determined from the results of the calculation of the normal mode of the electrical network.

The disadvantages of using the proposed mechanism are the need to ensure high throughput of electricity metering, close to real time. Each individual consumer will need a transaction every 15 minutes. It also creates additional requirements for computing technology and data organization in the GO system. In addition, it is necessary to take into consideration error handling issues, for example, in the event of a delay in the transmission of meter readings.

This study may be advanced by the formation of stable dependences between the parameters of the regime and the volume of distribution of GO for characteristic modes. This will reduce the computational load and simplify the process of determining the possible volumes of GO for each consumer.

---

## 7. Conclusions

---

1. Existing approaches to the organization of work of national electronic registers of GO do not provide for

taking into consideration the topology of the network and the place of electricity production. Registers are organized on the principles of separation of physical processes from commercial ones. Therefore, it is relevant to supplement the existing structure of the GO organization by taking into consideration physical processes in the transmission and distribution systems of electricity, which requires the development of an appropriate mathematical apparatus.

2. A method has been developed that makes it possible to isolate a component from the flow of energy in each transmission, which is due to a separate connected energy source. This makes it possible to determine the load fraction of each node of the electrical network supplied by a specific source of electricity. The nonlinearity of the ratio between the voltages in the nodes and the capacities in the EN branches is taken into consideration by the piecewise-linear approximation for the results of the calculation of the steady modes. To estimate the volume of coverage of the load of a given consumer from renewable energy sources, the results of structuring power flows to the node of its connection by sources of origin are used. The proposed method can be a tool for confirming the guarantees of the origin of energy sold in the retail market.

3. An algorithm for determining the volume of guaranteed coverage of the consumer's load with energy from renewable power sources has been developed. It takes into consideration not only indicators of the balance of electricity but also the results of assessing the volume of electricity supply to each consumer from renewable sources. Using this algorithm, the possibilities of providing GO for each energy consumer can be quantified. Such assessments are transparent to end users, they take into consideration physical processes in the electrical system, which will increase consumer confidence in GO certificates.

4. For a 10 kV electrical network, the volumes of coverage of the load of a given consumer with electricity from RES were determined. It is shown that depending on the scheme of connection of the consumer and RES, the share of its consumption covered with RES will be different. It was established that the parameters of the EN mode, calculated according to the industrial software, and the parameters of the mode determined by the proposed method, practically coincide.

---

## Conflict of interests

---

The authors declare that they have no conflict of interest in relation to this research, whether financial, personal, authorship or otherwise, that could affect the research and its results presented in this paper.

---

## References

1. Kotilainen, K., Valta, J., Makinen, S. J., Jarventausta, P. (2017). Understanding consumers' renewable energy behaviour beyond «homo economicus»: An exploratory survey in four European countries. 2017 14<sup>th</sup> International Conference on the European Energy Market (EEM). doi: <https://doi.org/10.1109/eem.2017.7981932>
2. Scheller, F., Graupner, S., Edwards, J., Weinand, J., Bruckner, T. (2022). Competent, trustworthy, and likeable? Exploring which peers influence photovoltaic adoption in Germany. *Energy Research & Social Science*, 91, 102755. doi: <https://doi.org/10.1016/j.erss.2022.102755>
3. Lehne, J., Sartor, O. (2020). Navigating The Politics Of Border Carbon Adjustments. E3G. Available at: [https://www.e3g.org/wp-content/uploads/E3G-Briefing\\_Politics\\_Border\\_Carbon\\_Adjustment.pdf](https://www.e3g.org/wp-content/uploads/E3G-Briefing_Politics_Border_Carbon_Adjustment.pdf)

4. Hansen, K., Breyer, C., Lund, H. (2019). Status and perspectives on 100 % renewable energy systems. *Energy*, 175, 471–480. doi: <https://doi.org/10.1016/j.energy.2019.03.092>
5. van Renssen, S. (2020). The hydrogen solution? *Nature Climate Change*, 10 (9), 799–801. doi: <https://doi.org/10.1038/s41558-020-0891-0>
6. Fridgen, G., Keller, R., Körner, M.-F., Schöpf, M. (2020). A holistic view on sector coupling. *Energy Policy*, 147, 111913. doi: <https://doi.org/10.1016/j.enpol.2020.111913>
7. de Chalendar, J. A., Benson, S. M. (2019). Why 100 % Renewable Energy Is Not Enough. *Joule*, 3 (6), 1389–1393. doi: <https://doi.org/10.1016/j.joule.2019.05.002>
8. Comello, S., Reichelstein, J., Reichelstein, S. (2021). Corporate Carbon Reduction Pledges: An Effective Tool to Mitigate Climate Change? *SSRN Electronic Journal*. doi: <https://doi.org/10.2139/ssrn.3875343>
9. Flood, C. (2021). Heavyweight investors demand more disclosure of environmental risks. *Financial Times*. Available at: <https://www.ft.com/content/7d23ef7f-33ba-4466-b2f1-2a5dfeba1e33>
10. Heffron, R. J. (2021). Energy multinationals challenged by the growth of human rights. *Nature Energy*, 6 (9), 849–851. doi: <https://doi.org/10.1038/s41560-021-00906-6>
11. Bogensperger, A., Zeiselmaier, A. (2020). Updating renewable energy certificate markets via integration of smart meter data, improved time resolution and spatial optimization. 2020 17th International Conference on the European Energy Market (EEM). doi: <https://doi.org/10.1109/eem49802.2020.9221947>
12. Hamburger, Á. (2019). Is guarantee of origin really an effective energy policy tool in Europe? A critical approach. *Society and Economy*, 41 (4), 487–507. doi: <https://doi.org/10.1556/204.2019.41.4.6>
13. Will, C., Jochem, P., Fichtner, W. (2017). Defining a day-ahead spot market for unbundled time-specific renewable energy certificates. 2017 14th International Conference on the European Energy Market (EEM). doi: <https://doi.org/10.1109/eem.2017.7981967>
14. Kaenzig, J., Heinze, S. L., Wüstenhagen, R. (2013). Whatever the customer wants, the customer gets? Exploring the gap between consumer preferences and default electricity products in Germany. *Energy Policy*, 53, 311–322. doi: <https://doi.org/10.1016/j.enpol.2012.10.061>
15. Sedlmeir, J., Völter, F., Strüker, J. (2021). The next stage of green electricity labeling. *ACM SIGEnergy Energy Informatics Review*, 1 (1), 20–31. doi: <https://doi.org/10.1145/3508467.3508470>
16. Directive (EU) 2018/2001 of the European Parliament and of the Council. (2018). Available at: [https://eur-lex.europa.eu/legal-content/EN/TXT/?uri=uriserv:OJ.L\\_.2018.328.01.0082.01.ENG](https://eur-lex.europa.eu/legal-content/EN/TXT/?uri=uriserv:OJ.L_.2018.328.01.0082.01.ENG)
17. Abenov, A., Lezhnjuk, P. D., Kulik, V. V., Burykin, O. B., Malogulko, J. V., Kacejko, P. (2018). Transmission loss allocation for a bilateral contract in deregulated electricity market. *Photonics Applications in Astronomy, Communications, Industry, and High-Energy Physics Experiments 2018*. doi: <https://doi.org/10.1117/12.2501604>
18. Draeck, M., Timpe, C., Jansen, J., Schoots, K., Lescot, D. (2009). The state of implementation of electricity disclosure and guarantees of origin across Europe. 2009 6<sup>th</sup> International Conference on the European Energy Market. doi: <https://doi.org/10.1109/eem.2009.5311433>
19. European Union's Horizon 2020 research and innovation programme under grant agreement No. 734137. (2020). CORE THEME 3: Guarantees of Origin and Disclosure. Available at: [https://www.ca-res.eu/fileadmin/cares/PublicArea/CA-RES3Final-Publication/CARES3\\_Final\\_CT3\\_Summary.pdf](https://www.ca-res.eu/fileadmin/cares/PublicArea/CA-RES3Final-Publication/CARES3_Final_CT3_Summary.pdf) Last accessed: 28.09.2022