

*The quality of mechanical processing of the skin largely depends on the parameters of the skin feeding to the processing zone between the working rolls. The processed material at the entrance to the processing zone must be free of folds and wrinkles, i.e. one layer of material should enter the processing zone of the working rolls. Therefore, the input of the processed material into the zone of the working rolls is ensured with a rational selection of the profile of the guiding device for feeding the skin into the processing zone. A mathematical model was developed that allows the authors to determine the profile of the guiding device for leather feeding into the processing area between the working rollers, considering the modulus of elasticity and the density of the material being processed. The graphical solution to the mathematical model of the guiding device profile was made by a numerical method, and in order to prevent the leather saturated with liquid from sticking to the guiding surface, the friction coefficient was replaced with the rolling friction coefficient, and the rollers of the guiding device were placed at a certain angle to level out the folds of the leather and smoothly feed it to the processing area. A new design of roller technological machines was manufactured in laboratory settings. The roller machine is equipped with a new guiding device using rollers, with the possibility of free rotation around its axis. The rollers can be placed in several rows in a staggered arrangement. The developed design of the guiding device, due to the installation of the rollers at a certain angle relative to the direction of skin feed, makes it possible to smoothly transport the treated skin while eliminating longitudinal and transverse folds. The elimination of wrinkles contributed to an increase in the usable area of the treated leather samples. Experimental and testing work was conducted on a roller squeezing machine for processing leather samples using a new design of guiding device. The working width of the guiding device was 1500 mm, and the rollers of a diameter of 30 mm, allowed the straightening of the folds of the leather and moving it to the gripping zone of the working rollers. In the experimental study, the second-order D-optimal planning method was used with the Kano design matrix*

**Keywords:** roller machine, conveying device, working rolls, leather squeezing, straightening rollers

UDC 675.055

DOI: 10.15587/1729-4061.2023.277393

# DETERMINATION OF RATIONAL PARAMETERS OF A DEVICE FOR LEATHER FEEDING TO THE MACHINING AREA

**Gayrat Bahadirov**

Doctor of Technical Sciences, Professor\*

**Makhmarajab Musirov**

Corresponding author

PhD

Department of Applied Mechanics

Tashkent State Transport University

Temiryulchilar str., 1, Tashkent,

Uzbekistan, 100167

E-mail: musirov.mech.1992@mail.ru

**Ayder Nabiev**

PhD

Research Laboratory\*

\*Department of Theory

of Mechanisms and Machines

Institute of Mechanics and Seismic Stability

of Structures of the Academy of Sciences

of the Republic of Uzbekistan

Durmen yuli str., 33, Tashkent,

Uzbekistan, 100125

Received date 07.02.2023

Accepted date 11.04.2023

Published date 28.04.2023

**How to Cite:** Bahadirov, G., Musirov, M., Nabiev, A. (2023). Determination of rational parameters of a device for leather feeding to the machining area. *Eastern-European Journal of Enterprise Technologies*, 2 (1 (122)), 62–72. doi: <https://doi.org/10.15587/1729-4061.2023.277393>

## 1. Introduction

In the conditions of innovative development of the country's economy, leather and footwear enterprises face problems, the solution of which is associated with the development of new technologies and equipment, and with an increase in the efficiency of scientific research. A promising direction for the innovative development of the leather and footwear industry is the improvement and renewal of technologies and equipment for the production of leather.

The current trend in the development and improvement of the main devices and mechanisms of roller technological machines for the mechanical processing of leather semi-finished products in the leather industry shows that, at present, most of the large leather enterprises switch to the use of small-sized, compact, and mobile technological machines,

which improve the quality of finished leather, create additional opportunities for reorientation in accordance with the requirements of the national economy. Recently, scientists have been developing improved designs of roller technological machines to conduct the technological process of mechanically squeezing excess moisture, that is, to process the leather under the pressure of squeezing rollers. To prove the advantages of these developments, they must be scientifically substantiated by theoretical and experimental studies.

To improve the designs of existing technological machines for leather production, it is necessary to develop new technical solutions and processing methods based on modern production requirements. The new designs of technological machines developed by scientists should have social and economic efficiency and help improve working conditions for personnel. Recently, a trend has been established

for the development of «green technologies» in all sectors of the economy.

To scientifically substantiate the parameters of newly developed technological machines, engineers, designers, and scientists should improve their calculation and design methods. In addition, for the practical substantiation of the parameters of improved machines, laboratory, experimental, and production tests should be conducted.

Currently, more attention is paid to the preservation of natural properties and quality indicators in the process of finishing raw hides. To get finished leather, the raw material goes through numerous chemical and mechanical processes. Since the physical and mechanical properties of different types of raw hides differ significantly, the requirements for their processing can also vary significantly. Many technological machines for processing leather raw materials have complex designs and high metal consumption. Consequently, there are certain difficulties in the maintenance of these machines. When creating machines of a simplified design, it is necessary to ensure the technological continuity of their main parts and assemblies. Therefore, studies devoted to the creation of technological machines with a simplified design and easy technical maintenance are of scientific relevance.

---

## 2. Literature review and problem statement

---

At present, roller technological machines are widely used in many areas of production, including the machining of leather. Among these processes, the uniform feed of leather to the gripping zone of the working rollers is of particular importance since it increases the useful area of leather

However, in addition to a number of advantages in the mechanical processing of leather with roller technological machines, there are several disadvantages that do not meet modern technological requirements. These shortcomings are manifested in the low quality of manufactured products. They include low labor productivity, high consumption of metal and other materials in the manufacture of technological machines, high energy consumption during their operation, and low performance and service life of machine parts. These shortcomings are mainly due to the fact that their kinematic, dynamic, and technological indices are not scientifically substantiated when designing and researching new machines. One of these aspects is the mathematical modeling of the treating process and technological machine, considering the physical, mechanical, and other properties of the processed product [1].

It is known [2] that the feed of the processed material to the processing zone of the roll pair without folds and wrinkles is an important task in various industries because this leads to the elimination of defects and losses of the resulting finished product. This paper describes in detail the mechanical processing of raw hides. The device and principles of operation of various technological machines are also given. To improve the design of roller machines, the existing shortcomings in the design of squeezing machines are described (the non-uniform removal of fluid over the entire area of the hide and others).

Consequently, the implementation of such measures in the production of leather ultimately leads to a significant saving of raw materials [3].

In [4], the authors investigated the conditions for ensuring the free slip of homogeneous bodies in a curved cylinder.

The value of the curvature of the curved cylinder was determined to ensure the free slip of the body along it. However, the study does not take into account the longitudinal and transverse forces of a homogeneous body flattening along a curvilinear cylinder.

The influence of the curvature of a curved surface on the slip of rocks with friction was studied in [5]. The authors used the methods of two-dimensional boundary elements and rock fracture mechanics to determine the effect of the curvature of a curved surface on its slip. However, in this study, the elastic property of the rock moving along the curved surface is not considered.

In [6] the conditions for vertical transportation of the skin to the treatment area were studied. The conditions for capturing the skin by rotating working shafts in the zones of initial contact, the setting process, and the exit from contact are determined. Analytical formulas have been obtained for each zone of contact between the skin and the working rollers. However, since, in this paper, the conveying process under consideration is carried out in the vertical direction, there is no transition zone here. Therefore, for this it is necessary to consider and solve the problem of ensuring the straightening of the folds of leather supplied for machining between rotating working rolls.

The authors of [7] studied the condition of a viscous fluid flow over a curved surface with slip. The energy equation of the effect of an electrically conducting liquid was modeled. In this study, the equations of motion of elastoplastic materials along a curved surface were not compiled.

In [8], the flow of a nanofluid along a curved sheet was studied. The curvature parameters of a conveying curved sheet were studied considering the viscosity of the nanofluid. Internal forces of nanofluids were not taken into account in this article in determining the geometric parameters of a curved surface.

Problems of a slip flow conditions in a curvilinear channel consisting of two cylindrical surfaces were studied in [9]. The authors of the article considered two particular cases of flow slip: under rotation of a cylindrical surface, and at its stationary-state position. The main velocity profiles were obtained for both cases of sliding flow. The problem of linear instability of a sliding flow was solved by a numerical method.

Dependences of the critical values of the slip flow instability criteria on the ratio of the radii of the concave and convex walls and on the velocity slip factor were determined. In [10], the authors proposed an innovative model of a vacuum device to improve reliability and provide piece-by-piece capture from a stack of leather layers by suction. The device also moves the stack of leather layers to the section of their further splitting. There, the problem of transporting a moisture-saturated material between cylindrical rolls without the participation of maintenance personnel was not solved.

An assessment of a new stable continuous system for the processing of bovine leather was given in [11]. In this study, the effect of change in the properties, types, and parameters of raw hides on the continuity of operation was not established.

Using the prototype [12], the process of dehydration of bovine hides is performed. This new process results in dehydrated leather with optimal physical and chemical characteristics that make it possible to be tanned by immersion in aqueous chemical solutions. However, when removing fluid from the hides, folding the layers of raw hides between the squeezing rolls results in more waste.

Today, environmentally friendly «green leather, fur» has begun to develop in line with environmental concerns, using chromium since the use of heavy metals should be limited and emission standards should be met. Every country has different wastewater regulations. According to the standards adopted in developing countries, emissions of chromium III valence are from 1.5 to 5 mg/l and emissions of chromium VI valence are from 0.1 to 0.5 mg/l or 0 mg/l on leather. Chrome-plated leather and fur contain a valence III tanning agent that is slightly toxic, so its use is still permitted. However, liquid runoff and solid waste should be handled in accordance with existing laws and regulations [13]. The treatment, storage, and disposal of wastewater and sludge is a major challenge. There are different approaches, such as the improvement of tanning parameters, modification of tanning agents or collagen, and the use of auxiliary agents or combined tanning agents to prevent these technical and environmental problems caused by traditional tanning. Today, the extraction of chromium oxides from the waste of leather production is very relevant. Therefore, it is necessary to switch to waste-free technologies for leather production.

Let's consider some studies devoted to solving the above problems and issues. For example, tanning leads to significant contamination of wastewater with chromium and chlorides. A new method of tanning leather without flotation and with a minimum salt content was developed. Besides, during tanning, the amount of chromium salts is significantly reduced [14].

This leather tanning technology is relevant in terms of reducing wastewater pollution, and protecting the environment.

Further, new promising technologies and methods of leather tanning are considered, which are gradually being introduced into the production standards of the leather industry.

The authors of [15] synthesized a pre-tanning agent for leather. The agent for initial tanning reacts with collagens and improves the hydrothermal properties of leather.

The authors of [16] synthesized and developed a new material based on collagen fibers with high adsorption of chromium salts as a modifying agent. The resulting material has a high hydrothermal property compared to traditional tanning methods.

In [17], the problems of tanning skins, and the issues related to the disposal of various wastes are considered. A detailed review and analysis of the state of these problems, especially in large enterprises, are presented. Some solutions were proposed to mitigate environmental impact and reduce leather waste.

The study in [18] is devoted to the development of environmentally friendly tannin salt. The results of the study showed the high technical and economic efficiency of this development. Thus, the chrome tanning process was developed.

The current state of roller technological machines in the leather industry and the analysis of scientific research to improve their productivity, the quality of the processed leather and the increase in its usable area make it possible to conduct targeted studies of technological processes occurring in leather machining.

The authors have developed a device that increases the technological capabilities of the roller machine. This device provides a smooth supply of sheet material to the processing zone without wrinkles and folds, by reducing the friction force of rubbing surfaces [19].

The influence of the feed rate, and the pressing force of the squeezing rollers on the amount of moisture extracted from two layers of the semi-finished leather product after their

squeezing was experimentally determined in [20]. It is also shown that due to the flexibility of the monshon (moisture-wicking cloth), the passage of the semi-finished leather product along the conveying device is shortened. However, in this study, the problem when the feed rate of raw hides differs from the velocity of the working rolls was not solved; in the processing zone the fibers of the raw hides break.

The forces acting in the process of feeding a leather semi-finished product into the working area of a multi-operational machine were studied. Analytical expressions were derived to determine the rational parameters of the mechanism for supplying a semi-finished leather product to the processing zone [21]. In this study, when determining the expressions for the forces acting on the working area, in addition to the friction coefficient, the viscosity coefficient was not taken into account.

In [22], a roller device was developed for squeezing moisture-saturated skins. The process of pressing the skins was conducted in a vertical direction. A chain drive and base plates were used as a conveyor.

However, along with certain advantages, this device also has design flaws. For example, compared to known squeezing machines with one flattening roll, here it is necessary to install two flattening rolls. Obviously, the design of such a machine, due to its greater material consumption, is more complicated.

In [23], based on known rheological and mechanical models, an improved rheological model of skin was developed. For the first time, the use of the property of the inert resistance of the skin during its deformation, for example, during mechanical squeezing, was proposed in the model.

However, this rheological model could be applied to finished leather only. Since the physical and mechanical properties of raw hides and finished leathers differ significantly, this model is not suitable for application to raw hides. Therefore, it needs to be improved taking into account the physical and mechanical properties and characteristics of the semi-finished leather product.

Based on the analysis of existing studies and equipment, we have determined the development trend of theoretical and practical foundations for improving the actuators and devices of roller technological machines for leather production.

Based on the study and analysis of the operation of existing technological machines for processing leather, the following was revealed. In these technological machines, an additional flattening roll with a separate drive was used to straighten various folds of leather. This, in turn, requires additional material and energy costs since the manufacture of a flattening roll is a complex process and requires modern equipment.

In order to simplify the design of the roller squeezing machine, we have developed a conveying device for supplying processed skins. Wet raw hides are subjected to mechanical deformation in the zone of excess fluid squeezing out under the pressure of rotating working rolls. At the same time, due to the use of a roller guide device in the design of the machine, skin folds are straightened. Due to the design features and location of the rollers, the useful area of the skin increases, as well as the productivity of the technological process increases.

This paper presents the results of theoretical and experimental studies to substantiate the effectiveness of the guiding device of the roller squeezing machine proposed by the authors.

### 3. The aim and objectives of the study

The main aim of this study is to determine the rational design, geometric, and technological parameters of the guiding device, which makes it possible to improve the possibilities of the operations performed when transporting and squeezing excess fluid from wet leather.

To achieve the aim of the study, it is necessary to solve a number of the following main tasks:

- to obtain analytical expressions that allow calculating the parameters of the profile of the guiding device of the roller technological machine for squeezing moisture-saturated leather;
- to determine the geometrical parameters of the guiding device depending on the values of the working width of the passage of the roller squeezing machine, which depends on the type of processed leather;
- to experimentally determine and scientifically substantiate the parameters of the guiding device. At the same time, to determine rational feed rates, roller pressures, and the ability to straighten the folds of the processed skins.

### 4. Materials and methods

When developing a guide-correcting device, it is necessary to take into account the factors that affect the operation of the device and the technological process of supplying the processed material in a single layer. The main influencing factors on the operation of the device are the geometric parameters of the device, profile (trajectory), feed rate, modulus of elasticity, density, internal and external forces acting on the material being processed, coefficients and forces of friction of rubbing pairs. The scientific substantiation of the parameters of the guiding-correcting device, taking into account the above factors, will improve the quality of material feeding and the yield of the usable area of the processed hides.

By means of the guide-and-straightening device developed by the authors, which moves the leather into the machining zone, the technological process was conducted at a certain ratio between the feed rate of the conveyor and retraction by the working rollers (Fig. 1). In the known devices, a uniform feed of leather to the processing zone between the rollers is not ensured, and this indicates that the treatment process cannot be performed in the required quality.

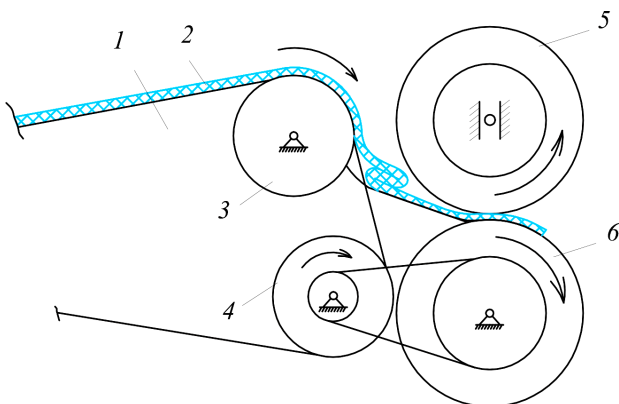

Fig. 1. Folding of leather during conveying to the processing area: 1 – conveyor; 2 – leather; 3, 4 – conveyor rollers; 5, 6 – squeezing rollers

Let's consider a section of leather shown in Fig. 2 and derive an equation of motion, taking into account the internal and external forces acting on it. From Fig. 2 it can be seen that this selected section slides at a constant velocity along a curved surface under external and internal forces acting on it, namely, gravity, friction, and internal stresses.

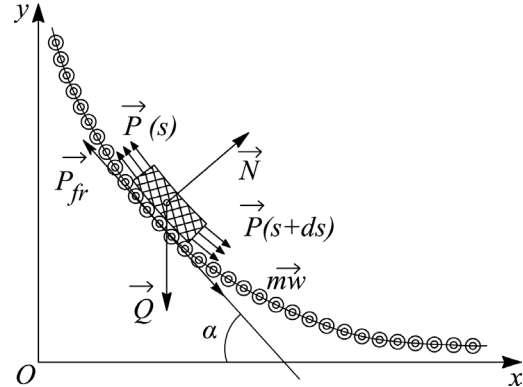

Fig. 2. The system of forces acting on a selected section of leather

All external and internal forces acting on the selected section of leather are written in the following form (Fig. 2):

$$\rho \bar{v} ds = (\bar{P}(s+ds) - \bar{P}(s)) + \bar{N} ds + \bar{P}_f ds + \bar{Q} ds, \quad (1)$$

here,  $\bar{P}(s)$  is the internal stress of the selected section of leather, distributed over distance  $s$ ;  $\bar{P}(s+ds)$  is the internal stress of the selected section of leather, distributed over distance  $s+ds$ ;  $\bar{N}$  is the force of the normal response of the selected section of leather;  $P_{fr}$  is the friction force arising from the movement of a selected section of leather along the rolls;  $\bar{Q}$  is the force of gravity of the selected section of leather.

To determine the trajectory of the selected section of leather along rollers, we project equation (1) onto tangential  $\bar{\tau}$  and normal  $\bar{n}$  axes and taking into account that Hooke's law  $P = E \frac{dy}{dx}$  and Cauchy's law  $\frac{dP}{dx} = E \frac{d^2y}{dx^2}$  are equal, we write the following:

$$\bar{\tau} : \rho ds \frac{dv}{dt} = E \frac{d^2y}{dx^2} - P_{fr} ds + \rho g ds \sin \alpha, \quad (2)$$

$$\bar{n} : \rho ds \frac{v^2}{R} = N ds - \rho g ds \cos \alpha. \quad (3)$$

From equation (2) we determine the rolling friction force  $P_{fr}$ :

$$P_{fr} = \frac{\delta}{r} N. \quad (4)$$

The sliding and rolling forces must meet the following condition:

$$F_{fr} > P_{fr}. \quad (5)$$

From inequality (5) it was determined that the following condition is satisfied for the sliding and rolling friction coefficients:

$$f > \frac{\delta}{r}. \quad (6)$$

Here,  $f$  is the coefficient of sliding friction of the selected section of leather along the rollers,  $\Delta$  is the coefficient of rolling friction of the rollers, and  $r$  is the radius of the rollers.

Fig. 3 shows a conveying device consisting of driving (6) and driven (7) rollers, with upper (2) and lower (3) working rolls located one above the other, with the possibility of moving around the upper working roll from/relative to the guiding device in the leather feed direction (5). Fig. 4 shows a diagram of an improved device for guiding leather.

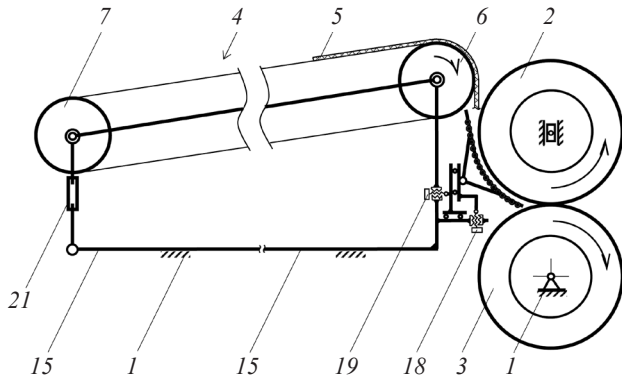

Fig. 3. Scheme of a conveyor with a leather guiding device into the processing area between the rotating rollers: 1 – bed; 2 – upper roller; 3 – lower roller; 4 – string conveyor; 5 – sheet material (leather); 6, 7 – conveyor rollers; 15 – conveyor frame; 18 – inclination regulator of the guiding device; 19 – height regulator of the guiding device; 21 – string conveyor regulator

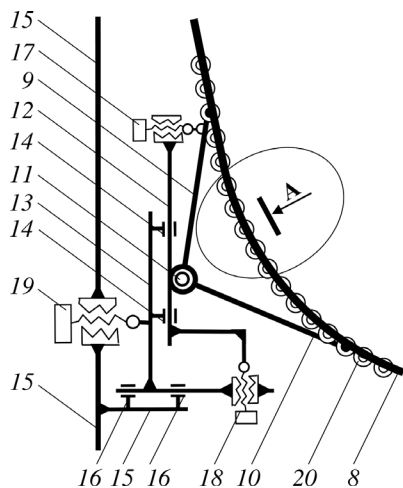

Fig. 4. View of the guiding device of a conveyor: 8 – guide device profile; 9, 10 – levers; 11 – hinge; 12 – tripod; 13 – carriage; 14 – height guiding mechanism; 15 – conveyor frame; 16 – inclination guiding mechanism; 17, 18 – regulating inclination

On the surface of the guiding device, there are rollers protruding from its upper surface to feed the leather (Fig. 5).

As a result, the guiding device of the conveyor, designed to feed the leather into the processing area, will expand the functional and technological capabilities of the roller technological machine by improving the quality of leather processing due to its smooth and uniform feeding into the processing area without wrinkles and folds. Therefore, the productivity and quality of leather processing will be improved, and the reliability of the device and machine will be ensured.

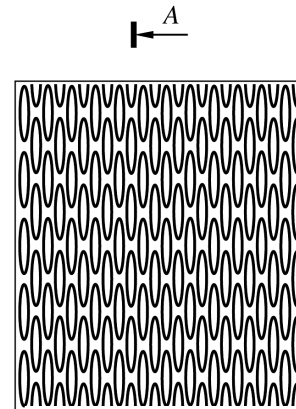

Fig. 5. Scheme of uniform arrangement of rollers of the guiding device (top view)

Fig. 6 shows a 3D view of the proposed device for the mechanical processing of leather.

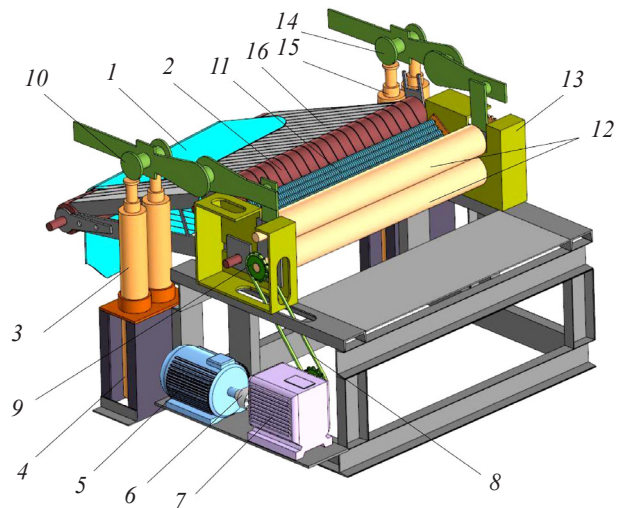

Fig. 6. 3-D view of the proposed roller processing machine for leather machining: 1 – leather; 2 – conveyor rollers; 3, 15 – pressing mechanisms of the working shafts; 4 – rack; 5 – engine; 6 – clutch; 7 – reducer; 8 – chain drive; 9 – sprocket; 10, 14 – bracket; 11 – guiding device; 12 – working rolls; 13 – bed; 16 – strings

Thus, the device and the principle of operation of the developed roller machine with a guiding device are presented, which makes it possible to improve the quality and effective area of the processed leather. The guiding device can also be used in technological machines of similar designs, in particular for processing fur skins.

Planning an experimental study. To conduct the experiment, the second-order  $D$ -optimal planning method was used with the Kano design matrix.

Before conducting the experiment, the required number of measurements (number of repetitions) was chosen by the methods of mathematical statistics, which ensured the required accuracy.

The authors conducted an experiment on a roller stand using the developed guiding device. The working width of the guiding device is 1500 mm, with rollers of a diameter of 30 mm, which straighten the folds of the leather as it is fed into the processing zone between the rotating squeezing rollers.

Based on a priori data, the process of removing moisture was studied taking into account two factors:  $x_1(\alpha)$  – the direction of rotation of the rollers of the guiding device from 0 rad to 0.087 rad, relative to the direction of leather feeding;  $x_2(V)$  – the linear velocity of the strings, m/s – from 0.17 to 0.34 m/s.

The values of the intervals of variation of the input factors of the experiment are given in Table 1.

Table 2 shows the resulting factor of the experiment.

Intervals of experiment factors

Index	Factors	Initial values of factors	
		$x_1$ , rad	$x_2$ , m/s
Upper level	+	0.087	0.340
Mean level	0	0.0435	0.255
Lower level	-	0	0.170
Variation interval		0.0435	0.085

Table 1

Resulting factors of the experiment

Notation	Name	Value
$\Delta S$	Area of leather	m <sup>2</sup>

Table 2

Thus, the planning of the experimental study work was done using known methods.

Mathematical processing of experimental research results. Table 3 shows the initial and final values of the semi-finished

product during the experiment for various values of the straightening angle –  $x_1(\alpha)$  and feed rate –  $x_2(V)$ .

The accuracy and error of the experimental results largely depend on the control of all input and output parameters and their constancy.

Table 3 shows the results of a two-factor experiment and the calculation of their average values.

The homogeneity of the variance was tested using the Cochran test [24, 25] with a confidence level of  $\alpha=0.95$ . Knowing the total number of variables  $N$  and the number of repetitions,  $k=n-1$ , we calculate the values given in Table 2 and obtain  $G_T=0.358$ . Here  $N=9$ ,  $k=n-1=5-1=4$ ,  $n$  – is the number of parallel experiments:

$$S_{er}^2 = \frac{\sum_1^n (y - \bar{y})^2}{n-1} = 3.082, \tag{7}$$

$$\sum_1^N S_i^2 = \frac{\sum_1^N \sum_1^n (y - \bar{y})^2}{N(n-1)} = 0.3476, \tag{8}$$

$$G_{cal} = \frac{S_{max}^2}{\sum_1^N S_i^2} = \frac{0.1225}{0.3476} = 0.3524 < G_T = 0.358. \tag{9}$$

From the calculations, it was determined that the results of the experiment are reproducible.

Table 4 shows the results of determining the regression coefficients of the experiment.

Table 3

Matrix for planning the experiment

No.	$\alpha, x_1$	$V, x_2$	Measurements, %						$\sum_1^n (y - \bar{y})^2$	$S_{er}^2$	$y_{cal}$	$\bar{y} - y_{cal}$	$(\bar{y} - y_{cal})^2$
			$y_1$	$y_2$	$y_3$	$y_4$	$y_5$	$\bar{y}$					
1	0	0	1.8	1.7	1.7	2.3	2.2	1.92	1.32	0.34	2.02	0.64	0.41
2	+	+	0.9	2.3	1.2	0.9	1.2	1.3	1.34	0.33	1.13	0.17	0.0289
3	-	+	1.1	1.3	1.7	1.5	1.0	1.32	1.328	0.33	1.07	0.25	0.0625
4	-	-	2.5	2.3	1.8	1.8	2.5	2.18	1.388	0.347	1.91	0.27	0.0729
5	+	-	2.9	2.6	2.8	2.7	2.8	2.76	1.4	0.35	2.40	0.36	0.1296
6	+	0	2.5	1.9	2.5	2.6	2.4	2.38	1.38	0.345	1.94	0.44	0.1936
7	0	+	1.1	1.0	1.8	1.2	2.4	1.5	1.4	0.35	1.36	0.14	0.0196
8	-	0	2	1.9	0.8	2.1	1.8	1.72	1.36	0.34	1.58	0.14	0.0196
9	0	-	2.7	2.4	2.3	2.5	2.8	2.54	1.4	0.35	2.50	0.04	0.0016

Table 4

Definition of regression coefficients

No.	$\alpha, x_1$	$V, x_2$	Values of coefficients						
			$b_0$	$b_{11}$	$b_{22}$	$b_1$	$b_2$	$b_{12}$	$\bar{y}$
1	0	0	0.5772	-0.3234	-0.3234	0	0	0	1.92
2	+	+	-0.1057	0.1691	0.1691	0.1961	0.1961	0.25	1.3
3	-	+	-0.1057	0.1691	0.1691	-0.1961	0.1961	-0.25	1.32
4	-	-	-0.1057	0.1691	0.1691	-0.1961	-0.1961	0.25	2.18
5	+	-	-0.1057	0.1691	0.1691	0.1961	-0.1961	-0.25	2.76
6	+	0	0.2114	0.1617	-0.3383	0.1078	0	0	2.38
7	0	+	0.2114	-0.3383	0.1617	0	0.1078	0	1.44
8	-	0	0.2114	0.1617	-0.3383	-0.1078	0	0	1.72
9	0	-	0.2114	-0.3383	0.1617	0	-0.1078	0	2.54

Checking the mathematical equation for the adequacy of the results of the experimental study. The results of the adequacy of the obtained equations were checked using the Fisher criterion with a confidence level of  $\alpha=0.95$  [25–28]:

$$F_{cal} = \frac{S_{ad}^2}{S^2\{y\}} < F_T. \tag{10}$$

Here  $S_{ad}^2$  is the residual variance;  $S^2\{y\}$  is the repetition of dispersion:

$$S_{ad}^2 = \frac{\sum_{i=1}^N n(\bar{y} - \bar{y}_i)^2}{N - \frac{(k+2)(k+1)}{2}} = 0.897. \tag{11}$$

Here  $N$  is the total number of experiments;  $k$  is the number of variables;  $n$  is the number of repetitions of the experiment;  $y_i$  is the number of individual observations;  $\bar{y}$  is the arithmetic mean of the results of the experiment;  $y_{cal}$  is the calculated value of the criteria according to the regression equation:

$$S_{(y)}^2 = \frac{\sum_{i=1}^N \sum_{j=1}^n (y - \bar{y})^2}{N(n-1)} = 0.3476. \tag{12}$$

The adequacy of the obtained model was checked by the Fisher criterion:

$$F_{cal} = \frac{S_{ad}^2}{S^2\{y\}} = \frac{0.897}{0.3476} = 2.580 < F_T = 2.880. \tag{13}$$

Thus, the adequacy of the mathematical equation was verified based on the results of the experimental study. The results correspond to the normal distribution curve and the reproducibility conditions of the experimental study.

**5. Results of theoretical and experimental studies of rational design, geometric, and technological parameters of the guiding device**

**5.1. The results of a theoretical study to determine the surface profile of the guide device**

On the basis of theoretical study, a differential equation was derived, which makes it possible to determine the curvature of the guide surface of the transporting device. From engineering considerations, we set the values and substituted them into the differential equation, which describes the profile of the guide surface.

From expressions (2)–(4) we obtain the following differential equation:

$$y'' = \frac{Q}{m} \cdot \frac{g(f - y')(1 + y'^2)}{-\frac{\delta}{r}v^2 + \frac{E}{\rho}(1 + y'^2)^{\frac{3}{2}}}. \tag{14}$$

Knowing the geometric parameters of the roller stand and using the numerical Runge-Kutta method, a graphical solution was obtained showing the curvature of the concavity of the guide surface.

From the calculation-graphical program, we choose a graphical solution to the differential (14) that satisfies initial conditions  $y(0)=h$  and  $y(l)=0$ .

Condition  $y' < 0$  shows that the curved line is decreasing. Condition  $y'' \geq 0$  shows that the curved line is concave. Solutions must meet these conditions. We obtain a graphical solution that satisfies these conditions of differential (14) for the following given rational values  $h=0.3$  m,  $l=0.3$  m,  $V=0.2$  m/s,  $\Delta=0.001$  m,  $r=0.03$  m,  $E=105$  Pa,  $\rho=103$  kg/m<sup>3</sup> [2].

The graphical solution of differential (14) (Fig. 7) was obtained using the Maple calculation and graphic program [29], and the Runge-Kutta numerical method [30].

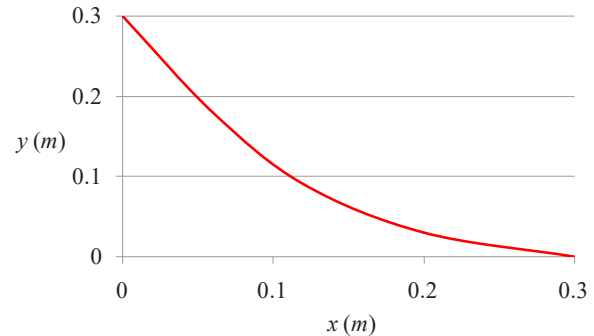

Fig. 7. Graphic solution of the guiding surface profile

The graphic solution in Fig. 7 allows to choose the profile of the guiding surface of the device, which ensures a smooth supply of leather from the conveyor to the area between the working rollers. As a result, this leads to the elimination of defects and losses of finished products. Consequently, the implementation of such measures in the leather industry ultimately leads to significant savings in raw materials.

It is determined that the guide surface has the shape of a part of a parabola (Fig. 7).

**5.2. The results of determining the parameters of the guide device of the feed-through roller squeezing machine**

It was determined that considering the efficiency of straightening the folds of the supplied skin, the rollers mounted on cylindrical rods in several rows (in this case, 6 rows with 50 rollers in each row) must rotate freely around their axis. The rollers of each row are installed in a checkerboard pattern so that the location of the rollers of each row does not coincide with the rollers of the next row. The rollers, on cylindrical rods, are installed at a certain angle (0.087 rad), symmetrically to the right and left end sides from the center (Fig. 8).

The rollers can be installed in a checkerboard pattern, and at a certain angle relative to each other (Fig. 8).

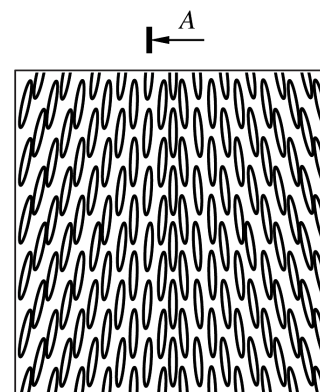

Fig. 8. Scheme of arrangement of the straightening rollers of the guiding device (top view)

A 3-D view of the guiding device is shown in Fig. 9.

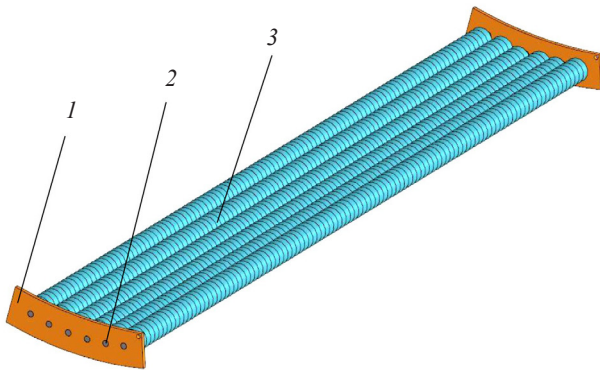

Fig. 9. 3D view of the design of the guiding device:  
1 – metal sidewalls; 2 – metal axes; 3 – rollers

At that, the best straightening of skin folds is achieved. Taking into account the fact that the working width of the pass of the roller stand is 1500 mm, the width of the guide device was also 1500 mm, the diameters of the rollers were 40 mm, the thickness was 20 mm, and the diameters of the cylindrical rods were 15 mm. It should be noted that the angle of the rollers might vary depending on the type and thickness of the hides being treated.

**5. 3. The results of an experimental study to determine the technological parameters of the roller squeezing machine and guide device**

Based on these data, below we present the results of an experiment performed on a roller stand. The test was performed to determine the feed rate, and the pressure of the working rolls, allowing to ensure the straightening of the folds and the increase in the usable area of the wet skin. Mathematical calculations of the straightening of the effective area (in percent) during feeding leather to the processing area are presented in Table 5.

Based on the results of the experiment, the regression equation (12) was obtained in a named form. The regression equation (12) makes it possible to determine the dependence of the increase in the usable area of the wrung wet hide on the change in the angle of the rollers and the rate of the hide supply between the working rolls. A work plan was drawn up for the implementation of the experiment.

Regression coefficients  $b_0, b_i, b_{ij}, b_{ii}$  are defined from Table 5.

Regression coefficients for leather are  $b_0=2.017244$ ;  $b_{11}=-0.26$ ;  $b_{22}=-0.086$ ;  $b_1=0.18$ ;  $b_2=-0.57353$ ;  $b_{12}=-0.15$ .

We obtain the regression equation for leather:

$$y = 2.017244 - 0.26x_1^2 - 0.086x_2^2 + 0.18x_1 - 0.57353x_2 - 0.15x_1x_2. \tag{14}$$

Equalities  $x_1 = (\alpha - 0.0435)/0.0435$ ,  $x_2 = (V - 0.255)/0.085$  are substituted into (11). Here  $\alpha$  is the direction of rotation of the guiding rollers and the angle of straightening to the right and left sides relative to the direction of leather movement, and  $V$  is the constant linear velocity of leather movement:

$$\Delta S = 0.7178 - 2.122449\alpha^2 - 11.07266V^2 + 4.7714\alpha + 2.429V - 5.042\alpha V. \tag{15}$$

Graphical solutions of regression equation (12) are obtained for the selected velocities and angles using the Microsoft Excel graphic program (Fig. 10, 11).

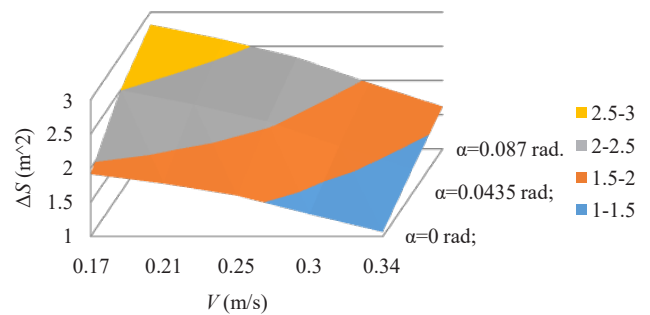

Fig. 10. Graph of dependence of the change in the useful area of leather on the rate of its feeding

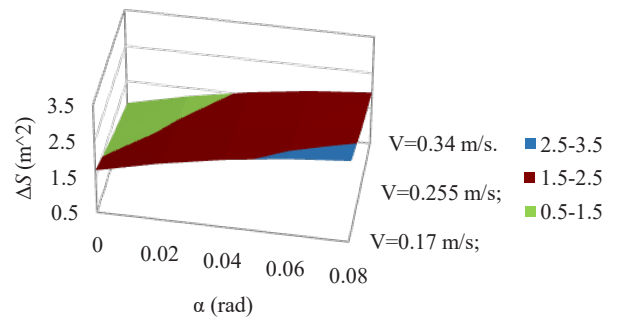

Fig. 11. Graph of dependence of the change in the useful area of leather on the feed angle of straightening

Initial and final areas of leather

Table 5

No.	$\alpha, x_1$	$V, x_2$	$y_1, m^2$		$y_2, m^2$		$y_3, m^2$		$y_4, m^2$		$y_5, m^2$	
			$y_{in1}$	$y_{fm1}$	$y_{in2}$	$y_{fm2}$	$y_{in3}$	$y_{fm3}$	$y_{in4}$	$y_{fm4}$	$y_{in5}$	$y_{fm5}$
1	0	0	0.48	0.489	0.5	0.509	1.12	1.14	0.98	1.003	0.25	0.255
2	+	+	0.64	0.646	0.86	0.88	0.42	0.425	0.78	0.787	0.40	0.405
3	-	+	1.2	1.213	1.1	1.115	0.56	0.57	0.66	0.67	0.84	0.849
4	-	-	0.90	0.923	1.2	1.228	0.54	0.55	0.48	0.489	0.58	0.595
5	+	-	0.80	0.824	1	1.027	0.84	0.864	0.72	0.74	1.18	1.215
6	+	0	0.55	0.564	0.96	0.979	0.98	1.005	0.68	0.698	0.8	0.82
7	0	+	0.7	0.708	0.88	0.889	1.0	1.019	0.44	0.4456	0.6	0.615
8	-	0	0.75	0.765	0.60	0.612	1.16	1.169	0.36	0.368	0.94	0.957
9	0	-	1.0	1.028	0.74	0.758	0.82	0.839	1.08	1.108	0.62	0.638



A graph of dependence of the increase in usable area –  $\Delta S$  on the feed rate –  $V$  when the skin is fed into the treatment zone between the rotating squeezing rollers (Fig. 10) is plotted. A graph of dependence of the increase in usable area –  $\Delta S$  on the angle of the guiding rollers –  $\alpha$  (Fig. 11) was built.

## 6. Discussion of the results the determination of rational design, geometric, and technological parameters of the guiding device

Based on a new technical solution, the authors have improved the design of a roller machine for squeezing excess moisture from wet leather after its liquid treatment (Fig. 3). The parameters of the skin guiding device were studied. The operating modes of the roller squeezing machine were determined.

The results of the theoretical study made it possible to draw the following conclusions. Differential equation (14) was derived, which made it possible to determine the profile of the rational curvature of the surface of the guiding device for the ideal skin sliding under the influence of its own weight.

The graphical method shows the ideal curvature of the surface of the guiding device, obtained by means of a graphical solution (Fig. 7). In addition, on the basis of these results, we designed a guiding device shown in Fig. 4. This device is applied in the design of the roller squeezing machine (Fig. 6).

In the well-known works, for example [4], the influence of the motion of a homogeneous body along a curved surface with free sliding was considered. In [5], the influence of the curvature of a curved surface on the sliding of solids with high friction was studied.

It is known that leather is an elastic-plastic, natural material that has a non-homogeneous structure throughout its topography. For example, on the shoulder section, the skin has a denser structure and greater thickness, and on the belly section, it is loose and of less thickness. Consequently, different topographic sections of the skin, due to their characteristics have different abilities to straighten transverse and longitudinal folds.

In order to determine the ability to straighten, as well as the increase in the useful area of the skin during its transportation, we conducted a test on a roller machine in experimental setting. The results in Table 3 show that the average gain in usable skin area was 1–1.5 percent.

That is, we have achieved the following: due to the use of the proposed guiding device, the transverse and longitudinal folds are straightened, and the useful area of the skin is increased.

From the point of view of socio-economic efficiency, this provides additional opportunities in obtaining value-added finished leathers due to the elimination of constant manual straightening of folds on the skin by the attendants.

Thus, the influence of the parameters of the device developed by us on the qualitative (straightening) and quantitative (area gain) properties of the treated wet skins was studied.

A critical analysis of the results obtained in experimental and theoretical studies clearly shows that the task set before us has been fulfilled in general.

The results of the experiment allow drawing the following general conclusions. The proposed guiding device made it possible to feed the skin without transverse and longitudinal folds. In addition, the possibility of increasing the area of the skin during its feeding was obtained.

An analysis of the results of well-known experimental studies showed that when pressing wet leather between the squeezing rollers, the increase in usable area was insignificant.

However, on the existing squeezing machines, the requirements for the squeezing technology were met; namely, the residual moisture of leather was 55–60 %, of the total moisture of 78 %.

In our case, in addition to providing the required amount of moisture content in leather, due to the use of a roller guiding device, the useful area of the skin also increased.

It should be noted that the guiding device could only be used in the designs of roller machines of the through type. The use of a guiding device on roller machines of a non-through type is ineffective.

The designed guiding device is suitable for roller processing machines with a working width of passage up to 2200 mm. At a larger width, there is a possibility of deflection of the guiding device along its length. This requires an additional study on the deflection of the guiding device.

Thus, the regression equation can be calculated with a confidence level of 95 %. After decoding, it has the following form in the named form for the guiding device to feed the leather to the processing area.

Analysis of the graph in Fig. 10 showed that at small values of the feed angle of straightening of the guiding rollers that feed the leather into the processing area, an increase in the linear feed rate of the actuating elements leads to a reduction in the usable area of leather.

Analysis of the graph in Fig. 11 showed that at small values of the linear feed rate of the actuating elements of the device, the useful area of the leather increases at a large feed angle of straightening of the rollers of the guiding device.

The results obtained make it possible to select rational kinematic and geometric parameters of the device for feeding a semi-finished leather product to the machining zone without longitudinal and transverse folds of leather.

The results obtained in an experimental study on the substantiation of the initial parameters of the guiding device developed by the authors made it possible to select the rational parameters of this device.

The guiding device is distinguished by its simple structure and ease of installation and dismantling, and maintenance. The novelty of the guiding device is confirmed by a patent (UZ) [19].

The results obtained in the experiment make it possible to simulate the process of feeding and squeezing wet leathers using the derived regression equations in coded and named forms. From an engineering point of view, it is possible to choose the main parameters of the working bodies of the roller squeezing machine and its guiding device.

The results allow the engineers to calculate and select the rational parameters of the guiding device, taking into account the technological modes specified by the customers.

Further, all the criteria taken into account by the authors that affected the increase in the productivity of the technological process and the squeezing machine were given in detail.

When the guiding rollers rotate perpendicular to the processed section of leather, that is, at an angle of  $\alpha=0$  rad, the maximum linear velocity of the conveyor strings is  $V=0.34$  m/s, and the useful area of the leather is small (Fig. 5).

At that, a uniform feed of skin to the treatment area was observed. However, after measuring the area of the skin, it was found that in this case, the increase in the effective area of the skin was insignificant.

At the feed angle of straightening of the guide rollers  $\alpha=0.0435$  rad and the average linear velocity of the conveyor strings  $V=0.255$  m/s, the useful area of the leather increases by an average of 2.01 %.

In this case, a uniform feed of the skin to the treatment area was also observed. Here, the feed rate was lower than in the previous case and the angle of the roller position relative to the direction of the skin was greater. In this case, an increase in the effective area of the skin was reached by changing the angle of the rollers.

At the feed angle of straightening of the guide rollers  $\alpha=0.087$  rad and the minimum linear velocity of the conveyor strings  $V=0.17$  m/s, the useful area of the processed leather increases by an average of 2.5 %.

In this case, a uniform feed of the skin to the treatment area was also observed. At that, the feed rate was lower than in previous cases of processing. But, the angle of the roller position relative to the direction of the skin was changed to a large inclination. In this case, the change in the angle of the rollers gave the greatest increase in the effective area of leather (Fig. 8).

Taking into account the technological requirements for pressing wet leathers, it is recommended to perform the processing on a roller machine using a guiding device at a feed rate of  $V=0.255$  m/s and at an angle of the rollers relative to the skin direction  $\alpha=0.087$  rad.

The total increase in the useful area for the output of a batch of finished leather, taking into account their shrinkage and aging on pallets, can amount to approximately 50 %.

As a result of the experimental study conducted on a roller stand using a new guiding device in the design of the conveyor, it is possible to increase the gain of the useful area of the processed leather by an average of 1.52 % (Table 5).

In contrast to the existing roller technological machines, which use simple conveyors, the design of the roller squeezing machine proposed by the authors uses a new guiding device that allows for the straightening of folds on the fed leather before squeezing out its excess moisture. Due to the use of rollers installed at a certain angle relative to each other, it allows an additional increase in the useful area of the leather output. From an economic point of view, this provides significant material savings.

Thus, the results of theoretical and experimental studies obtained, show that the use of the device developed by the authors with an improved guiding element that moves leather semi-finished products to the machining zone will increase the usable area of finished leathers while maintaining the quality of the processed leather materials.

In this study, we did not consider the influence of the friction force between the skin and the rollers of the guiding device. The influence of the types of processed leather on the rollers of the device was not taken into account. Besides, the influence of the material of the rollers on their durability, moisture resistance, and reliability was not studied. This research will be conducted by the authors in the future.

---

## 7. Conclusions

---

1. Analytical expressions were obtained for calculating the geometric and design parameters of the profile of the guiding device of a roller technological machine. These expressions are

differential equations that allow determining the profile (curvature) of the guide surface of the straightening device. This profile changes depending on the change in skin type. It should be noted that depending on the change in the type of processed leather, the values of the mass, density, and, accordingly, the friction coefficient of the skin change. Therefore, the feeding rate of the skin between the working rolls can also vary. In addition, the change in the radii of the working rolls affects the conditions for feeding and capturing the skin into the treatment area between the rotating working rolls. All these parameters of the straightening device of the squeezing machine may vary depending on the specific requirements of the technological process of wet leather treatment.

2. Based on the analytical expressions obtained, the geometric parameters of the guiding device were selected. The diameters of the guide rollers were determined. The diameters and lengths of the rods carrying these rollers are determined; they can vary depending on the types of skins and the working width of the passage of the technological machine. The results of the calculations served for the manufacture of an experimental guiding device for a roller squeezing machine with a working passage width of 1500 mm.

3. On the basis of the experiment, the optimal operating modes of the feed rate and the pressing force of the rolls of the squeezing machine were determined. The values of the angle of position of the rollers of the guiding device were estimated. It was established that with an increase in the angle of the rollers relative to the vertical line, the straightening of the folds on the skin increases. This increases the useful area of the treated skin. For example, compared to known technological machines, for example, the Svit roller squeezing machine or the GJST4 320 feed-through roller machine, in the method proposed by the authors, the treated hide is flattened before being pressed. Due to further processing under the pressure of the working rolls, the yield of the useful area of the straightened skin increases. Thus, the use of a simplified guiding device simplifies the design of a roller technological machine for pressing wet raw hides after chrome tanning, ensuring effective straightening of the folds on the skin.

---

## Conflicts of Interest

---

The authors declare that they have no conflict of interest in relation to this research, whether financial, personal, authorship or otherwise, that could affect the research and its results presented in this paper.

---

## Financing

---

The study was performed without financial support.

---

## Data availability

---

Manuscript has no associated data.

---

## References

1. Leather production in the world. Available at: <http://www.splaix.ru/k5.html>
2. Burmistrov, A. G. (2006). Machines and apparatus for the production of leather and fur. Moscow: KolosS, 384. Available at: [https://rusneb.ru/catalog/000199\\_000009\\_002909428/](https://rusneb.ru/catalog/000199_000009_002909428/)

3. Leather Processing & Tanning Technology Handbook (2011). NIIR Board of Consultants & Engineers, 592. Available at: <https://books.google.com.hk/books?id=hbKkCwAAQBAJ>
4. Gallardo, J. P., Pettersen, B., Andersson, H. I. (2013). Effects of free-slip boundary conditions on the flow around a curved circular cylinder. *Computers & Fluids*, 86, 389–394. <https://doi.org/10.1016/j.compfluid.2013.07.023>
5. Schultz, R. A. (1992). Mechanics of curved slip surfaces in rock. *Engineering Analysis with Boundary Elements*, 10 (2), 147–154. doi: [https://doi.org/10.1016/0955-7997\(92\)90045-9](https://doi.org/10.1016/0955-7997(92)90045-9)
6. Nabiev, A., Tsoy, G., Bahadirov, G. (2023). Conditions for vertical pulling of semi-finished leather products under driving rollers. *E3S Web of Conferences*, 376, 01073. doi: <https://doi.org/10.1051/e3sconf/202337601073>
7. Muhammad, R., Khan, M. I., Khan, N. B., Jameel, M. (2020). Magneto hydrodynamics (MHD) radiated nanomaterial viscous material flow by a curved surface with second order slip and entropy generation. *Computer Methods and Programs in Biomedicine*, 189, 105294. doi: <https://doi.org/10.1016/j.cmpb.2019.105294>
8. Hayat, T., Qayyum, S., Alsaedi, A., Ahmad, B. (2020). Entropy generation minimization: Darcy-Forchheimer nanofluid flow due to curved stretching sheet with partial slip. *International Communications in Heat and Mass Transfer*, 111, 104445. doi: <https://doi.org/10.1016/j.icheatmasstransfer.2019.104445>
9. Avramenko, A. A., Kuznetsov, A. V. (2009). Instability of a slip flow in a curved channel formed by two concentric cylindrical surfaces. *European Journal of Mechanics – B/Fluids*, 28 (6), 722–727. doi: <https://doi.org/10.1016/j.euromechflu.2009.06.003>
10. Failli, F., Dini, G. (2004). An Innovative Approach to the Automated Stacking and Grasping of Leather Plies. *CIRP Annals*, 53 (1), 31–34. doi: [https://doi.org/10.1016/s0007-8506\(07\)60638-6](https://doi.org/10.1016/s0007-8506(07)60638-6)
11. Bacardit, A., Baquero, G., Sorolla, S., Ollé, L. (2015). Evaluation of a new sustainable continuous system for processing bovine leather. *Journal of Cleaner Production*, 101, 197–204. doi: <https://doi.org/10.1016/j.jclepro.2015.04.012>
12. Adzet, J. M. A. (2010). Pat No. WO2010070571A3. Procedure for the tanning of skins, material obtained during said procedure and device. Available at: <https://patents.google.com/patent/WO2010070571A3/en>
13. Purnomo, E. (2015). Teknik Penyamakan Aldehida dan Sintetis. Yogyakarta.
14. Morera, J. M., Bacardit, A., Olle, L., Costa, J., Germann, H. P. (2006). Study of a Chrome Tanning Process without Float and with Low-Salt Content as Compared to A Traditional Process Part II. *Journal of the American Leather Chemists Association*, 101 (12), 454–460. Available at: <https://agris.fao.org/agris-search/search.do?recordID=US201300783975>
15. Loan, S., Liu, Y., Fan, H., Shi, B., Duan, Z. (2007). A novel pre-tanning agent for high exhaustion chromium tannage. *Journal of the Society of Leather Technologists and Chemists*, 91 (4), 149–153. Available at: <https://www.scholarmate.com/A/MZFzIr>
16. Luo, Z., Zhang, X., Fan, H. et al. (2009). Modification of collagen for high Cr(III) absorption. *Journal of the American Leather Chemists Association*, 104, 149–155. Available at: <https://journals.uc.edu/index.php/JALCA/article/view/2477/1838>
17. Sundar, V. J., Rangasamy, T., Sivakumar, V., Muralidharan, C. (2007). A Novel Pickle-Free High Exhaust Chrome Tanning Method – An Approach for Total Dissolved Solids Management. *Journal of the Society of Leather Technologists and Chemists*, 88 (5), 252–255.
18. Thanikaivelan, P., Kanthimathi, M., Rao, J. R., Nair, B. U. (2002). A Novel Formaldehyde-Free Synthetic Chrome Tanning Agent for Pickle-Less Chrome Tanning: Comparative Study on Syntan versus Modified Basic Chromium Sulfate. *Journal of the American Leather Chemists Association*, 97 (4), 127–136. Available at: <http://www.csircentral.net/index.php/record/view/50302>
19. Bahadirov, G. A., Abdugarimov, A., Bahadirov, K. G., Musirov, M. U., Saidakhmetova, N. B. (2021). Pat. No. 01658 UZ. Device for processing sheet material.
20. Bahadirov, G., Sultanov, T., Tsoy, G., Nabiev, A. (2021). Experimental dehydration of wet fibrous materials. *E3S Web of Conferences*, 264, 04060. doi: <https://doi.org/10.1051/e3sconf/202126404060>
21. Bahadirov, G. A., Nosirov, M. I. (2022). Research and Analysis of Rational Parameters for a Conveying Mechanism of a Multi-operation Roller Machine. *Proceedings of the 7<sup>th</sup> International Conference on Industrial Engineering (ICIE 2021)*, 154–165. doi: [https://doi.org/10.1007/978-3-030-85233-7\\_18](https://doi.org/10.1007/978-3-030-85233-7_18)
22. Amanov, A. T., Bahadirov, G. A., Nabiev, A. M. (2023). A Study on the Pressure Mechanism Improvement of a Roller-Type Machine Working Bodies. *Materials*, 16 (5), 1956. doi: <https://doi.org/10.3390/ma16051956>
23. Amanov, A. T., Bahadirov, G. A., Tsoy, G. N., Nabiev, A. M. (2023). The Improvement of the Rheological Model of Leather. *International Journal on Advanced Science, Engineering and Information Technology*, 13 (1), 321. doi: <https://doi.org/10.18517/ijaseit.13.1.17360>
24. Jeff Wu, C. F., Hamada, M. S. (2009). Experiments: planning, analysis, and optimization. John Wiley & Sons, Inc., 760.
25. Tikhomirov, V. A. (1974). Planning and analysis of the experiment. Moscow: Light industry, 283.
26. Constales, D., Yablonsky, G. S., D'hooge, D. R., Thybaut, J. W., Marin, G. B. (2017). Experimental Data Analysis. *Advanced Data Analysis & Modelling in Chemical Engineering*, 285–306. doi: <https://doi.org/10.1016/b978-0-444-59485-3.00009-6>
27. Fávero, L. P., Belfiore, P. (2019). Design and Analysis of Experiments. *Data Science for Business and Decision Making*, 935–939. doi: <https://doi.org/10.1016/b978-0-12-811216-8.00021-5>
28. Farooq, M. A., Nóvoa, H., Araújo, A., Tavares, S. M. O. (2016). An innovative approach for planning and execution of pre-experimental runs for Design of Experiments. *European Research on Management and Business Economics*, 22 (3), 155–161. doi: <https://doi.org/10.1016/j.iedee.2014.12.003>
29. Sharma, A. K. (2005). Text Book of Circles and Parabola. Discovery Publishing House, 308.
30. Butcher, J. C. (1987). The Numerical Analysis of Ordinary Differential Equations: Runge-Kutta and General Linear Methods. Wiley, 528.