

The object of this study is the process of detecting and determining the coordinates of stealth unmanned aerial vehicles by a network of two small-sized radars. The main hypothesis of the study assumes that the use of two small-sized radars, which are connected in a network, could improve the quality of detection and determination of the coordinates of stealth unmanned aerial vehicles.

The improved method for detecting and determining the coordinates of a stealth unmanned aerial vehicle, unlike the known ones, enables the following:

- synchronous inspection of the airspace;
- reception of the signal reflected from a stealth unmanned aerial vehicle by two small-sized radars;
- carrying out coordinated filtering of incoming signals;
- compensation of phase shifts and coherent addition of output signals from matched filters;
- formation of Doppler channels in each small-sized radar and formation of a complex envelope from the output of the corresponding Doppler channel;
- coherent processing (addition) of signals;
- compensation of the random initial phase of signals reflected from a stealth unmanned aerial vehicle by detecting the output signal from the coherent adder;
- measuring the range to a stealth unmanned aerial vehicle by each small-sized radar;
- calculation of the coordinates of a stealth unmanned aerial vehicle.

It was established that at low signal/noise values, the gain in terms of the conditional probability of correct detection is from 25 % to 32 %. It was determined that the use of a network of two small-sized radars makes it possible to reduce the mean square error in determining the coordinates of a stealth unmanned aerial vehicle from 28 % to 37 % on average

**Keywords:** small-sized radar, determination of coordinates, two-position network, conditional probability of correct detection

# IMPROVING A METHOD FOR DETECTING AND MEASURING COORDINATES OF A STEALTH AERIAL VEHICLE BY A NETWORK OF TWO SMALL-SIZED RADARS

**Hennadii Khudov**

*Corresponding author*

Doctor of Technical Sciences, Professor, Head of Department  
Department of Radar Troops Tactic\*  
E-mail: 2345kh\_hg@ukr.net

**Andrii Berezhnyi**

PhD

Chief of the University\*

**Serhii Yarosh**

Doctor of Military Sciences, Professor  
Department of Anti-Aircraft Missile Forces Tactic\*

**Oleksandr Oleksenko**

PhD, Head of Department

Department of Scientific Research  
Air Force Command of UA Armed Forces  
Striletska str., 105, Vinnytsia, Ukraine, 21007

**Mykola Khomik**

Doctor of Technical Sciences, Senior Researcher, Leading Researcher  
Military and Strategic Research Centre  
The National Defence University of Ukraine  
Povitroflotskyi ave., 28, Kyiv, Ukraine, 03049

**Iryna Yuzova**

PhD, Lecturer

Department of Information Technologies  
Civil Aviation Institute  
Klochivska str., 228, Kharkiv, Ukraine, 61023

**Andrii Zvonko**

PhD, Senior Lecturer

Department of Rocket Artillery Armament  
Hetman Petro Sahaidachnyi National Army Academy  
Heroiv Maidanu str., 32, Lviv, Ukraine, 79012

**Serhii Yarovyi**

PhD, Senior Lecturer

Department of Combat Use of Radar Armament\*

**Sergey Glukhov**

Doctor of Technical Sciences, Professor, Head of Department  
Department of Military and Technical Training  
Military Institute of Taras Shevchenko National University of Kyiv  
Yuliyi Zdanovskoi str., 81 Kyiv, Ukraine, 03189

**Anatolii Sobora**

PhD, Leading Researcher

Department of Testing Armaments and Military (Special) Equipment  
State Scientific Research Institute of Armament and Military Equipment Testing and Certification  
Strilets'ka str., 1, Chernihiv, Ukraine, 14033  
\*Ivan Kozhedub Kharkiv National Air Force University  
Sumska str., 77/79, Kharkiv, Ukraine, 61023

Received date 05.10.2023 **How to Cite:** Khudov, H., Berezhnyi, A., Yarosh, S., Oleksenko, O., Khomik, M., Yuzova, I., Zvonko, A., Yarovyi, S., Glukhov, S., Sobora, A.

Accepted date 12.12.2023 (2023). Improving a method for detecting and measuring coordinates of a stealth aerial vehicle by a network of two small-sized radars.

Published date 21.12.2023 Eastern-European Journal of Enterprise Technologies, 6 (9 (126)), 6–13. doi: <https://doi.org/10.15587/1729-4061.2023.293276>

## 1. Introduction

One of the main trends in modern armed conflicts (for example, the Israeli-Palestinian, Russian-Ukrainian

war, etc.) is the widespread use of stealth unmanned aerial vehicles [1, 2]. Typical stealth unmanned aerial vehicles are cruise missiles, unmanned aerial vehicles, anti-radar missiles, etc. [3–5].

Among current methods for detecting stealth unmanned aerial vehicles (for example, acoustic, visual, thermal, radio frequency, etc.), the most effective are the those involving modern *radars*. Moreover, many air defense systems use small-sized radars (for example, [6, 7]). Small-sized radars have certain disadvantages, which are primarily related to their small dimensions and, accordingly, a wide directional pattern. This leads to a deterioration in the accuracy of determining the coordinates of stealth unmanned aerial vehicles.

To increase the accuracy of determining the coordinates of stealth unmanned aerial vehicles, several small-sized radars of the same type are used, which are combined into a network (for example, [8, 9]). In such networks, by using system effects, it is possible to improve the accuracy of determining the coordinates of stealth unmanned aerial vehicles. Known works on combining two small-sized radars into a two-position network only consider increasing the accuracy of determining the coordinates of aerial objects. At the same time, a method for detecting a signal reflected from a stealth unmanned aerial vehicle remains outside the scope of consideration. The detection of a signal from a stealth unmanned aerial vehicle in a two-position network of small-sized radars is directly related to an increase in the accuracy of determining the coordinates of aerial objects.

Therefore, improving the method for detecting and measuring the coordinates of a stealth unmanned aerial vehicle by a network of two small-sized radars is an urgent task.

---

## 2. Literature review and problem statement

---

In [10], to improve the quality of object detection, radar emission of complex probing signals is proposed. The use of methods [10] leads to the complication of complex signal detection algorithms and cannot be used in small-sized radars.

In [11], the process of detecting and determining the coordinates of objects is carried out by the range-finding method and its variants (difference-range-range, total-difference-range-range). It is noted that the methods [11] are effective with a narrow radar directional pattern, which makes it impossible to use them in small-sized radars.

In [12], increasing the quality indicators of cruise missile detection is ensured by combining surveillance radars into the network. The disadvantage of [12] is the impossibility of providing a synchronous survey of the air space, which negates the advantages of the method [12].

In [13], methods for increasing quality indicators due to the creation of a network of two radars with mechanical rotation are considered. The disadvantage of [13] is the lack of ensuring coherence of signals and their coherent processing, which makes compatible processing of signals reflected from an aerial object impossible.

In [14], the increase in quality indicators is ensured by adding the energy of cellular communication signals. The disadvantage of [14] is the impossibility of practical implementation of the synchronization of cellular communication stations and radar.

In [15], an improvement of the method from [14] was proposed but with the use of two radars. Adding another radar only exacerbates the problem of synchronizing the operation of cellular communication stations and two radars.

In [15], the increase in quality indicators is ensured by adding the energy of navigation signals. The disadvantage of [15] is the impossibility of practical implementation of synchronization of navigation signal sources and radar.

In [16], the increase in quality indicators is ensured by adding the energy of the television signal and creating an additional receiving channel of the television signal. The disadvantage of [16] is the need to equip the radar with additional equipment, which is impossible in small-sized radars.

In [17], the development of [16] was proposed and the radar detection zone was calculated with the addition of television signal energy. It was established that the main drawback of [18] is the appearance of a powerful penetrating signal through an additional reception channel.

In [18], navigation methods for increasing the accuracy of determining the coordinates of aerial objects (methods of the Loran-C navigation system (USA)) are proposed. The disadvantage of [18] is the use of navigation methods only for solving navigation tasks.

In [19], an increase in accuracy is achieved by using multilateration systems. The disadvantage of [19] is the effective operation of such multilateration systems at a limited distance, which makes it impossible to use such systems in small-sized radars.

In [20], increasing the distance and increasing the accuracy are achieved using the Wide Area Multilateration (WAM) system. The disadvantage of [20] is the low power of the reflected signals under the conditions of increased distance of the multilateration system.

In [21], theoretical calculations were performed and an improved method for maximum likelihood was proposed. The disadvantage of [21] is the use of multidimensional complex objective functions. This predetermines a more theoretical than practical orientation [21].

Improvements to [22] and the use of linear and quadratic functions of the maximum likelihood method are given in [21]. In [21], it was possible to reduce the dimensions of the search space for complex objective functions. The disadvantage of [22] is the bias and suboptimality of the obtained estimates of the coordinates of the aerial object.

In [23], quality indicators are increased by adding energy to the sound source of information. The disadvantage of [23] is the impossibility of practical implementation of the synchronization of the sound information source and the radar.

In [24], the improvement of quality indicators is provided by the use of only a sound signal when detecting an unmanned aerial vehicle. The disadvantage of [24] is the limited detection range of an aerial object.

In [25], a method for detecting an unmanned aerial vehicle of the multi-rotor drone type is considered. Detection is provided by a small-sized radar. The disadvantage of [25] is the impossibility of combining such small-sized radars into a network.

In [26], a method for making structural changes to the radar antenna and reducing the size of its directional pattern is considered. The disadvantage of [26] is the introduction of changes in the design of the radar antenna system.

An analysis of the Multiple-Input and Multiple-Output (MIMO) radar directional pattern is given in [27]. It has been established that the use of MIMO radar improves the quality of solving various tasks using radio engineering systems. At the same time, [27] has a more theoretical value, considering the solution of communication issues, evaluation of parameters of received signals, etc. The results of [27] cannot be directly applied to the detection and determination of coordinates by small-sized radars.

Study [28] provides a brief overview of the basic methods for designing MIMO radar signals. Methods for signal formation are taken into account, taking into account the minimi-

zation of the influence of interference, the level of correlation, etc. At the same time, the criterion of minimizing the signal/noise ratio is used. The disadvantage of [28] is the impossibility of practical implementation in a two-position network of small-sized radars.

In [29], a genetic method is used to combine several radars into a network. The drawback of [29] is the dependence of the method on the flight path of aerial objects. This makes it difficult to use [29] to detect aerial objects by a network of two small-sized radars.

Thus, known methods for detecting and determining the coordinates of stealth unmanned aerial vehicles involve either a structural change in the radar or an increase in the complexity of information processing. Combining radar into a network improves the quality of information processing but known methods are mainly aimed at building MIMO systems to solve communication tasks.

Therefore, it is necessary to conduct further research on improving a method for detecting and measuring the coordinates of a stealth unmanned aerial vehicle using a network of two small-sized radars.

### 3. The aim and objectives of the study

The purpose of this study is to improve the quality of detection and measurement of the coordinates of a stealth unmanned aerial vehicle by a network of two small-sized radars. This will make it possible to meet the requirements for the quality of detection and the accuracy of determining the coordinates of stealth unmanned aerial vehicles.

To achieve the goal, it is necessary to solve the following tasks:

- to state the main stages of the method for detecting and measuring the coordinates of a stealth unmanned aerial vehicle using a network of two small-sized radars;
- to evaluate the quality of detection and measurement of the coordinates of a stealth unmanned aerial vehicle by a network of two small-sized radars.

### 4. The study materials and methods

The object of our research is the process of detecting and measuring the coordinates of stealth unmanned aerial vehicles by a network of two small-sized radars.

The main hypothesis of the study assumes that combining two small-sized radars into a network could improve the quality of detection and measurement of the coordinates of stealth unmanned aerial vehicles.

The following research methods were used during the research:

- methods for digital signal processing;
- differential calculus methods;
- methods for probability theory and mathematical statistics;
- radar location methods;
- methods for statistical theory of detection and measurement of parameters of radar signals;
- methods for multi-position radar;
- mathematical apparatus of matrix theory;
- iterative methods;
- methods for system analysis;
- methods for mathematical modeling.

The following limitations and assumptions were adopted during the research:

- small-sized radars with digital signal processing are considered;
- a stealth unmanned aerial vehicle is an air object from which the reflected radar signal in the direction of the radar has a low value of the signal-to-noise ratio;
- conditions for receiving a reflected signal from a stealth unmanned aerial vehicle are provided by each small-sized radar;
- the survey of the airspace by small-sized radars is synchronous;
- conditions for coherent processing of the reflected signal from a stealth unmanned aerial vehicle are provided;
- absence of natural and artificial obstacles;
- the range of operation of small-sized radars – X-band (centimeter wavelength (from 2.5 cm to 3.75 cm));
- when conducting experimental calculations, cruise missiles of the KEPD-150/359 TAURUS (Germany-Sweden) and Kalibr (Russia) type, which have speeds of 0.6–0.95 M, are considered;
- the average effective scattering surface of cruise missiles of the KEPD-150/359 TAURUS (Germany-Sweden) and Kalibr (Russia) type is accepted from (0.4–0.6) sq.m to (1–1.5) sq.m in depending on the location of air objects relative to small-sized radars;
- the Monte Carlo method for statistical tests is used in the simulation.

When conducting experimental studies, the following were used:

- software: high-level programming language and interactive environment for programming, numerical calculations, and visualization of results MATLAB R2017b;
- software: high-level programming language Python 3.11;
- hardware: ASUSTeK COMPUTER INC model X550CC, 3rd Gen processor DRAM Controller – 0154, NVIDIA GeForce GT 720M.

### 5. Results of research on improving a method for detecting and measuring the coordinates of a stealth unmanned aerial vehicle

#### 5.1. Main stages of the method for detecting and measuring the coordinates of a stealth unmanned aerial vehicle

The network of two small-sized radars is shown in Fig. 1 (B is the distance (base) between radars) [9].

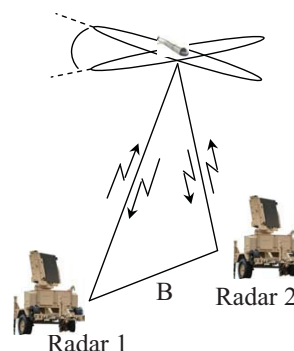

Fig. 1. A network of two small-sized radars [9]

Each small-sized radar emits a probing signal. These signals have the property of mutual orthogonality. The mathematical expression for the probing signal can be represented by expression (1):

$$\frac{1}{2} \int_{-\infty}^{\infty} I_{0_i}(t) I_{0_j}^*(t) dt = \begin{cases} 0, & i \neq j, \\ \tau_i, & i, j = \overline{1, 2}, \end{cases} \quad (1)$$

where  $I_{0_i}(t)$ ,  $I_{0_j}(t)$  are the envelopes of probing signals (complex, normalized) of the first and second small-sized radars;

$\tau_i$  – pulse duration;

\* is a symbol of complex conjugation.

Probing signals are reflected from a stealth unmanned aerial vehicle and enter the input of the receiving system of each small-sized radar. Moreover, each of the two small-sized radars can receive both its own reflected signal and the reflected signal from a stealth unmanned aerial vehicle emitted by another radar. This can be written in the form of expression (2):

$$I^*(t, \vec{\lambda}) = (I_1^*(t, \vec{\lambda}_1), I_2^*(t, \vec{\lambda}_2)), \quad (2)$$

where  $I(t, \vec{\lambda})$  is the set of receiving signals (echo signals) by each small-sized radar;

$I_1(t, \vec{\lambda}_1), I_2(t, \vec{\lambda}_2)$  – echo signal of the first and second small-sized radars.

Echo signals of the first and second ( $i=1; 2$ ) small radars can be described by expression (3):

$$I_i(t, \vec{\lambda}_i) = I_{s_i} e^{(-j\omega_{s_i} t)} I_{0_i}(t - t_{s_i}) e^{(j(\omega_0 + \Omega_{s_i})(t - t_{s_i}))}, \quad (3)$$

where  $I_{s_i}$  is the mathematical expectation;

$\vec{\lambda}_i$  – informative parameters of the signal, which are represented by the vector  $(\varphi_{s_i}, t_{s_i}, \Omega_{s_i}, \omega_{0_i})$ ;  $\varphi_{s_i}$  – initial phase of the signal in each small-sized radar;  $t_{s_i}$  – signal delay time in each small-sized radar;  $\Omega_{s_i}$  – Doppler correction to the frequency in each small-sized radar;  $\omega_{0_i}$  – signal carrier frequency in each small-sized radar;  $I_{0_i}(t - t_{s_i})$  – signal envelope (complex, normalized), which is determined by the modulation law in each small-sized radar.

Taking into account the conditions of coherent processing of the reflected signal from a stealth unmanned aerial vehicle, we shall write down the optimal detection algorithm. At the same time, we shall use the well-known Neyman-Pearson test [30]. So, the detection algorithm optimal according to the Neyman-Pearson criterion is represented by expression (4):

$$L = \left| \sum_{i=1}^2 \sum_{j=1}^2 e^{(j\omega_{0_i} \tau_{r_i})} e^{(j\omega_{0_j} \tau_{rec_j})} \int_{-\infty}^{\infty} I_{0_j}^*(t - t_0) x_i(t) dt \right| \begin{matrix} > \\ \leq \end{matrix} th, \quad (4)$$

where  $L$  is the likelihood ratio;  $\tau_{r_i}$ ,  $\tau_{rec_j}$  – time that takes into account the delay of the probing signal by the  $j$ -th small-sized radar at the input of the receiving device of the  $i$ -th small-sized radar ( $i, j=1; 2$ );  $th$  is the defined detection threshold.

In accordance with expression (4), the scheme of the detector of a stealth unmanned aerial vehicle optimal according to the Neyman-Pearson criterion by a network of two small-sized radars is shown in Fig. 2.

Taking into account expression (4) and Fig. 2, the main stages of the method for detecting a stealth unmanned aerial vehicle by a network of two small-sized radars are:

- reception of a signal reflected from a stealth unmanned aerial vehicle by two small-sized radars;
- carrying out coordinated filtering (UV) of input signals  $I_{0_j}^*(t - t_0)$ ;
- compensation of phase shifts and coherent addition of output signals from UV;
- formation of Doppler channels in each small-sized radar and formation of a complex envelope from the output of the corresponding Doppler channel;
- coherent processing (adding) of signals from two small radars;
- compensation of the random initial phase of signals reflected from a stealth unmanned aerial vehicle by detecting the output signal from the coherent adder.

Analyzing the above, we can conclude that the method for detecting a stealth unmanned aerial vehicle by a network of two small-sized radars involves directing the network to the area of the airspace with the most probable value of finding an aerial object.

To determine the coordinates of a stealth unmanned aerial vehicle using a network of two small-sized radars, we shall use a method from [9].

The main stages of the method in [9] are as follows:

1. Determining the distance from a small-sized radar to a stealth unmanned aerial vehicle using a range-finding method. These distances  $R_1, R_2$  are calculated according to expressions (5), (6), in line with [9]:

$$R_1 = 0.5ct_{z1}, \quad (5)$$

where  $c$  is the speed of light;  $t_{z1}$  is the delay time of the probing signal from radar 1:

$$R_2 = 0.5ct_{z2}, \quad (6)$$

where  $t_{z2}$  is the delay time of the probing signal from radar 2.

2. Calculation of the coordinates of a stealth unmanned aerial vehicle ( $x_{AO}, y_{AO}$ ) according to expressions (7), (8), in line with [9]:

$$x_{AO} = \frac{1}{2B} (R_1^2 - R_2^2), \quad (7)$$

$$y_{AO} = \frac{1}{2B} \sqrt{(2R_1^2 B^2 + 2R_2^2 B^2 + 2R_1^2 R_2^2 - R_1^4 - R_2^4 - B^4)}. \quad (8)$$

3. Checking the conditions for tracking a stealth unmanned aerial vehicle with two small-sized radars.

4. Determining the trajectory parameters of a stealth unmanned aerial vehicle.

The method for determining the coordinates of a stealth unmanned aerial vehicle by a network of two small-sized radars involves:

- synchronous inspection of the airspace by small-sized radars;
- measuring the range to a stealth unmanned aerial vehicle by each small-sized radar;
- calculation of the coordinates of a stealth unmanned aerial vehicle.

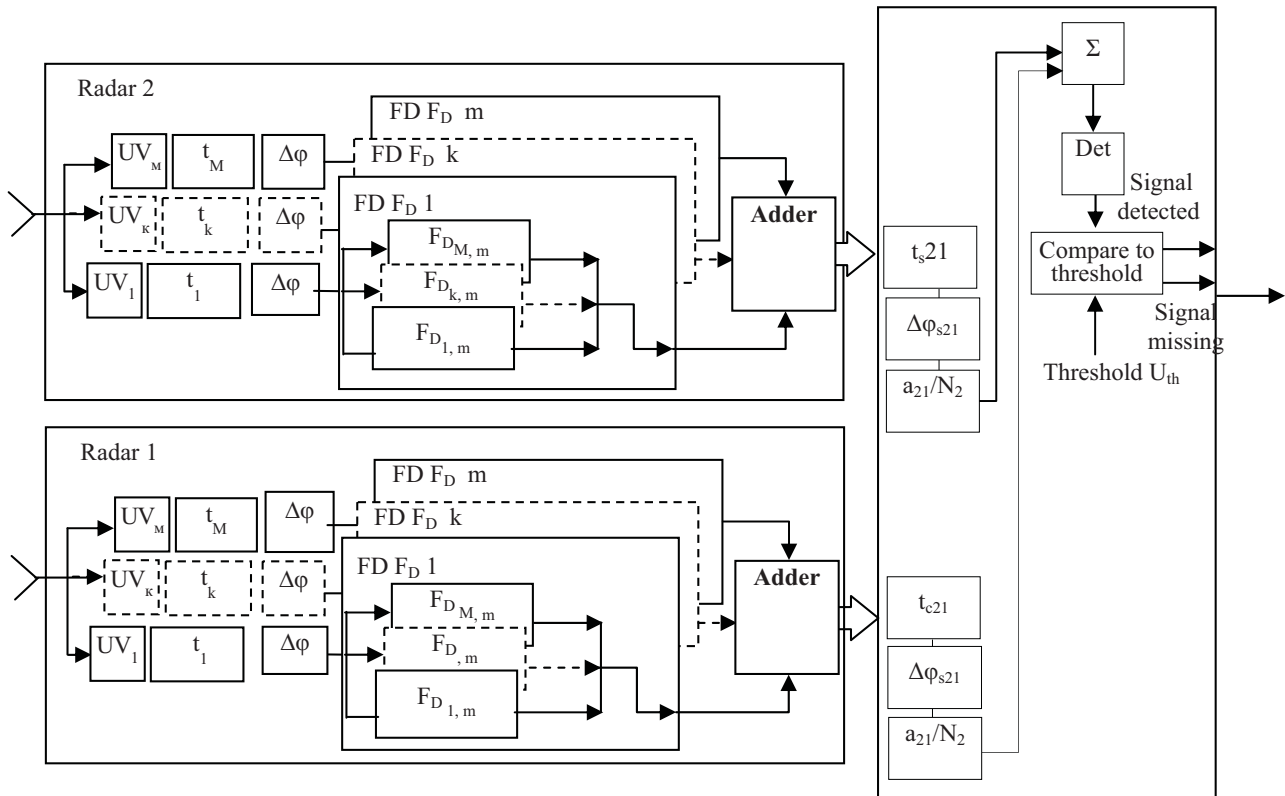

Fig. 2. Scheme of a detector of a stealth unmanned aerial vehicle by a network of two small-sized radars, optimal according to the Neyman-Pearson criterion

Thus, the improved method for detecting and determining the coordinates of a stealth unmanned aerial vehicle by a network of two small-sized radars involves:

- synchronous inspection of the airspace by small-sized radars;
- reception of a signal reflected from a stealth unmanned aerial vehicle by two small-sized radars;
- conduction of UV input signals;
- compensation of phase shifts and coherent addition of output signals from UV;
- formation of Doppler channels in each small-sized radar and formation of a complex envelope from the output of the corresponding Doppler channel;
- coherent processing (adding) of signals from two small radars;
- compensation of the random initial phase of signals reflected from a stealth unmanned aerial vehicle by detecting the output signal from the coherent adder;
- measuring the range to a stealth unmanned aerial vehicle by each small-sized radar;
- calculation of the coordinates of a stealth unmanned aerial vehicle.

**5. 2. Evaluation of the quality of detection and measurement of the coordinates of a stealth unmanned aerial vehicle by a network of two small-sized radars**

Evaluation of the quality of detection of a stealth unmanned aerial vehicle by a network of small-sized radars was carried out by calculating the conditional probability of correct detection. To this end, the initial statistics (likelihood ratio) were calculated in the presence of a usable signal. Taking into account (4), the likelihood

ratio in the presence of a usable signal is calculated by expression (9):

$$L = \sum_{i=1}^2 \sum_{j=1}^2 e^{(j\omega_j \tau_{r_{ij}})} e^{(j\omega_j \tau_{rec_j})} \int_{-\infty}^{\infty} I_{0_j}^*(t-t_0) x_i(t) dt. \tag{9}$$

The output statistic (likelihood ratio) in the absence of a usable signal is determined by expression (10):

$$L_0 = \sum_{i=1}^2 \sum_{j=1}^2 e^{(j\omega_j \tau_{r_{ij}})} e^{(j\omega_j \tau_{rec_j})} \int_{-\infty}^{\infty} I_{0_j}^*(t-t_0) n_i(t) dt, \tag{10}$$

where  $n_i(t)$  is a function describing the noise of each of the two small radars.

Subsequently, it was assumed that the noise amplitude is distributed according to the normal law under condition (11):

$$\frac{1}{2} \overline{n_i(t_1) n_j^*(t_2)} = N_0 \delta(t_1 - t_2) \delta_{ij}, \tag{11}$$

where  $\delta(t_1 - t_2)$  is the delta function;  $\delta_{ij}$  is the Kronecker symbol.

The variance of  $L_0$  value (expression (10)) is calculated from expression (12):

$$\frac{1}{2} \overline{L_0^2} = 8N_0 \tau_i. \tag{12}$$

The variance of  $L$  (expression (9)) is calculated according to expression (13):

$$\frac{1}{2} \overline{L^2} = 32 \overline{E_s} \tau_i. \tag{13}$$

The average value  $\overline{q_s^2}$  of the signal/noise is calculated. Taking into account (12), (13), we obtain expression (14):

$$\overline{q_s^2} = \frac{\frac{1}{2} \overline{L^* L}}{\frac{1}{2} \overline{L_0^* L_0}} = \frac{32 \overline{E_s} \tau_i}{8 N_0 \tau_i} = 4 q_s^2, \quad (14)$$

where  $q_s^2$  is the signal/noise ratio for one signal at the output of a small-sized radar.

Taking into account expression (14), the conditional probability of correct detection was calculated. The conditional probability of correct detection is calculated according to expression (15):

$$D = F \left( \frac{1}{1 + \overline{q_s^2}} \right), \quad (15)$$

where  $F$  is the conditional probability of a false alarm.

Fig. 3 shows constructed detection curves for the case of one radar (green curve) and for a network of two small-sized radars (blue curve).

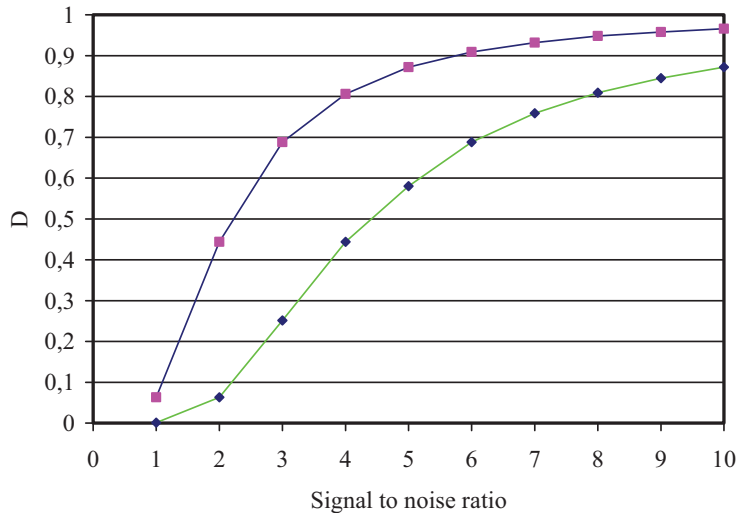

Fig. 3. Curves of detection of an aerial object by one radar (green curve) and a network of two small-sized radars (blue curve)

Fig. 3 shows the dependence of conditional probability of correct detection on the signal/noise ratio. The conditional probability of a false alarm was assumed to be  $F=10^{-6}$ .

Analysis of Fig. 3 reveals that the use of a network of two small-sized radars provides a gain in the value of the conditional probability of correct detection at a fixed value of the conditional probability of a false alarm. This gain is especially significant at low signal-to-noise values. At low signal-to-noise values, the gain in terms of the conditional probability of correct detection is from 25 % to 32 %.

The evaluation of the quality of determining the coordinates of a stealth unmanned aerial vehicle was carried out taking into account [9].

Fig. 4 shows the mean square values of errors in determining the coordinates of a stealth unmanned aerial vehicle by a network of two small-sized radars [9].

Analysis of Fig. 4 demonstrates that the use of a network of two small-sized radars makes it possible to reduce the mean square error in determining the coordinates of a stealth unmanned aerial vehicle by 28 % to 37 % on average.

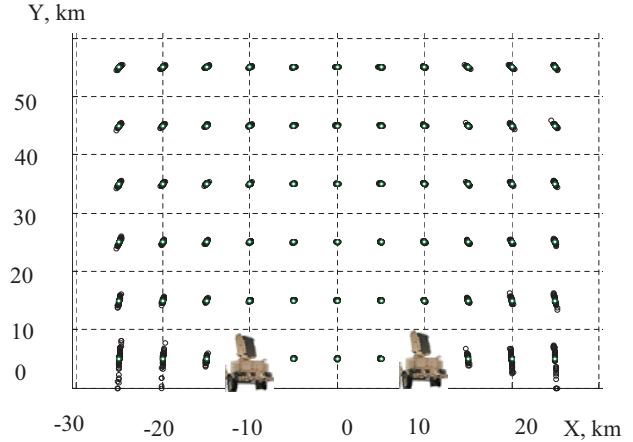

Fig. 4. Mean square errors in determining the coordinates of a stealth unmanned aerial vehicle by a network of two small-sized radars [9]

## 6. Discussion of research results on improving the method for detecting and measuring the coordinates of a stealth unmanned aerial vehicle

A mathematical expression for the likelihood ratio in the detection of a stealth unmanned aerial vehicle by a network of two small-sized radars was obtained (expression (4)). At the same time, the well-known Neyman-Pearson criterion was used as an optimality criterion. The scheme of the optimal detector of a stealth unmanned aerial vehicle with a network of two small-sized radars was built (Fig. 2).

The improved method for detecting and determining the coordinates of a stealth unmanned aerial vehicle by a network of two small-sized radars, unlike the known ones (for example, [10, 11]), enables:

- synchronous inspection of the airspace by small-sized radars;
- reception of a signal reflected from a stealth unmanned aerial vehicle by two small-sized radars;
- conduction of UV input signals;
- compensation of phase shifts and coherent addition of output signals from UV;
- formation of Doppler channels in each small-sized radar and formation of a complex envelope from the output of the corresponding Doppler channel;
- coherent processing (adding) of signals from two small radars;
- compensation of the random initial phase of signals reflected from a stealth unmanned aerial vehicle by detecting the output signal from the coherent adder;
- measuring the range to a stealth unmanned aerial vehicle by each small-sized radar;
- calculation of the coordinates of a stealth unmanned aerial vehicle.

A feature of the method is the use of two small-sized radars, which are connected in a network to detect and determine the coordinates of a stealth unmanned aerial vehicle.

The quality of detecting and measuring the coordinates of a stealth unmanned aerial vehicle by a network of two small-sized radars was evaluated. An expression for the initial statistics (likelihood ratio) in the presence of a usable signal is obtained (expression (9)). The expression for the

initial statistics (likelihood ratio) in the absence of a usable signal is determined (expression (10)). Expressions for the variance of the determined statistics were obtained (expressions (11) and (12), respectively). The average signal/noise value (expression (14)) and conditional probability of correct detection (expression (15)) were calculated. Detection curves are plotted for the case of one radar (green curve) and for a network of two small-sized radars (blue curve) (Fig. 3).

Analysis of Fig. 3 reveals that the use of a network of two small-sized radars provides a gain in the value of the conditional probability of correct detection at a fixed value of the conditional probability of a false alarm. This gain is especially significant at low signal-to-noise values. At low signal-to-noise values, the gain in the value of the conditional probability of correct detection, for example, in comparison with [10, 11], is from 25 % to 32 %.

Fig. 4 shows the mean square values of errors in determining the coordinates of a stealth unmanned aerial vehicle by a network of two small-sized radars. From the analysis of Fig. 4, it can be seen that the use of a network of two small-sized radars makes it possible to reduce the value of the mean square error in determining the coordinates of a stealth unmanned aerial vehicle, for example, in comparison with [10, 11], by, on average, 28 % to 37 %.

This study has the following limitations:

- small-sized radars must have digital signal processing;
- stable conditions for receiving a reflected signal from a stealth unmanned aerial vehicle must be ensured by each small-sized radar;
- inspection of the airspace by small-sized radars must necessarily be synchronous;
- the processing of the reflected signal from a stealth unmanned aerial vehicle must be coherent;
- restrictions on the absence of natural and artificial obstacles were imposed.

The disadvantage of the method for detecting and determining the coordinates of a stealth unmanned aerial vehicle by a network of two small-sized radars is that it does not take into account the case of incoherent processing of reflected signals.

Further research is aimed at taking into account the case of incoherence of signals reflected from a stealth aerial vehicle.

---

## 7. Conclusions

---

1. The improved method for detecting and determining the coordinates of a stealth unmanned aerial vehicle using a network of two small-sized radars involves:

- synchronous inspection of the airspace by small-sized radars;
- reception of a signal reflected from a stealth unmanned aerial vehicle by two small-sized radars;

- conduction of UV input signals;
- compensation of phase shifts and coherent addition of output signals from UV;
- formation of Doppler channels in each small-sized radar and formation of a complex envelope from the output of the corresponding Doppler channel;
- coherent processing (adding) of signals from two small radars;
- compensation of the random initial phase of signals reflected from a stealth unmanned aerial vehicle by detecting the output signal from the coherent adder.
- measuring the range to a stealth unmanned aerial vehicle by each small-sized radar;
- calculation of the coordinates of a stealth unmanned aerial vehicle.

2. The quality of detecting and measuring the coordinates of a stealth unmanned aerial vehicle by a network of two small-sized radars was evaluated. It was established that the use of a network of two small-sized radars provides a gain in the value of the conditional probability of correct detection at a fixed value of the conditional probability of a false alarm. This gain is especially significant at low signal-to-noise values. At low signal-to-noise values, the gain in terms of the conditional probability of correct detection is from 25 % to 32 %.

It was established that the use of a network of two small-sized radars makes it possible to reduce the mean square error in determining the coordinates of a stealth unmanned aerial vehicle by 28 % to 37 % on average.

---

## Conflicts of interest

---

The authors declare that they have no conflicts of interest in relation to the current study, including financial, personal, authorship, or any other, that could affect the study and the results reported in this paper.

---

## Funding

---

The study was conducted without financial support.

---

## Data availability

---

All data are available in the main text of the manuscript.

---

## Use of artificial intelligence

---

The authors confirm that they did not use artificial intelligence technologies when creating the presented work.

---

## References

1. Erl, J. (2022). Sensing digital objects in the air: Ultraleap introduces new technology. MIXED. Available at: <https://mixed-news.com/en/sensing-digital-objects-in-the-air-ultraleap-introduces-new-technology/>
2. Carafano, J. J. (2022). Rapid advancements in military tech. Available at: <https://www.gisreportsonline.com/r/military-technology/>
3. Kalibr. Naval Cruise missile family. Available at: <https://www.militarytoday.com/missiles/kalibr.htm>
4. Orlan-10 Uncrewed Aerial Vehicle (UAV) (2023). Available at: <https://www.airforce-technology.com/projects/orlan-10-unmanned-aerial-vehicle-uav/#catfish>
5. Chang, L. ZALA Lancet. Loitering munition. Available at: <https://www.militarytoday.com/aircraft/lancet.htm>

6. Sentinel Radar. URL: <https://www.rtx.com/raytheon/what-we-do/land>
7. NASAMS anti-aircraft missile system. Available at: <https://en.missilery.info/missile/nasams>
8. Chernyak, V. (2014). Signal detection with MIMO radars. Available at: [https://www.researchgate.net/publication/267613025\\_Signal\\_detection\\_with\\_MIMO\\_radars](https://www.researchgate.net/publication/267613025_Signal_detection_with_MIMO_radars)
9. Khudov, H., Berezhnyi, A., Oleksenko, O., Maliuha, V., Balyk, I., Herda, M. et al. (2023). Increasing of the accuracy of determining the coordinates of an aerial object in the two-position network of small-sized radars. *Eastern-European Journal of Enterprise Technologies*, 5 (9 (125)), 6–13. doi: <https://doi.org/10.15587/1729-4061.2023.289623>
10. Bezouwen, J., Brandfass, M. (2017). Technology Trends for Future Radar. Available at: <https://www.microwavejournal.com/articles/29367-technology-trends-for-future-radar>
11. Richards, M. A., Scheer, J. A., Holm, W. A. (Eds.) (2010). Principles of Modern Radar: Basic principles. IET. doi: <https://doi.org/10.1049/sbra021e>
12. Lishchenko, V., Kalimulin, T., Khizhnyak, I., Khudov, H. (2018). The Method of the organization Coordinated Work for Air Surveillance in MIMO Radar. 2018 International Conference on Information and Telecommunication Technologies and Radio Electronics (UkrMiCo). doi: <https://doi.org/10.1109/ukrmico43733.2018.9047560>
13. Khudov, H. (2020). The Coherent Signals Processing Method in the Multiradar System of the Same Type Two-coordinate Surveillance Radars with Mechanical Azimuthal Rotation. *International Journal of Emerging Trends in Engineering Research*, 8 (6), 2624–2630. doi: <https://doi.org/10.30534/ijeter/2020/66862020>
14. Neyt, X., Raout, J., Kubica, M., Kubica, V., Roques, S., Acheroy, M., Verly, J. Feasibility of STAP for passive GSM-based radar. Available at: <https://citeseerx.ist.psu.edu/viewdoc/download?doi=10.1.1.158.2101&rep=rep1&type=pdf>
15. Willis N. J., Nicholas, J. (2005). Bistatic Radar. Raleigh: SciTech Publishing. Available at: <https://dokumen.tips/documents/bistatic-radar-second-edition.html?page=3>
16. Lishchenko, V., Khudov, H., Tiutiunyyk, V., Kuprii, V., Zots, F., Misiyuk, G. (2019). The Method of Increasing the Detection Range of Unmanned Aerial Vehicles In Multiradar Systems Based on Surveillance Radars. 2019 IEEE 39th International Conference on Electronics and Nanotechnology (ELNANO). doi: <https://doi.org/10.1109/elnano.2019.8783263>
17. Ruban, I., Khudov, H., Lishchenko, V., Pukhovyi, O., Popov, S., Kolos, R. et al. (2020). Assessing the detection zones of radar stations with the additional use of radiation from external sources. *Eastern-European Journal of Enterprise Technologies*, 6 (9 (108)), 6–17. doi: <https://doi.org/10.15587/1729-4061.2020.216118>
18. LORAN-C. Available at: <https://skybrary.aero/articles/loran-c>
19. Multilateralism (MLAT) Concept of Use, Edition 1.0 (2007). International Civil Aviation Organization Asia And Pacific Office. Available at: [https://www.icao.int/APAC/Documents/edocs/mlat\\_concept.pdf](https://www.icao.int/APAC/Documents/edocs/mlat_concept.pdf)
20. Neven, W. H., Quilter, T. J., Weedon, R., Hogendoorn, R. A. Wide Area Multilateralism Wide Area Multilateralism Report on EATMP TRS 131/04. Available at: <https://www.eurocontrol.int/sites/default/files/2019-05/surveillance-report-wide-area-multilateralism-200508.pdf>
21. Mantilla-Gaviria, I. A., Leonardi, M., Balbastre-Tejedor, J. V., de los Reyes, E. (2013). On the application of singular value decomposition and Tikhonov regularization to ill-posed problems in hyperbolic passive location. *Mathematical and Computer Modelling*, 57 (7-8), 1999–2008. doi: <https://doi.org/10.1016/j.mcm.2012.03.004>
22. Schau, H., Robinson, A. (1987). Passive source localization employing intersecting spherical surfaces from time-of-arrival differences. *IEEE Transactions on Acoustics, Speech, and Signal Processing*, 35 (8), 1223–1225. doi: <https://doi.org/10.1109/tassp.1987.1165266>
23. Ryu, H., Wee, I., Kim, T., Shim, D. H. (2020). Heterogeneous sensor fusion based omnidirectional object detection. 2020 20th International Conference on Control, Automation and Systems (ICCAS). doi: <https://doi.org/10.23919/iccas50221.2020.9268431>
24. Salman, S., Mir, J., Farooq, M. T., Malik, A. N., Haleemdeen, R. (2021). Machine Learning Inspired Efficient Audio Drone Detection using Acoustic Features. 2021 International Bhurban Conference on Applied Sciences and Technologies (IBCAST). doi: <https://doi.org/10.1109/ibcast51254.2021.9393232>
25. Yuqi, L., Jianxin, Y., Xianrong, W., Feng, C., Yunhua, R. (2018). Experimental Research on Micro-Doppler Effect of Multi-rotor Drone with Digital Television Based Passive Radar. *Journal of Radars*, 7 (5), 585–592. doi: <https://doi.org/10.12000/JR18062>
26. Wang, W. (2016). Overview of frequency diverse array in radar and navigation applications. *IET Radar, Sonar & Navigation*, 10 (6), 1001–1012. doi: <https://doi.org/10.1049/iet-rsn.2015.0464>
27. Li, J., Stoica, P. (Eds.) (2008). MIMO Radar Signal Processing. John Wiley & Sons, Inc. doi: <https://doi.org/10.1002/9780470391488>
28. Li, Y. (2021). MIMO Radar Waveform Design: An Overview. *Journal of Beijing Institute of Technology*, 30 (1), 44–59. doi: <https://doi.org/10.15918/j.jbit1004-0579.2021.002>
29. Oleksenko, O., Khudov, H., Petrenko, K., Horobets, Y., Kolianda, V., Kuchuk, N. et al. (2021). The Development of the Method of Radar Observation System Construction of the Airspace on the Basis of Genetic Algorithm. *International Journal of Emerging Technology and Advanced Engineering*, 11 (8), 23–30. doi: [https://doi.org/10.46338/ijetae0821\\_04](https://doi.org/10.46338/ijetae0821_04)
30. Shin, S.-J. (2017). Radar measurement accuracy associated with target RCS fluctuation. *Electronics Letters*, 53 (11), 750–752. doi: <https://doi.org/10.1049/el.2017.0901>