

Ekaterina Andreeva (Russia), Andrey Nechaev (Russia)

The improvement of the organization of innovation enterprise operational business processes using various forms of financing

Abstract

The article analyzes the improvement of the organization of the operational business processes in consideration of the use of various forms of financing innovation enterprise. It was prompted the author's definition of improving the organization of the operational business processes of innovation enterprise using various forms of financing used at appropriate stages of business processes, as well as operating system to improve the organization of business processes.

The authors present an innovative algorithm for calculating the costs of operating stages of the business process using the basic forms of financing innovation, which is given on the basis of an innovative method of calculating the cost for each phase of operations of an innovative enterprise.

Keywords: operational business processes, enterprise innovation, an innovative algorithm, calculation of costs, improve the system, innovative tools.

JEL Classification: E62, O31.

Introduction

There is no clear definition of the improving the organization of the innovation enterprise operational business processes in foreign and Russian economic literature at the moment.

Many of the world's leading economists offer the definitions and interpretations of concepts that are similar in meaning and content.

For example, James Harrington understood the improving business process as the methodology, which was developed for incremental improvements in administrative, and support processes using the technique of rapid analysis solutions, bench-marking and re-engineering processes (Harrington, Esseling, Nimvegen, 2002).

According to some economists (Bjorn, 2003; Goldratt, Cox, 2009; Kotler, Berger, Bikhoff, 2012; Guoting, Kalosha, 2007) the improving business processes is a structured approach to analyzing and streamlining management processes of all major spheres of life of the modern enterprise with the purpose of increasing the efficiency of individual business processes and activities of the enterprise on the whole.

1. Results

Proceeding from the above-mentioned interpretations, we formulate the author's definition of improving the organization of the innovation enterprise operational business processes using various forms of financing that are used at appropriate stages of business processes.

Improving the organization of innovation enterprise operational business processes using various forms of financing used at appropriate stages of the

business process – a set of activities designed to analyze and streamline business processes, create the main stream of income from operating activities of the enterprise associated with the development and implementation of new products, services, processes and other types of innovative activity by applying a structured approach and different forms of financing used at appropriate stages of operational business processes to improve the effectiveness of individual business processes and activities of the enterprise as a whole. The result of perfection is to achieve the maximum effect of production and economic and financial-economic activity of innovative enterprise.

The essence of a structured approach to the analysis and rationalization of business processes is the separation of the analyzed system and the hierarchical organization of these parts (Nechaev, Starkov, 2013; Nechaev, 2010).

Definition proposed by the author to improve the organization of the operational business processes of an innovative enterprise, unlike represented in most scientific and practical research, focuses on the need for effective use of the structural approach in combination with various forms of financing innovation enterprise.

It should be noted that the advantage of using a structured approach to analyze and streamline operational business processes of innovation-oriented enterprises is that the need to obtain detailed information about the work of the business processes that are absent, have enough information about their inputs and outputs, as well as functions that they perform. A combined use of a structured approach and different forms of financing innovation will achieve maximum effect in improving the organization of an innovation enterprise operational business processes.

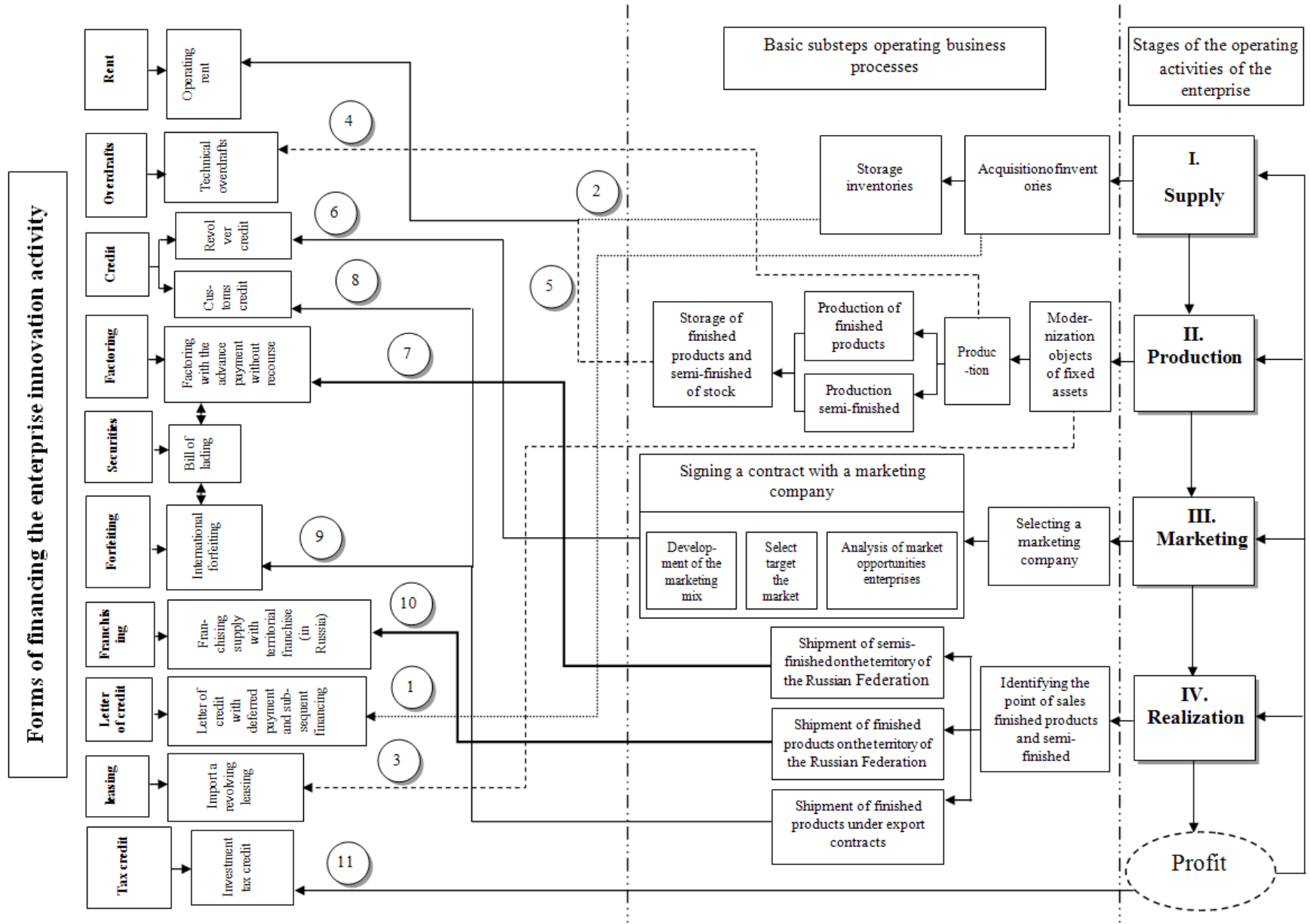

Fig. 1. System to improve the organization of the operational business processes based on the use of various forms of financing the enterprise's innovation activity

Financing system innovation is a complex interweaving of forms and methods that differ in the directions of use, providing the conditions and other parameters. However, the general point is that the use of these forms and methods certainly contributes to the improvement of existing approaches to operational business processes in innovative projects (Kokurin, Agabeyov, Nazin, 2011).

We proposed a system to improve the organization of the operational business processes based on the using of various forms of financing innovation enterprise (Figure 1).

This system makes it possible to study the use of various forms of financing innovation enterprise in accordance with the stages of operational business processes that enable the company to build business competently and get the most out of an innovative project.

The system is used:

1. Application of credit with deferred payment and subsequent financing in order to obtain funds for the purchase of inventory. The company is a manufacturer which has no own funds to purchase inventory, not only gets the necessary funding, but also gets an additional term for repayment of debt to the bank.
2. Application of operational lease for the purpose of warehouse rent registration for storage of inventory. First, the operating lease is not reflected in the balance of assets and liabilities, thereby avoiding the company of debt. Secondly, the costs of operating leases are simple rents paid evenly over the life of the leased asset.
3. Application of imported revolving lease to upgrade fixed assets. With imported revolving leasing company will be able to purchase the necessary innovation-oriented industrial fixed assets abroad.
4. Drawing technical overdraft in order to obtain funds to purchase equipment for the manufacture of semi-finished and finished products. Technical overdraft is the most appropriate form of financing for innovation-oriented enterprises, as available, excluding the financial condition of the client as decorated at his expense guaranteed payment.
5. Application of operational lease for the purpose of warehouse rent registration for storage of finished and semi-finished products (see paragraph 2).
6. Registration of a revolving credit facility in order to obtain funds to pay for service marketing company. Payment services marketing company is periodic, and that is the main criterion for choosing this form of financing.
7. Using factoring advance payment without recourse to introduce implementation semis in Russia. This form of financing allows you to get from the factoring company down payment to 90% of the amount of money requirements before the buyer (debtor) completely transfer money to the account of the factoring company for the delivered goods. Factoring without recourse means that in case of insolvency of the debtor, the factoring company will suffer losses and not the lender. When using factoring advance payment without recourse it is possible to use a bill of lading issued by the carrier to the cargo-shipping company certifying the goods for carriage and having to deliver the goods at the destination and send it to the recipient.
8. Customs clearance of the loan in order to obtain funds for the implementation of shipment for export contracts. This form of financing allows to defer payment of customs duties provided for guarantee and payment of interest on the amount payable for the period of deferment.
9. Use of international forfaiting in order to profit from the sale of its products abroad. In this case the company-manufacturer favorably conclude export contracts for the supply of its products abroad, acting as a lender, while yielding debt from the debtor in the form of promissory notes, accounts receivable and other securities. When using international forfaiting it is possible to use a bill of lading, which is the carriage of goods, and can also serve as collateral for a loan under the shipped goods.
10. Application for Sales franchising territorial franchise in order to obtain funds from the sale of franchises in the territory of the Russian Federation. This type of franchising is used in commerce to purchase the finished product in a particular territory and represents a distribution system sales of goods manufactured by the franchisor.
11. Registration of an investment tax credit for the purpose of obtaining income installment payments of tax on business profits. Implementation of innovation is a direct basis for obtaining such a loan, which would substantially reduce the amount of payments for income tax and thereby stimulate innovation and research activities of the enterprise.

Thus, the use of these forms of financing innovation enterprise, is the most appropriate depending on the stage of the business process, and contributes to both improve the organization of operational business processes, and the rapid and effective implementation of innovations and their subsequent commercialization, ensuring the growth of the financial impact of innovation the enterprise.

Today the number of innovation-oriented enterprises to actively growing at the same time increases and the need to attract long-term investments in order to increase production, purchasing the latest equipment and technological innovation (Nechaev, 2012).

To meet all the financial needs of the company and to solve the problem of financing innovation, you first need to select the basic forms of financing innovative projects of Steps operational business

processes and calculate all the expected costs when using these forms of financing.

Figure 2 presents an innovative algorithm for calculating the costs of operating stages of the business process using the basic forms of financing innovation (operating lease, technical overdraft, customs and revolving credit, factoring, international forfeiting sales franchise, with installment credit payment, leasing and import revolving investment tax credit).

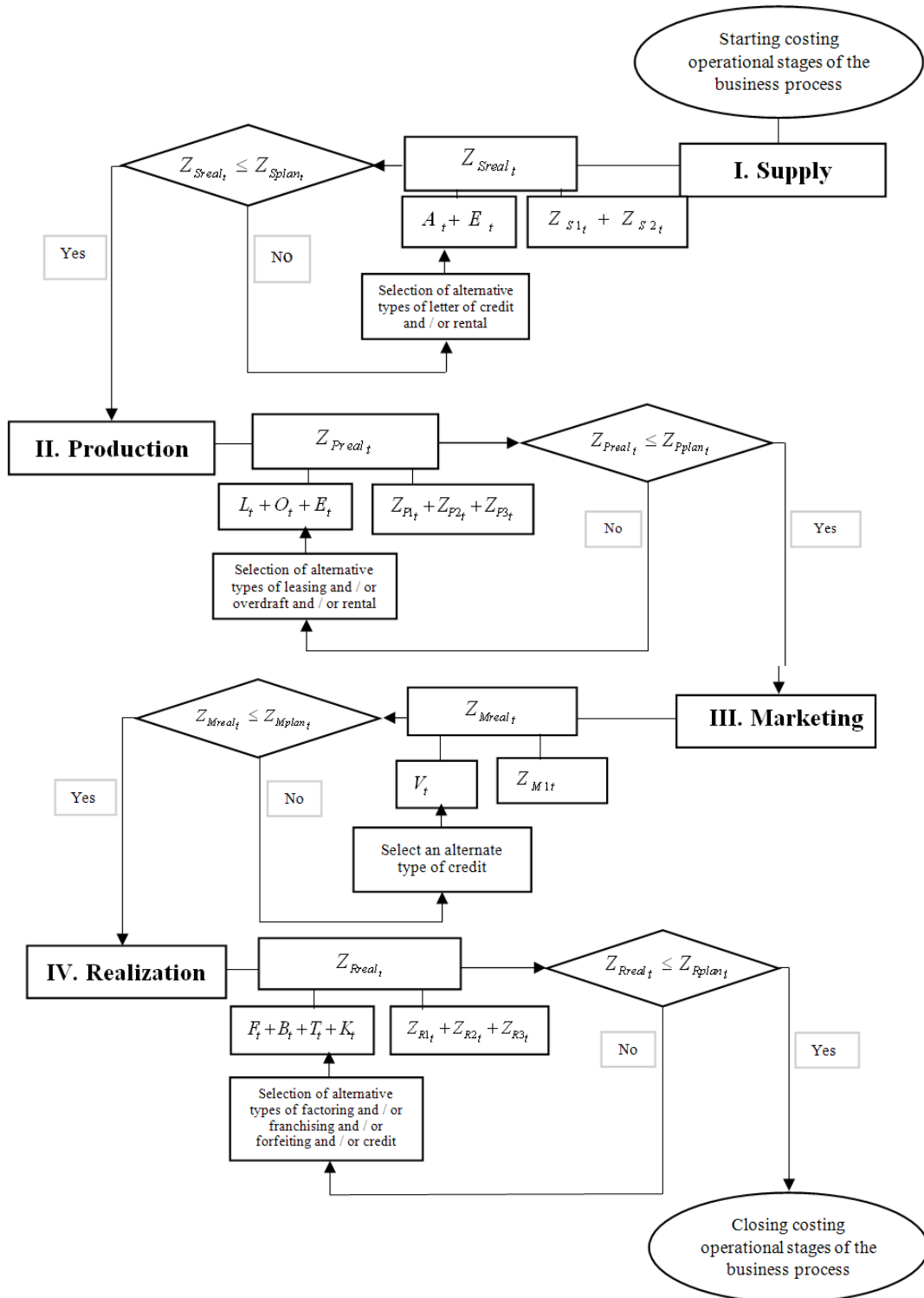

Fig. 2. Algorithm for calculating the operating costs of a business process using main forms of financing innovation

Explanation:

Stage I. Supply. The real amount of costs Z_{Sreal_t} in the first stage of the operational business process is the sum of costs of using letters of credit financing A_t and of the cost of using the exploitation rental E_t , as well as the cost of an substep operating business process “supply” (Z_{S1_t}, Z_{S2_t}).

Thus, if the real amount of costs Z_{Sreal_t} is less than or equal to the planned Z_{Splan_t} , the data are acceptable forms of financing and are used on the stage of “Supply”. Otherwise, go back to the choice of the alternative types of letters of credit and/or rental.

Stage II. Production. The real amount of costs Z_{Preal_t} in the second stage of the operational business process consists of the sum of costs of using imported revolving lease L_t of the cost of using technical overdraft O_t amount and costs of using the exploitation rental E_t , as well as the cost of an operating substep of the business process “Production” ($Z_{P1_t}, Z_{P2_t}, Z_{P3_t}$).

Thus, if the real amount of costs Z_{Preal_t} is less than or equal to the planned Z_{Pplan_t} , the data are acceptable forms of financing and are used on the stage of “production”. Otherwise, go back to the choice of the alternative types of leasing and/or overdraft and/or rental.

Stage III. Marketing. The real amount of costs Z_{Mreal_t} in the third stage of the operational business process consists of the sum of costs of using revolving credit V_t and the cost of an operating sub-step business process “Marketing” (Z_{M1_t}).

Thus, if the real amount of costs Z_{Mreal_t} is less than or equal to the planned Z_{Mplan_t} , this form of financing is acceptable and is used at “Marketing”. Otherwise, go back to the choice of an alternative form of crediting.

Stage IV. Realization. The real amount of costs Z_{Rreal_t} in the fourth stage of the operational business process consists of the sum of costs of using factoring advance payment without recourse F_t , of the cost of using the sales franchising territorial franchise K_t , of the cost of using an international forfeiting B_t and customs crediting T_t , as well as the cost of an operating sub-step business process “Implementation” ($Z_{R1_t}, Z_{R2_t}, Z_{R3_t}$).

Thus, if the real amount of costs Z_{Rreal_t} is less than or equal to the planned Z_{Rplan_t} , the data are acceptable forms of financing and used in step “Realization”.

Otherwise, go back to the choice of the alternative types of factoring and/or franchising and/or forfeiting and/or crediting.

This algorithm allows the company to calculate the costs at each stage of the operational business process associated with the use of basic forms of financing that will allow the maximum benefit from the economic point of view, select the appropriate view of a particular form of financing in accordance with the stage of operations of an innovative enterprise.

The role and importance of innovation in today's economy of our state are sufficiently large. This aspect is fundamental in determining the need for an integrated approach to the identification of key areas, forms and methods of development of the economic potential of an enterprise engaged in innovative activities that can be implemented in the concept of development and improvement of the financial and organizational mechanism operational business process innovation projects in the enterprise (Gluschenko, 2006).

At the present stage of development of our country, the increase of economic potential depends on the use of economic, organizational and managerial innovation in the economy (Ognyov, Nechaev, Dubinin, 2006).

In this regard, we need to develop financial and institutional mechanisms for operational business process innovation projects in the enterprise, based on the application of the process approach to the management of innovation-oriented enterprise, as well as the use of different forms of innovation enterprise financing.

First, create an innovative methodology for calculating the costs of using different forms of financing for each phase of operations of an innovative enterprise.

The creation of such tools will enable domestic innovative enterprises calculate in advance the financial costs associated with the financing of innovation at every stage of the transaction process. This will allow the company to more realistically assess their capabilities in the implementation of some of the innovative project.

In this case, the decision of the above-described problems will also contribute to building and strengthening the innovation capacity of enterprises of the country with innovative and improve their innovative activity. Imagine the following basic formula in Figure 3.

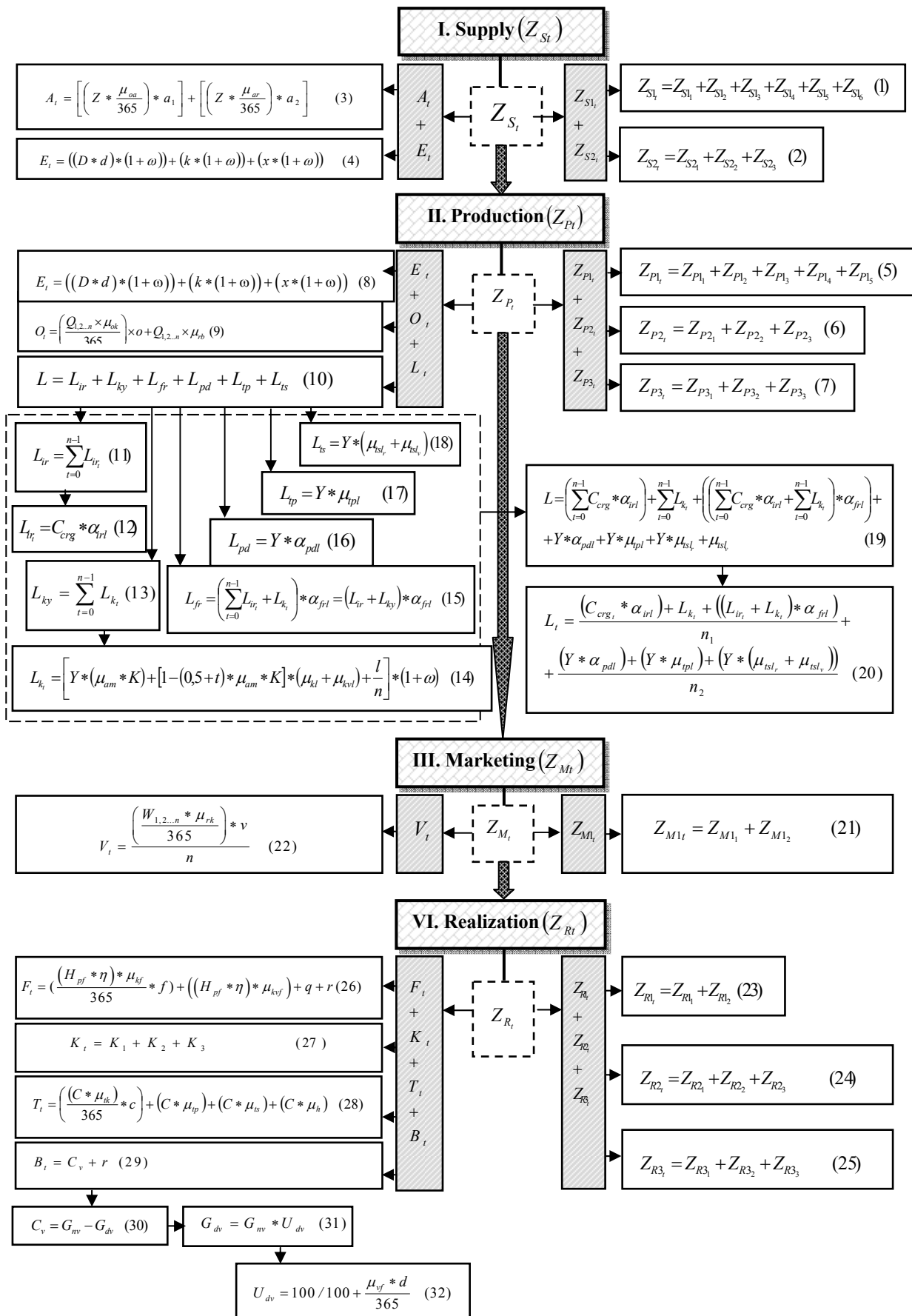

Fig. 3. Scheme for calculating the costs of using different forms of financing for each phase of operations of an innovative enterprise

Table 1. The notation for Fig. 3

Stage I. Supply			
Substep: "The acquisition of inventories" (Formula 1)			
Conventional designation	Explanation conventional designation	Conventional designation	Explanation conventional designation
Z_{S1_t}	amount of costs in substep "The acquisition of inventories" (m.u.);	Z_{S1_6}	payment wages to workers considering insurance contributions to extra-budgetary funds (m.u.);
t	calculating costs period (month);	Z_{S1_4}	payment of containers and packing (m.u.);
Z_{S1_1}	cost of raw materials (m.u.);	Z_{S1_5}	cargo insurance payment (m.u.);
Z_{S1_2}	payment of transport charges (m.u.);	Z_{S1_3}	payment forwarding services (m.u.).
Substep "Storage inventories" (Formula 2)			
Z_{S2_t}	amount of costs in substep "Storage inventories" (m.u.);	Z_{S2_2}	cost of of overalls and household inventory (m.u.);
t	calculating costs period (month);	Z_{S2_3}	payment wages to workers considering insurance contributions to extra-budgetary funds (m.u.).
Z_{S2_1}	payment machines and mechanisms (m.u.);	Z_{S2_3}	
Form of financing at the given stage: "Letter of credit" (Formula 3)			
A_t	amount of costs using letters of credit form of payment (m.u.);	μ_{oa}	interest rate per opening of a letter of credit (includes premium issuing bank for credit risk) (shares);
t	crediting period when used letters of credit form of payment (month);	a_1	quantity of days being equal the period from the date of opening of letter of credit prior to the date of payment by letter of credit in favor of the beneficiary (seller) (days);
μ_{ar}	interest rate on the funding period when used letters of credit (share);	a_2	quantity of days being equal the period from the date of of payment by letter of credit customer until full repayment of debt owed to the bank on the loan (days).
Z	value of the acquired inventories (m.u.);		
Form of financing at the given stage: "Rent" (Formula 4)			
E_t	amount of costs using operational orenda (m.u.);	d	conditional cost per square meter in month including revaluations, adjusted to the location and the comfortableness the leasedobject (m.u.);
t	calculating costs period (month);	x	maintenance payments (m.u.);
D	total usable area of the leased object (square meters);	ω	VAT (shares).
k	utility payments (m.u.);		
Stage II. Production			
Substep: "Modernization objects of fixed assets" (Formula 5)			
Z_{P1_t}	amount of costs in substep "Modernization objects of fixed assets" (m.u.);	Z_{P1_3}	payment forwarding services (m.u.);
t	calculating costs period (month);	Z_{P1_4}	payment of containers and packing (m.u.);
Z_{P1_1}	price of fixed assets (m.u.);	Z_{P1_5}	payment wages to workers considering insurance contributions to extra-budgetary funds (m.u.).
Z_{P1_2}	defrayal of the cost (m.u.);		
Substep: "Production of finished and semi-finished products" (Formula 6)			
Z_{P2_t}	amount of costs in substep "Production of finished and semi-finished products" (m.u.);	Z_{P2_2}	payment of containers and packing (m.u.);
t	calculating costs period (month);	Z_{P2_3}	payment wages to workers considering insurance contributions to extra-budgetary funds (m.u.).
Z_{P2_1}	utility payments (m.u.);		
Substep: "Storage of finished products and semi-finished of stock" (Formula 7)			
Z_{P3_t}	amount of costs in substep "Storage of finished products and semi-finished of stock" (m.u.);	Z_{P2_2}	cost of of overalls and household inventory (m.u.);
t	calculating costs period (month);	Z_{P3_3}	payment wages to workers considering insurance contributions to extra-budgetary funds (m.u.).
Z_{P3_1}	payment machines and mechanisms (m.u.);		
Form of financing at the given stage: "Leasing" (Formula 10-20)			
L	the total sum of costs using of imported revolver leasing for the entire period of the lease agreement (m.u.);	C_{nt}	residual value of fixed assets of the beginning t-th a year of operation (m.u.);
t	calculating costs period (year);	μ_{am}	depreciation rate (share).

Table 1 (cont.). The notation for Fig. 3

Form of financing at the given stage: "Leasing" (Formula 10-20)			
Conventional designation	Explanation conventional designation	Conventional designation	Explanation conventional designation
C_{crg_t}	average annual value of of leasing property in the t-th year of exploitation (m.u.);	K	acceleration factor (share);
α_{ir_l}	interest rate insurance payment on the property risk (share);	C_{kt}	residual value of fixed assets of the end t-th a year of operation (m.u.);
L_{k_t}	the amount leasing payment in the t-th year of exploitation (m.u.);	μ_{kl}	interest rate loan when using revolver leasing (share);
L_{ir_t}	the amount insurance payment on the property risk in the t-th year of exploitation (m.u.);	μ_{kvl}	interest rate commission fee for the lessor when the form of financing leasing (share);
α_{fr_t}	interest rate insurance payment for financial risk (share);	l	expenses for additional services for the entire period of the lease agreement (m.u.);
Y	cost of subject of leasing (m.u.);	ω	VAT (shares);
α_{pdl}	interest rate insurance payment for the equipment delivery period (share);	L_t	the amount costs using of imported revolver leasing for 1 month. in a t-th period of operation (m.u.);
μ_{tpl}	interest rate equipment export duty (share);	n_1	the amount of the lease payments per year;
μ_{tsl_r}	interest rate customs duty on equipment export in rubles (share);	n_2	the number of payments for the entire period of the lease agreement;
μ_{tsl_v}	interest rate of customs fees when exports of equipment in foreign currency (share);	L_{pd}	the amount of insurance coverage for the period of delivery of equipment (m.u.);
L_{tp}	the amount export customs duties on equipment (m.u.);	L_{ir}	the amount of insurance coverage on the property risk for the entire period of the lease agreement(m.u.);
L_{ky}	the amount leasing payment for the entire period of the lease agreement (m.u.);	L_{fr}	the amount of insurance coverage on the financial risk for the entire period of the lease agreement (m.u.).
L_{ts}	the amount of customs charges upon exports of equipment (m.u.);		
Form of financing at the given stage: "Overdrafts" (Formula 9)			
O_t	the sum of all costs using of funds from overdraft limit (m.u.);	μ_{ok}	interest rate when the overdraft crediting (share);
t	crediting period when used overdraft crediting (month);	μ_{rb}	expenses of the bank on carrying out transaction overdraft crediting (share);
$Q_{1,2...n}$	the amount used means trenches technical overdraft (m.u.);	o	quantity of days being equal loan period when the overdraft crediting (days).
Form of financing at the given stage: "Rent" (Formula 8)			
See transcript of symbols in the form of financing "Rent" on stage: I. "Supply"			
Stage III. Marketing			
Substep "Signing a contract with a marketing company" (Formula 21)			
Z_{M1_t}	amount of costs in substep "Signing a contract with a marketing company" (m.u.);	Z_{M1_t}	payment wages to workers considering insurance contributions to extra-budgetary funds (m.u.);
t	calculating costs period (month);	Z_{M1_2}	lawyer fee in the contract with a marketing company (m.u.).
Form of financing at the given stage: "Revolving Credit" (Formula 22)			
V_t	amount of costs using revolving credit (m.u.);	μ_{rk}	interest rate when the revolving crediting (share);
t	crediting period when used revolving credit (month);	v	quantity of days being equal loan period when the revolving crediting (days);
$W_{1,2...n}$	the amount revolving credit tranches (m.u.);	n	the number of payments during the whole loan agreement by means of revolving credit (pieces).
Stage IV. Realization			
Substep: "Shipment of semi-finished on the territory of the Russian Federation" (Formula 23)			
Z_{R1_t}	amount of costs in substep "Shipment of semi-finished products on the territory of the Russian Federation" (m.u.);	Z_{R1_t}	payment wages to workers considering insurance contributions to extra-budgetary funds (m.u.);
t	calculating costs period (month);	Z_{R1_2}	payment of containers and packing (m.u.).
Substep: "Shipment of products on the territory of the Russian Federation" (Formula 24)			
Z_{R2_t}	amount of costs in substep "Shipment of products on the territory of the Russian Federation" (m.u.);	Z_{R2_2}	cargo insurance payment (m.u.);
t	calculating costs period (month);	Z_{R2_3}	payment wages to workers considering insurance contributions to extra-budgetary funds (m.u.).
Z_{R2_1}	defrayal of the cost (m.u.);		

Table 1 (cont.). The notation for Fig. 3

Substep: "Shipment of products under export contracts" (Formula 25)			
Conventional designation	Explanation conventional designation	Conventional designation	Explanation conventional designation
Z_{R3_1}	amount of costs in substep "Shipment of products under export contracts" (m.u.);	Z_{R3_2}	cargo insurance payment (m.u.);
t	calculating costs period (month);	Z_{R3_3}	payment wages to workers considering insurance contributions to extra-budgetary funds (m.u.).
Z_{R3_1}	defrayal of the cost (m.u.);		
Form of financing at the given stage: "Factoring" (Formula 26)			
F_t	the amount costs using factoring with the advance payment without recourse (m.u.);	f	quantity of days being equal loan period when the factoring (days);
t	calculating costs period (month);	μ_{kf}	interest rate on the commission fee when factoring (share);
H_{pf}	cost selling of inventory holdings on the territory of the Russian Federation (m.u.);	q	the amount of commission for consideration of documents exporter when of the factoring form of funding (m.u.);
η	share available funds at the initial time when the factoring the form of funding (share);	r	the amount transportation costs, includes commission for issuing the bill of lading (m.u.).
μ_{kf}	interest rate on the loan when the factoring the form of funding (share);		
Form of financing at the given stage: "Franchising" (Formula 27)			
K_2	the amount the costs of advertising and promotion of the franchise (m.u.);	K_t	the amount costs using franchising territorial franchise (in Russia) (m.u.);
t	crediting period when using franchising (month);	K_1	the amount costs for salaries hired a consultant to develop a franchise package (m.u.).
K_3	the amount the costs of training and support for franchisees (m.u.);		
Form of financing at the given stage: "Customs credit" (Formula 28)			
T_t	the amount costs using custom credit (m.u.);	μ_{tk}	interest rate customs credit (share);
C	custom credit the amount (m.u.);	μ_{tp}	interest rate of export duty for customs crediting (share);
t	crediting period when using custom credit (month);	μ_{ts}	interest rate of customs fees for customs crediting (share);
c	quantity of days lending by means of custom credit (days);	μ_h	interest rate to pay fees accompaniment, registration and storage in a customs warehouse (share).
Form of financing at the given stage: "Forfaiting" (Formula 29-32)			
B_t	the amount costs when using international forfaiting (m.u.);	μ_{vf}	interest rate promissory notes when forfaiting form of financing (interest);
t	calculating costs period (month);	d	quantity of days appeal promissory notes (days);
C_v	the amount costs when selling promissory notes for exported products (m.u.);	G_{nv}	nominal value of the bill for exported products (m.u.);
G_{dv}	discounted price of promissory notes for exported products (m.u.);	r	the amount transportation costs, includes commission for issuing the bill of lading (m.u.).
U_{dv}	discount under the bill when the form of financing forfaiting (m.u.);		

Explanations:

Formula (1) calculates the sum of enterprise costs associated with the acquisition of inventories consisting of the cost of materials, transport costs, freight forwarding services, packaging, shipping and insurance payment wages to workers based on insurance premiums to extra-budgetary funds.

Formula (2) calculates the sum of enterprise costs associated with the storage of inventory, consisting of payment of machinery, coveralls, hardware inventory and payment wages to workers based on insurance premiums to extra-budgetary funds.

Formula (3) calculates the sum of the cost of the enterprise by using a letter of credit with deferred

payment and subsequent funding. This amount includes the costs associated with the opening of a letter of credit and the amount of interest on the loan in the form of a letter of credit financing.

Formula (4) calculates the sum of the cost of the enterprise by using operating leases. This amount includes the cost rent, utilities and maintenance fees and VAT charges.

Formula (5) calculates the sum of enterprise costs associated with upgrading the objects fixed assets, consisting of the cost of objects fixed assets, pay transportation costs, freight forwarding services, packing and packaging and payment wages to workers based on insurance premiums to extra-budgetary funds.

Formula (6) calculates the amount of enterprise costs associated with the production of finished products and semi-finished products, consisting of the payment of utilities and packaging machinery and payment wages to workers based on insurance premiums to extra-budgetary funds.

Formula (7) calculates the sum of enterprise costs associated with the storage of finished and semi-finished products in stock, consisting of payment of machinery, coveralls, hardware inventory and payment wages to workers based on insurance premiums to extra-budgetary funds.

Formula (8) – see explanation of Formula (4).

Formula (9) calculates the sum of the cost of the enterprise by using technical overdraft. This amount includes costs associated with costs for the bank overdraft lending operations and the amount of interest on the loan in the form of overdraft financing.

Formula (10) calculates the sum of the cost of the enterprise by using imported revolving lease for the entire period of the contract. This amount includes the costs associated with property and financial insurance, and insurance for the period of delivery of equipment, lease payments and payment of export customs duties and export customs fees in the form of leasing financing.

Formula (11) allows to calculate the amount of insurance coverage for property risk for the entire period of the lease agreement with the use of imported revolving lease. This amount consists of the sum of the cost of all insurance payments for property risk in the t-th year of operation for the entire period of the contract in the form of leasing financing.

Formula (12) allows to calculate the amount of insurance coverage for property risk for t-th year of operation using imported revolving lease. This amount consists of the sum of costs interest property insurance risk in the form of leasing financing.

Formula (13) allows to calculate the amount of the lease payment for the entire period of the lease agreement with the use of imported revolving lease. This amount consists of the sum of the cost of all lease payments in the t-th year of operation for the entire period of the contract in the form of leasing financing.

Formula (14) calculates the amount of the lease payment in the t-th year of operation using imported revolving lease. This amount consists of the sum of costs interest on the loan using revolving leasing, commission lessor, additional facilities costs, taking into account the depreciation rate of acceleration and payment of VAT in the form of financing leasing.

Formula (15) allows to calculate the amount of insurance coverage on the financial risk for the

entire period of the lease agreement with the use of imported revolving lease. This amount consists of the sum of costs interest insurance financial risk in the form of leasing financing.

Formula (16) allows to calculate the amount of insurance coverage for the period of delivery of equipment using imported revolving lease. This amount consists of the sum of costs interest insurance for the period of delivery of equipment leasing in the form of financing.

Formula (17) allows to calculate the amount of export customs duties of equipment using revolving lease, which includes customs duties on equipment leasing in the form of financing.

Formula (18) allows to calculate the amount of customs duties on exports of equipment. This amount includes the cost customs fees in foreign currency and rubles in the form of leasing financing.

Formula (19) – is a more detailed embodiment of formula (10), comprising the Formulas (11)-(18).

Formula (20) calculates the sum of costs of using imported revolving lease for 1 month in the t-th equipment operation period. This amount includes the cost for 1 month in the t-th period of exploitation related to property and financial insurance, and insurance for the period of delivery of equipment, lease payments and payment of export customs duties and export customs fees in the form of leasing financing.

Formula (21) calculates the sum of the costs associated with entering into a contract with a marketing company, consisting of payment wages to workers based on insurance premiums to non-budgetary funds and lawyer fee for the conclusion of the contract.

Formula (22) calculates the sum of costs of using a revolving credit facility, which comprises the sum of %-st on the loan revolving when lending.

Formula (23) allows to calculate the amount of enterprise costs associated with shipping on the territory of the Russian Federation, consisting of payment wages to workers based on insurance premiums to non-budgetary funds and payment of packaging.

Formula (24) calculates the sum of enterprise costs associated with shipping products on the territory of the Russian Federation, consisting of payment wages to workers based on insurance premiums to non-budgetary funds and cargo insurance.

Formula (25) calculates the sum of the costs associated with the shipment of products for export contracts, consisting of payment wages to

workers based on insurance premiums to extra budgetary funds, pay transportation costs and cargo insurance.

Formula (26) calculates the sum of costs of using factoring advance payment without recourse, comprising of costs associated with payment of fees for the examination of documents exporter, transportation costs, including the commission for making the bill of lading and the amount interest on the loan and fee remuneration in the form of financing forfaiting.

Formula (27) calculates the sum of costs using the sales franchising territorial franchise, which includes costs associated with the payment wages to hired consultant to develop a franchise package including insurance contributions to extra-budgetary funds, the cost of advertising and promotion of the franchise and the cost of training and support for franchisees.

Formula (28) calculates the sum of costs of using customs loan. This amount includes the cost amount of interest on the loan and the payment of maintenance fees, registration and storage of goods in customs warehouse, payment of export customs duties and customs fees.

Formula (29) calculates the sum of costs using the international forfaiting. This amount includes the cost of the costs associated with the sale of promissory notes for exported goods and transportation costs, including the commission for registration of a bill of lading forfaiting form of financing.

Formula (30) calculates the sum of the costs when selling promissory notes for exported products, consisting of nominal value of promissory note less the discounted rates bills in the form of financing forfaiting.

Formula (31) allows to calculate the promissory notes discounted price for exported products. This

amount includes the cost of a discount for exported products in the form of financing forfaiting.

Formula (32) allows to calculate the discount on the bill for exported products. This amount includes the cost amount of interest on the promissory notes in the form of financing forfaiting.

Conclusion

This innovative method of calculating the cost of the operating activities of the enterprise is able to maximize the full and detailed calculation of the cost of using the operating lease, technical overdraft, customs and revolving credit, factoring advance payment without recourse international forfaiting, sales franchise with territorial franchise, installment credit with payment and subsequent financing, leasing and imported revolving investment tax credit to finance innovation enterprise. This innovative set of tools makes it possible to attract additional financial resources for the operations of innovation-oriented enterprise. It also allows to increase the innovative potential of the company, providing its economic development and stability.

This innovative method of calculating the cost of the operating activities of the enterprise is able to maximize the full and detailed calculation of the cost of using the operating lease, technical overdraft, customs and revolving credit, factoring advance payment without recourse international forfaiting, sales franchise with territorial franchise, installment credit with payment and subsequent financing, leasing and imported revolving investment tax credit to finance innovation enterprise.

This innovative set of tools makes it possible to attract additional financial resources for the operations of innovation-oriented enterprise. It also allows to increase the innovative potential of the company, providing its economic development and stability.

References

1. Bjorn Andersen (2003). Business Processes. Improvement tools, Scientific. Ed. YP Adler. RIA "Standards and quality", pp. 178-185.
2. Elia M. Goldratt, Jeff Cox (2009). *Purpose: The process of continuous improvement*, Russia, Moscow: "Publisher potpourri", p. 215.
3. Gluschenko I.I. (2006). Evaluating the effectiveness of the system of innovative projects, *Menezhdment in Russia and abroad*, 3, pp. 43-47.
4. Guoting, S.V., Kalosha, V.P. (2007). Logical Framework Approach and its application for analysis and planning activities. Russia, Moscow: "Variant", p. 118.
5. Harrington James, Esseling Eric, Nimvegen Harm Van (2002). *Optimization of business processes. Documentation, analysis, management, optimization*, Russia, SPb.: ABC BMikro, pp. 310-320.
6. Kokurin, D.I., Agabeyov, S.I., Nazin, K.N. (2011). Innovations in Russia. System-institutional analysis, Russia, Moscow, Transliteration, pp. 376-384.
7. Kotler Philip, Berger Roland, BikhoffNils (2012). *Strategic Management by Kotler: The best techniques and methods*, Moscow, Alpina Publisher, pp. 58-65.
8. Nechayev, A.S. (2010). Improving the system of financial support for investment and innovation activity: dis. Doc. econ. Sciences. Russia, Moscow.

9. Nechaev, A.S. (2012). The algorithm of a comparative estimation of the basic form of financing. *Problems and trends of economy and management in the modern world Proceedings of the International Conference -Bulgaria, Sofia*, pp. 418-424.
10. Nechaev, A.S., Starkov, F.S. (2013). Some aspects of the production process of investing in the current economic conditions, *Vestnik of the Irkutsk State Technical University, Russia, Irkutsk*, 11 (82), pp. 365-371.
11. Ogniov, D.V., Nechaev, A.S., Dubinin A.R. (2006). The strategy of attracting investment in Russian industry, Russia, *Bulletin of the Siberian State Aerospace University Academician M.F.Reshetnev*, 5, pp. 184-187.