

Fluctuations of the Solitary Bubble at the Separation from the Air Cavity, Compressed by the Magnetic Field in Magnetic Liquid

M.L. Boev¹, V.M. Polunin^{1,*}, O.V. Lobova¹, I.A. Shabanova¹, L.M. Chervjakov¹, A.N. Ryapolov²

¹ Southwest State University, 94, 50 Let Oktyabrya Str., 305040 Kursk, Russia

² Gubkin Institute (the branch of the Institute) of FSFEI HVE, Moscow State Open University
named after V. S. Chernomyrdin, 16, Komsomolskaya Str., 309184 Gubkin, Belgorod Region, Russia

(Received 05 November 2013; published online 10 December 2013)

In the article, on the basis of the concept of "display" of geometry of a free surface of the "low-magnetic" environment by the topography of isolines of the module of intensity of a magnetic field, it is studied a form of a free surface of magnetic fluid in a static condition at the initial stage of rapprochement of a ring magnet with a surface of a column of magnetic fluid in a tube and at a stage of pressing of a cavity to a bottom. It is shown that the separation of bubbles from an air cavity occurs in close proximity to the plane of symmetry of a ring magnet on its axis. It is described the method and experimental installation for studying the possibility of electromagnetic indication of sizes of the air bubbles, being in magnetic fluid. It is discussed the results of experimental research on process of a separation of solitary air bubble from a cavity, contained in magnetic fluid and squeezed by ponderomotive forces of a magnetic field which are of interest for creation of essentially new technique of the dosed supply of small amount of gas in the reactor.

Keywords: Magnetic fluid, Geometry of a free surface of magnetic fluid, Magnetic levitation, Air cavity, Electromagnetic indication of sizes of air bubbles.

PACS numbers: 43.66. + y, 47.65.Cb

1. INTRODUCTION

Capture and relocation of a portion of air from a surface of a column of the magnetic fluid (MF), lying within a glass tube, are carried out by an operated flow of MF under the influence of ponderomotive forces of the non-uniform magnetic field moving in the axial direction. This process is specified in [1, 2]. Notice that the notification about stabilization of the bottom surface of a column of MF in a tube by means of a non-uniform magnetic field is provided in work [3]. Nevertheless, in this work there is no description of mechanisms of formation and movement of an air cavity. It's not investigated the following: the form of a surface of an air cavity, the process of a relocation of a cavity, steadiness of its volume in the conditions of pressing.

In process of movement of a ring magnet downward, the air cavity is forced by ponderomotive forces of a non-uniform magnetic field against a tube bottom. At reaching a critical value of pressure, there is a separation of an air bubble from a cavity. Turned out to be beyond limits of "a magnetic barrier", the air bubble makes elastic fluctuations in the magnetic colloid, accompanied by electromagnetic and acoustic radiation. In chemical and technological production and pharmaceuticals, when supplying into the reactor of small amount of gas, the effect of the acoustic-electromagnetic radiation, created by the pulsing bubble, can be of practical interest for providing a high-quality monitoring of process.

For comprehension of mechanisms of capture of an air cavity by an operated flow of MF, the separation of bubbles from an air cavity in the conditions of pressing, it is necessary to assume a form of a surface of a cavity, which in statics is defined by effect of a number of forces: ponderomotive forces (including magnetic pressure drop), force of a superficial tension of MF, force of gravity.

For this purpose it is made an attempt to study a form of a free surface in a static condition at the initial phase of rapprochement of a magnet with a surface of a column of MF in a tube and at a stage of pressing of a cavity to a tube bottom on the basis of theoretical model of the "low-magnetic" environment. The usable model assumes that MF represents as the "low-magnetic" environment in respect of which it is possible to neglect the degaussing fields, and magnetic volume force is much greater than the others (gravitational, capillary, magnetic pressure drop).

The solution of a task is consolidated to finding of surfaces of constant potential of magnetostatic force. Magnetic forces are prevailing over all the others, and the form of a surface of an air cavity within the tube will be defined by a condition of constancy of pressure on it, that is the constancy of potential of magnetic force. In its turn, for the fulfillment of this condition in relation to magnetized up to saturation MF, it is required the constancy of the module of a vector of intensity of a magnetic field ($H = \text{const}$). The conception of "display" of geometry of a free surface of magnetized up to saturation MF by topography of isolines of the module of intensity of a magnetic field is offered in work [4].

Thus, in considered approach, on a form of a surface of the air cavity, withheld by forces of magnetic levitation, essentially influence the peculiarities of topography of a magnetic field of a usable magnet.

2. TOPOGRAPHY OF THE MAGNETIC FIELD WITHIN THE TUBE

In order to define a form of surface of environmental separation, it is necessary to construct isosurfaces of the module of intensity of a magnetic field. As well as in works [5, 6] let's assume that the components of

* Polunin-vm1@yandex.ru

an induction of a magnetic field are calculated by the formula $\vec{B} = -\text{grad} \psi$, where scalar potential appear as follows:

$$\psi = -\frac{M}{2\pi} \left(\int_{R_1}^{R_2} K(k_1) \frac{k_1 q}{\sqrt{qr}} dq \right) - \frac{M}{2\pi} \left(\int_{R_1}^{R_2} K(k_2) \frac{k_2 q}{\sqrt{qr}} dq \right),$$

where $k_1 = 2\sqrt{qr}/((q+r)^2 + (z-h)^2)$;

$k_2 = 2\sqrt{qr}/((q+r)^2 + (z+h)^2)$; R_1, R_2 – internal and external radiuses of a magnet; h – its semi-thickness; $K(k)$ – elliptic integral of first genus.

The theoretical analysis of a magnetic field is carried out with the assumption that the ring magnet is magnetized with a constant by volume magnetization M , directed along its axis. Magnetization value M is

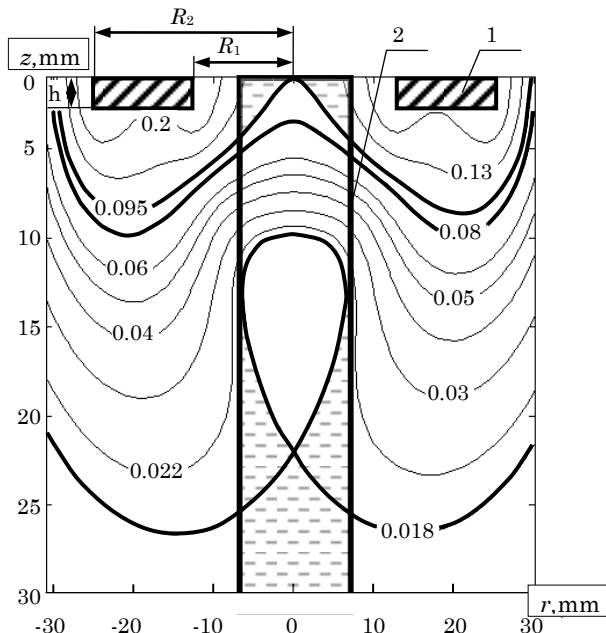

Fig. 1 – Isolines of a force field of a ring magnet

defined on measured in the center of a magnet value of induction of a magnetic field $B = 115$ mT.

Whereas the free surface of MF within limits of the usable model, depending on a relative position of a magnet to a considered area of a surface of fluid, occupies a position of some isosurface of the module of intensity of a magnetic field, we get a grid of isolines H within a usable tube.

Calculation of a field of force of a ring magnet is carried out in the environment of MATLAB.

The following parameters for calculation are set:

R_2 – the external radius of a magnet,

R_1 – the internal radius of a magnet,

h – a half-height of a magnet,

z – range of variation of of vertical coordinate z , which is vertical to plane of a magnet ($z = 0$ – the plane of symmetry of a magnet),

r – range of variation of horizontal (radial) coordinate ($r = 0$ – a magnet axis),

v – values of isolines of the module of intensity of a magnetic field.

Values of isolines are dimensionless, $v = 2\pi H/M$. H – the module of intensity of a magnetic field.

In our case it is used the magnet with sizes: $R_1 = 12,5$ mm; $R_2 = 25$ mm; $h = 2,5$ mm.

The result of calculation is illustrated in Fig. 1. Where 1 – the ring magnet magnetized along an axis, 2 – a glass tube with a diameter equal to 13,5 mm, the force field of a magnet is shown by isolines H .

3. FORM OF THE SURFACE OF THE CAVITY

In the bottom part of a tube in Fig. 1 it is shown the isoline 0,018. According to the conception of "display" of geometry of a free surface, the isoline 0,018 illustrates a form of a surface of MF at its current along tube walls at the initial stage of capture of an air cavity. The received "display" of a form of a surface of a near-wall layer of overflowing liquid, in Fig. 2 marked by shading, corresponds with data of visual observation [1, 2]. While the process of a magnet movement downward and its oncoming to a free surface of MF it is observed the evolution of a form of surface. At the beginning the free surface has a flat horizontal form. With the magnet oncoming to MF, its surface at first takes the concave shape close to a shape of an elliptic paraboloid, and then, ponderomotive forces, pressing a liquid to the tube wall, simultaneously adsorb it in the area of maximum field. On a tube surface in the plane of symmetry of a magnet it is formed the ring of MF.

At further lowering of a magnet the ponderomotive forces considerably surpass the force of gravity due to what the magnetofluidal ring thickens, and then blocks tube section. Under a crosspiece it is formed the isolated air cavity, which blocks the section of a tube. Further the thickness of a crosspiece grows by means of a liquid overflowing on an internal wall of a tube upward, and the air cavity forces its way downward.

It is important to note that at a magnet stop the overflow of a liquid stops. Thereafter, the internal surface of a tube between the top and bottom columns of MF is completely out of liquid. Thus, in an equilibrium condition the top and bottom columns of MF are divided by an air cavity.

Further lowering of a magnet leads to contact of an air cavity with a bottom of a tube and the subsequent press on it by a non-uniform magnetic field. At the achievement of threshold value of gas pressure in a cavity, there is a separation of a gas vial from it and the accelerated lifting under the influence of a resultant of three forces: the ponderomotive force of the non-uniform magnetic field, the buoyancy force (Archimedean) force and power of viscous friction:

$$\mu_0 \cdot M \cdot \nabla H \cdot V + F_A - F_s,$$

where V – the volume of the air bubble, M – magnetization of magnetic fluid, H – intensity of a magnetic field, μ_0 – a magnetic constant, F_A – the buoyancy force, F_s – resistance force.

Obviously, the bubble separation from a cavity occurs on an area of its surface, which is most closely located to the plane of symmetry of a ring magnet, coinciding with the top side of a rectangular restrictive frame in figure 1. In order to make a more concrete conclusion on location of an area of inception of a bubble, return back to topography of a magnetic field (Fig. 1).

With the plane of symmetry of a ring magnet contacts the isoline of intensity of a magnetic field with value 0.095. The surface of the cavity, located under a magnet, has a similarity to the cone surface, the top of which rests against the plane of symmetry of a ring magnet. The bottom part of MF column, being over a cavity surface in Fig. 2 is marked by shading.

The obtained data are adequately correspond with the results of determination of form of a free surface of MF, based on usage of a matrix form of representation of parameters of a magnetic field [1, 2]. So, according to the provided in specified works data, at placement of a free surface of MF along the isoline with value 0.095, a column height of MF under the plane of symmetry m and apex angle of cone α are accordingly equal to 2.5 mm and 55° . At placement of a free surface of MF along the isoline with value 0.08, the values m and α are equal to 4.5 mm and 23° . Thus, a cone-apex angle depends on the set height of MF column. With the increase of m , the value α decreases that is straightforwardly confirmed by direct observations.

It follows from what has just been said above, that the separation of bubbles from the air cavity occurs at the cone top at a point being on an axis of a ring magnet (on a tube axis) in the plane of symmetry of a ring magnet. While the magnet oncoming to a bottom of a tube, the forces of magnetic levitation at first bring a cavity into contact with a bottom, and then create an excessive pressure in it. At achievement of critical pressure drop, there is a formation and separation of an air bubble from a cavity, being accompanied with acoustic and electromagnetic radiation.

4. SIZES OF BUBBLES

Researches are performed on the sample of MF, representing nanodispersed particle system of magnetite F_3O_4 in kerosene. As the stabilizer of system it is used oleic acid. Density ρ , initial magnetic permeability χ , magnetization of saturation M_s and a coefficient of superficial tension σ of an investigated sample are received on the basis of known techniques [6, 7]. Numerical values of the specified parameters are: $\rho = 1320 \text{ kg/m}^3$, $\chi = 3,76$, $M_s = 44,3 \text{ kA/m}$, $\sigma = 0,028 \text{ N/m}$.

It is carried out a "preliminary" assessment of radius of the bubble, separated from an air cavity, upon value of its "average volume" V_0 which is obtained by division of initial volume of the entrapped air cavity into the number of electromagnetic impulses – indicators of a separation of bubbles. Meanwhile we get: $R_0 = \sqrt[3]{3V_0/4\pi} \approx 1 \text{ mm}$.

Turned out to be higher than the plane of symmetry of a magnet ("a magnetic barrier"), the air bubble makes the elastic radial fluctuations accompanied by electromagnetic radiation [8].

For studying electromagnetic radiation spectrum which is radiated by a bubble, it is developed the experimental installation which is schematically presented in Fig. 2.

The glass tube with a bottom 1, filled with MF 2, is rigidly fixed on a metal structure 3 by means of a fixing flange 4. Over an air cavity 5 coaxially to a tube it is located the ring neodymium magnet, magnetized along an axis 6. The magnet is fixed on kinematic knot of the cathetometer 7. In a magnet is built in the coil of inductance 8. The signal from the inductance coil after strengthening by the selective amplifier 9 arrives in parallel on the oscillograph 10 and the analog-digital converter 11, connected with the computer 12. When obtaining oscillograms it is applied the program developed in the environment of NI LabVIEW.

The oscillograms of electromagnetic signals, shown in Fig. 3a, 3b and 3c in relative units, provide certain information on movements of particles of magnetic liquid at the formation of bubble and its fluctuations.

Peculiarities of the oscillogram of Fig. 3a allow to assume that in a time period 1-5 with a duration of 7 ms, there are MF microstreams in a vicinity of extended in the vertical direction area of a surface of a cavity. This is proved by presence on the oscillogram of negative and positive peaks of the accepted signal relating to high amplitude with duration of $\sim 3,5 \text{ ms}$ each. Microstreams of MF occur at insignificant penetration of a cavity beyond "a magnetic barrier", formation and a bubble separation, setting of an equilibrium (final) shape of a cavity.

The segment of the oscillogram 2-4 with the duration $\sim 2,6 \text{ ms}$ contains a radioimpulse, radiated by the fluctuating bubble (in Fig. 3a it is designated by numeral 3). As the push, disturbing the oscillatory system from an equilibrium condition – "the air bubble in fluid", can serve the water hammer, which occurs at closure of a throat of a bubble coming off a cavity.

From the time $\sim 0,025$ develops a process of fading fluctuations in oscillatory system, in which an inertial element is MF column in a tube, and an elastic element – is the air cavity suppressed by forces of a magnetic levitation. This process is presented by the oscillogram in Fig. 3b. As the push to excitation of oscillations of this given oscillatory system, probably, serves the hydroblow caused by the completion phase of the microstream at the formation of an equilibrium shape of a surface of cavity. According to the oscillogram we find the values of frequency of fluctuations and of coefficient of attenuation of system: 30 Hz and 16 c^{-1} . The represented data are adequately correspond with the results of measurements of parameters of the similar oscillatory system, presented in works [1, 2].

In Fig. 3c in the integrated time scale it is presented the oscillogram of the radio impulse, radiated by the fluctuating bubble. By the standard method on duration of five full waves, we receive the period and frequency of fluctuations of an air bubble ν . In our case $\nu = 2500 \text{ Hz}$.

In its turn the frequency of fluctuations of a bubble in nonviscous liquid is connected with its radius by known equation [9]:

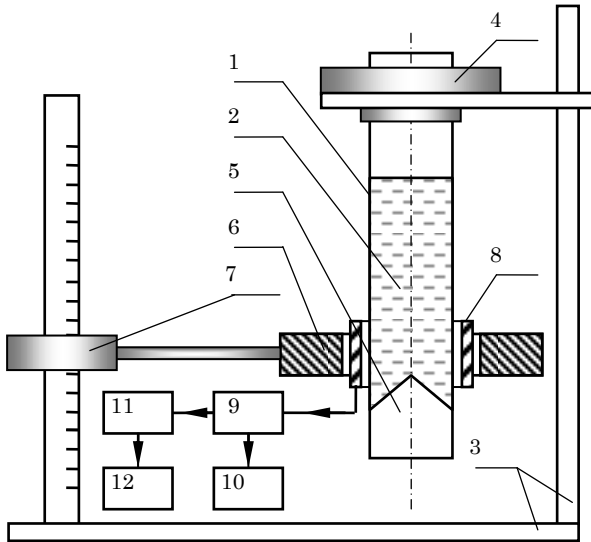

Fig. 2 – Block-diagram of experimental installation

$$v = \frac{1}{2\pi R_0} \sqrt{\frac{3\gamma(P_0 + 2\sigma/R_0)}{\rho}},$$

where R_0 – radius of a bubble, P_0 – hydrostatic pressure, $\gamma = C_p/C_v$ – the relation of specific thermal capacities of gas in a bubble, σ – coefficient of a superficial tension of MF, ρ – density of MF.

The value $2\sigma/R_0$ considering the action of forces of a superficial tension, at $\sigma = 0,028$ N/m and $R_0 \approx 1$ mm is ≈ 56 Pa. As far as in conditions of experiment $P_0 = 10^5$ Pa, then it is possible to neglect the second member in brackets under the radical and to lead this formula to a form:

$$v = \frac{1}{2\pi R_0} \sqrt{\frac{3\gamma P_0}{\rho}}.$$

Accordingly for origination of R_0 we get:

$$R_0 = \frac{1}{2\pi v} \sqrt{\frac{3\gamma P_0}{\rho}}$$

Accepting $\rho = 1320$ kg/m³, $\gamma = 1,4$, and the value received from experiment $v = 2,5$ kHz, we get: $R_0 = 1,14$ mm. The given result confirms and specifies the above mentioned assessment of value R_0 .

At a bubble separation, some portion of air mass Δm leaves a cavity. The assessment of numerical value Δm can be received by formula:

$$\Delta m = \rho_g \frac{4}{3} \pi R_0^3,$$

where ρ_g – gas density (in the instant case - air).

Accepting $\rho_g = 1,29$ kg/m³ and the above mentioned value R_0 , we get $\Delta m = 8 \cdot 10^{-9}$ kg = $8 \cdot 10^{-3}$ mg. The value Δm appears to be even slightly less, than the mass of a portion of the gas, leaked by a magnetofluidal membrane [7]. Besides, the considered method of electromagnetic indication of the sizes of the gas bubbles surrounded with nanodispersed magnetic fluid, allows to

determine with high precision the size and mass of gas portion, which is enclosed in each separate bubble, while the "membrane" method gives an averaged value of a large number of portions of gas and needs a preliminary graduation. This fact matters at a device choice for high-quality monitoring of process of the dosed supply of gas in the reactor [10].

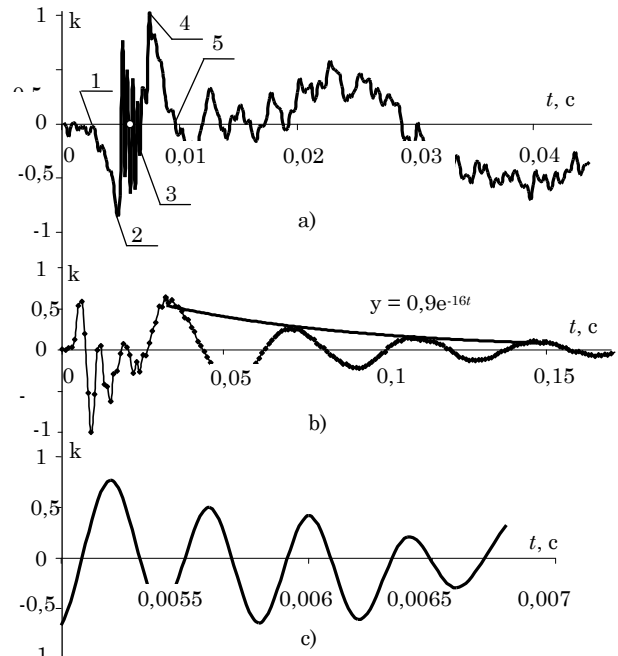

Fig. 3 – Oscillograms of fluctuations

5. CONCLUSIONS

1. Within the limits of model of the "low-magnetic" environment, the conception of "display" of geometry of a free surface of magnetic fluid by the topography of isolines of the module of intensity of a magnetic field, allows to study a shape of a free surface in a static condition at the initial phase of rapprochement of a ring magnet with a surface of MF column in a tube and at a stage of pressing of a cavity to a bottom. Depending on a location of a magnet towards the free surface of fluid, it is built one or another configuration of a surface.

2. As the magnet gets close to a free surface of MF, a surface curvature occurs. At first the surface takes the concave shape close to a shape of an elliptic paraboloid, that coordinates with data of visual observation.

3. The shape of an area of a cavity surface pressed to a bottom of a tube by ponderomotive forces of a non-uniform magnetic field, locating on an axis of the ring magnet in the plane of symmetry, is close to the conic. In vertex of a cone occurs a separation of bubbles from an air cavity.

4. The method and experimental installation are worked out for studying the possibility of electromagnetic indication of sizes of the air bubbles, being in nanodispersed MF. The oscillograms, providing the information on movements of particles of magnetic fluid at formation of a bubble and its fluctuations, are received and analysed.

5. The method of electromagnetic indication of sizes of gas bubbles in MF allows to determine with high pre-

cision the size and mass of gas portion, which is enclosed in each separate bubble. This fact matters when choosing a device for high-quality monitoring of process of the dosed supply of small portions of gas in the reactor.

AMS is grateful for funding of this work via the Grant of the President of the Russian Federation for support of young researchers No. MK-498.2013.2.

REFERENCES

1. V.M. Polunin, M.L. Boev, M.M. Than, P.A. Ryapolov, *Magneto hydrodynamics* **48** No3, 557 (2012).
2. V.M. Polunin, M.L. Boev, M.M. Than, G.V. Karpova, L.I. Roslyakova, *Acoust. Phys.* **59** No1, 63 (2013).
3. R.E. Rosensweig, *Ferrohydrodynamics, Cambridge Monographs on Mechanics and Applied Mathematics* (New-York: 1985).
4. V.G. Bashtovoy, B.M. Berkovsky, A.N. Vislovich, *Introduction to Thermomechanics of Magnetic Fluids* (M: IVTAN: 1985).
5. V.M. Polunin, I.A. Schabanova, M.L. Boev, et al., *Magneto hydrodynamics* **47** No 3, 303 (2011).
6. V.M. Polunin, I.A. Shabanova, O.V. Lobova, E.B. Postnikov, *Acoust. Phys.* **58** No3, 281 (2012).
7. V.M. Polunin, *Acoustic Properties of Nanodispersed Magnetic Fluids* (M: PhysMathLit: 2012).
8. P.S. Landa, O.V. Rudenko, *Acoust. Phys.* **35** No5, 855 (1989).
9. M.G. Sirotyuk, *Acoustic Cavitation* (Ex. Ed. V.A. Akulichev, L.R. Gavrilov) (M.: Science: 2008).
10. S.G. Yemelyanov, N.S. Kobelev, V.M. Polunin, et al., Patent RF №2273002. Gas regulator. – № 2008106301/28; decl. 18.02.2008; publ. 10.09.2009. Bull. № 25.