

ЧЕРТЕНКО Л.П.

Київський національний університет технологій та дизайну

РОЗРОБКА ФОРМУВАЛЬНОЇ КОЛОДКИ ДЛЯ ВИГОТОВЛЕННЯ ВЗУТТЯ ДЛЯ КІННОГО СПОРТУ

Наукова новизна. Запропонована в роботі конструкція формувальної колодки для взуття для кінного спорту, розроблена на основі антропометричних параметрів стопи та гомілки, проектується з використанням комбінації зворотного і прямого моделювання форми, що дозволяє досягти ідеальної оригінальної тривимірної форми, що поєднує ергономічність і красивий дизайн. Такий спосіб проектування дозволяє використовувати доступне цифрове обладнання для отримання вихідних даних.

Виробництво такого виробу як взуття для кінного спорту (жокейські чоботи) вимагає додаткового оснащення у вигляді спеціальної формувальної колодки для формування халяви чобіт, та надання їй особливої просторової форми.

Формувальна колодка для чобіт представляє собою стилізовану форму ноги від стопи до коліна. Нижня частина, що відповідає колодці, проектується на основі параметрів середньої стопи з урахуванням вимог біомеханіки, фізіології і естетичних особливостей стилю взуття. Верхня частина повторює параметри гомілки і має специфічну асиметричну форму, яка забезпечує стильну і досконалу форму взуття для кінного спорту. Для отримання вихідних даних для проектування форми були проведені антропометричні обміри гомілок молодих жінок, розмір стопи яких відповідає середньому по обраній вибірковій сукупності.

Проектування нижньої частини форми здійснювалося на основі усереднених параметрів стопи в програмному комплексі Crispin LastMaker на основі методу зворотного інжинірингу. Проектування загальної форми відбувалося в середовищі PowerShape за допомогою функцій поверхневого, твердотільного і гібридного моделювання.

Такий різновид чобіт повинен бути виготовлений в декількох повнотах, а також має бути забезпечена можливість виготовлення чобіт різного дизайну. Тому з метою ефективного застосування формувальної колодки (boot-tree) в роботі була запропонована форма-трансформер, котора дозволяє виготовляти чоботи різної ширини та з різною формою носкової частини завдяки конструкції з чотирьох частин, змінюючи взаємне розташування та окремі елементи яких можна досягти універсальності використання.

Затяжна колодка виготовлялася шляхом фрезерування на професійному обладнанні (5-координатний станок) з ЧПУ із спеціальних поліпропіленових болванок (заготовок). Всі чотири фрагменти формувальної колодки виготовлялися в правому-лівому варіанті з деревини на 4-х-координатному ЧПУ-станку з поворотною віссю. Виготовлені на затяжних колодках та відформовані за допомогою формувальної колодки чоботи отримали схвальні відгуки про комфортні та естетичні властивості форми.

Актуальність роботи обумовлена необхідністю оснащення взуттєвого виробництва вдосконаленими колодками і формувальними пристосуваннями з урахуванням вимог ергономіки і модного дизайну

Мета роботи. Розробка вдосконаленої форми, конструкції і способу проектування формувальної колодки для чобіт на основі 3d скану стопи та параметрів гомілки за допомогою функцій сучасних САПР

Ключові слова: формувальна колодка для чобіт, взуття для кінного спорту, взуттєва колодка, поверхневе моделювання, 3D дизайн, ЧПУ фрезерування.

DEVELOPMENT OF A BOOT-TREE MOLD FOR MANUFACTURING RIDING BOOTS

LILIYA CHERTENKO

Kyiv National University of Technologies and Design

The production of such footwear as riding boots requires additional equipment like a special mold for the formation of bootlegs, which are made using intermediate frame parts to ensure rigidity and preserving shape.

The special mold of riding boots is a stylized shape of the leg from its foot to knee. The lower part corresponding to the shoe last is designed based on the parameters of the average foot, taking into account the requirements of biomechanics, physiology, and aesthetic features of the shoe style. The upper part repeats the parameters of the shin and has a specific asymmetrical shape, which ensures a stylish and perfect form of the riding boot. To obtain the initial data for designing the mold, there were performed anthropometric measurements of the shins of young women whose feet sizes correspond to the average ones in the selected sample.

Designing of the lower part of the mold was carried out on the basis of the average parameters of the foot in Crispin LastMaker software complex using the method of reverse engineering. Designing of the general shape was performed in the PowerShape software environment by means of the features of surface, solid, and hybrid modeling.

This type of boots must be made with several width-girth parameters, and the possibility to make boots with different designs must be provided. Therefore, in order to effectively use the molding means (a boot-tree), in the work, there was proposed the transforming mold, which allows making boots of different widths and with different shapes of the toe part due to its structure consisting of four parts changing the relative position and individual elements due to which it is possible to achieve multipurpose usage.

Objective. *Development of an improved shape, design, and method of designing a boot-tree molding means based on the foot 3d scan and shin measurements using the features of modern CAD software.*

Topicality *of the work is based on the need to equip footwear production with the advanced lasts and molding means taking into account the requirements of ergonomics and fashionable design.*

Novelty. *The proposed structure of the boot-tree developed on the basis of foot measurements is designed using a combination of reverse and direct modeling of the shape, which allows achieving the ideal and unique 3D shape combining ergonomic features and beautiful design. Such design method allows using the available digital equipment to obtain the initial data.*

Keywords: *boot-tree, riding boots, shoe last, surface modeling, 3D design, CNC milling.*

The current stage of development of the footwear industry is characterized by the use of high production technologies and huge competition of goods on the market. In such conditions, a particularly important factor of success is the compliance of products with the requirements of ergonomics along with aesthetically pleasing look. When searching for the promising areas of production, it is necessary to take into account the fact that the sustainability trend in the fashion industry is gaining popularity. This trend makes modern fashion more versatile and practical.

Many types of shoes fit into this trend and create good competition for fashion shoes that become outdated after one season. Sustainable fashion is more durable, it is designed for a long wear period, therefore, it requires a scientifically-grounded approach to developing the mold and construction.

One of such promising and always relevant

trends is riding boots, which are firmly established in women's fashion.

However, this type of footwear requires additional equipment such as a special mold for the formation of bootlegs, which is made using intermediate frame parts to ensure rigidity and preserving shape.

The special design of the shin mold should be multifunctional since it must be applicable for molding boots of different sizes and widths. Therefore, the work will focus on the transforming mold, which consists of separate interconnected parts that can be replaced.

The basis for creating the mold of the bootleg is the average parameters of a female shin. However, fashion trends and design features of boots must also be taken into account when modeling the mold. Leading Italian designers dictate the fashion for the shape of boots of this type of style.

Major factor of shoe comfort is the compliance

of the last with the parameters of the foot, taking into account the requirements of biomechanics and physiology. According to the statistics, more than 50% of consumers are not satisfied with the comfort of the shoes they buy. For everyday shoes that are being in use for a long time, this is unacceptable.

The comfort of footwear mostly depends on the ergonomic shape of a last. As for these requirements, the worst situation is in the area of elegant and fashion shoes. Apart from the fact that they are often not really comfortable, they can worsen the postural control, according to a study [1]. People wearing heels higher than 2 inches are more prone to developing footwear-related problems like forefoot pain, which was indicated in the study [2].

The current state of computer technology and specialized measuring equipment, as well as the high level of 3D digitization, along with the ease of obtaining accurate data, allows the widespread use of 3D technology to obtain information about the shape and medical condition of the feet of people.

3D scanning indicates the existence of many statistically significant differences in mean foot measurements across different regions and genders [3] and the use of 3D scanners as well as digital methods for achieving foot anthropometric data accuracy and personalization is higher compared to the traditional methods [4]. These technologies help to design a complex 3D mold of a last in a virtual 3D space and allow overcoming various problems faced in footwear personalization [5]. 3D scanning technology is also widely used in designing shoe lasts for mass production of footwear. For example, Brian proposed an algorithm for calculating and constructing a 3D statistical foot mold based on the averaging of scanned foot models of a certain group of people.

Despite the high level of development of the industry and the introduction of advanced technologies in enterprises, we still often wear uncomfortable shoes.

After analyzing correspondence of the available shoe range in the stores to consumers' feet and conducting surveys about the pain and overall perception of comfort, the researchers came to a disappointing conclusion that the number of unsatisfactory shoes which do not meet any of the comfort criteria comprises nearly 43% [6]. Studies about the footwear fitting for the people of the studied categories reveal that from 63% to 72% of participants were wearing shoes that did not correspond to width or length parameters of their feet, as described [7]. Studies [8-9] examined the feet of both women and men using a convenient sample consisting of individuals who regularly visited specialized

clinics. The works found that from 35% to 56% of people wore shoes of the wrong length. In addition, 64% of individuals wore shoes that were narrower than their feet.

One of the main signs of the quality of shoes is their comfort, which majorly depends on the proper design of the shoe last. Wrongly selected or improperly designed shoes serve as the main factor causing structural disorders of the foot such as hallux valgus and the deformity of toes, apart from the skin lesions such as ulcers.

Designing of shoe lasts with the use of foot measurements and taking into account the foot shape enables to improve the compliance and fitness of footwear [10].

Studies [11] described which foot measurements are most important for the fitness (correspondence) of shoes, and [12-13] used full 3D foot shapes to determine the degree of conformity of shoes to feet. Numerous researchers have used 3D scanners to study the quality of the adjoining of the foot to the shoe. Authors [10, 14] proposed a method of improving the level of conformity of shoes by comparing certain parameters of the foot scan with the parameters of the scanned lasts in certain areas.

The fitness and suitability of the shoes are closely linked to comfort and convenience. Subjective evaluations constitute the final step in shaping consumer-product interaction [15] and provide information about the perception of comfort and satisfaction. Shoe comfort assessment is an aspect that is widely studied using subjective measures such as questionnaires and surveys as well as objective measures such as pressing in different parts of the foot [16-17]. To measure subjective results, a comfort questionnaire is typically used, which has been specially designed and approved for running shoes with various insoles / orthoses in cross-trainers [18-19]. Objective measures can also include the analysis of the conformity of the physical parameters of the foot and the inner shape of shoes by comparing the three-dimensional shapes and two-dimensional sizes and cross-sections performed using 3D scanners and CAD software features.

Works [20, 6] are devoted to the development of a mathematical model for predicting the conformity of footwear taking into account objective and subjective criteria based on the development of a critical model of the foot (6) and conformity indicators of the feet with similar parameters (20).

Determining the numerical parameters of the lasts and feet for elegant shoes is closely linked to identifying the tolerances between the foot measurements and sizes of the last. The shoe last is not an exact copy of the foot, and determining the allowable ranges of deviations between the

parameters of the foot and the last is a complex and controversial task, but it is very important. In the works written by Au [21] and Witana [10], there were established the allowable and optimal values of the reduction of the transverse parameters of the foot when designing the last in the respective zones, which can be used in this work.

Methodology

The main way to obtain initial information for designing shoe lasts is to conduct massive anthropometric studies of the feet of the target segment of consumers.

The design of the shoe last in this work was based on the results of anthropometric measurements of the feet of young women in Ukraine, carried out using a specialized non-contact 3D scanner [22].

The upper part of the mold is designed based

on the average parameters of a shin.

It is also recommended to use 3D scanning for measuring the shin. However, research has shown that many portable scanners tend to set too high girth parameters of the object [23]. Taking into account the lack of the possibility of using a highly accurate scanner to obtain information about the 3D mold of the leg till the required height (450 mm), we used manual measurements for this zone. With the right approach to the measurement process, manual measurements provide a good result.

Therefore, anthropometric measurements of the shins of women of a homogeneous age group were performed using manual measurements with a flexible measuring tape. The shin girths were measured in the most important anthropometric regions along with the height to each measured perimeter.

Table 1

Results of Anthropometric Measurements of the Shin Parameters of Ukrainian Women from a Homogeneous Sample with a Foot Length of 247.5 ± 2.5 mm

Name of the parameter	Conventional sign	$\bar{M} \pm m$, mm	Standard deviation, σ , mm
Shin girth below the knee	Kgth	329.5±0.9	7.2
The height of the location of the shin perimeter below the knee	Kh	425.7±1.3	12.6
Shin girth at the widest point (calf muscle)	Wgth	355.2±0.6	5.6
The height of the perimeter of the shin in the widest point	Wh	319.8±1.4	13.2
Shin girth in the middle between the widest and narrowest areas	Mgth	293.3±1.1	9.6
The height of the shin girth in the middle between the widest and narrowest areas	Mh	208.6±1.0	8.8
Shin girth at the narrowest point (above the shin joint)	Ngth	224.1±0.5	4.9
The height of the shin girth in the narrowest point	Nh	107.8±0.5	4.4
Short heel girth of the foot	Gsh	309.8±0.8	6.7

The boot-tree mold is a stylized shape of the leg from a foot to a knee. The lower part, along with the shoe last, is designed based on the parameters of the midfoot, taking into account the requirements of biomechanics, physiology, and aesthetic characteristics of the shoe style.

The upper part repeats the parameters of the shin and has a specific asymmetrical shape that ensures a stylish and perfect shape for the riding boot.

The design of the lower part of the mold, which corresponds to the last, was carried out

in the Crispin LastMaker software package. The overall mold was designed in the PowerShape environment using surface, solid, and hybrid modeling features.

The process of modeling the mold of the last is performed using the method of reverse engineering based on the average parameters of women's feet obtained as a result of mass measurements of feet [22].

From the studied sample, there were selected normal feet which had no pathologies and deformities and their parameters corresponded to the mean parameters calculated for the sample. These feet were scanned on a 3D scanner, as a result of which, their photo-prints

were obtained, and, based on them, the averaged shape of the footprint was obtained. After that, we have chosen a foot, the shape of which most closely matches the averaged photo-footprint. Further, in LastMaker software, we edited the parameters of the selected foot, bringing them into full compliance with the averaged parameters of the studied group.

Further, we used the resulting average 3D model of the foot as a basis for designing the last (Fig. 1a). The basis of the complex 3D mold of the last is the contour of the lower surface, which corresponds to the shape of the main insole. This contour was designed according to the averaged footprint (Fig. 1b).

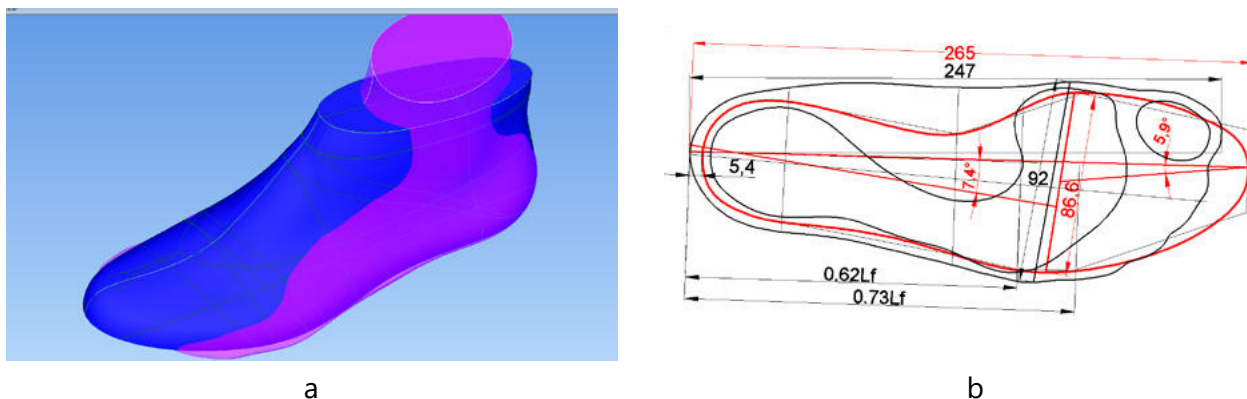

Figure 1. Designing the Contour of the Lower Surface based on the Averaged Footprint and Modeling the 3D Mold of the Last according to the Average 3D Model of a Foot

The general sequence of the boot-tree shape design process is shown in the diagram (Fig.2)

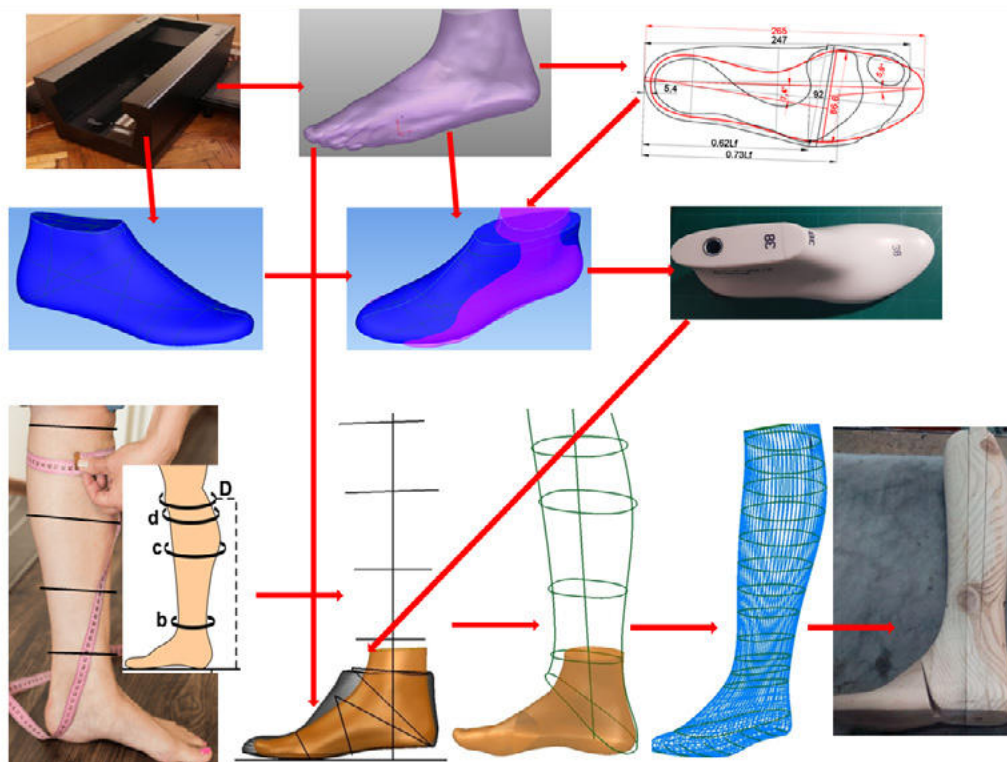

Figure 2 The main stages of the boot-tree design process

Research Results

Since the shape of this last and the shape being developed belong to elegant fashionable styles, when designing them, it is necessary to take into account the amount of permissible compression of the foot by the shoes and allowable reductions in the lateral parameters of the foot in different areas.

Guided by the results of research [22], as well as previous practical experience, as a part of experiment, we have developed a last with

two widths and different degrees of reduction in the lateral parameters of the foot (that is, molds with different tightness) (Table 2). Both last molds were manufactured on a last factory using specialized CNC machines.

Both of the manufactured shoe lasts were tested in terms of the comfort of the shoes manufactured using them. This testing experiment involved girls whose feet parameters corresponded to the average parameters of the studied group of consumers (see Table 2).

Table 2
The Parameters of the Lasts Designed as a Base for the Development of the Boot-tree Mold

Feet Parameters	Averaged Foot Measurements, $M \pm m$, mm	Limits of the Foot Parameters for the Average Size of the last, mm	Last 1 Parameters mm	Last 2 Parameters mm
1. L1– Length	247.1±1.1	245-250	262	262
6. Width of the ball (cont.) – Ball width based on the contour	91.8±0.6	90-94	88	86.6
7. W of the ball (impr.) – Ball width based on the footprint	84.9±0.5	82-87	84.5	83.2
9. W of the heel (cont.) – Heel width (contour)	69.3±0.4	67-71	64.9	63.7
10. Width of the heel (impr.) – Heel width based on the imprint	53.4±0.3	50-55	60.5	59.4
12. Balls’ Middle Girth	234.1±1.1	227-236	234.0	226.5
13 Instep Girth	235.5±1.0	230-240	245	237
14. Shot Heel Girth	327.7±1.4	315-336	344	332
18. Height of the Point of the Ankle Girth	73.4±0.8	68-79	77	75

The test results showed that the wide last was considered too loose by the majority of the respondents. The narrower last was determined to be comfortable and this mold became the base of the lower part of the boot-tree mold.

Next, the designed last was imported into PowerShape to construct the rest of the mold. The basis for modeling the upper part was the transverse shin girths obtained from measurements. Design sequence is as follows:

- 1) obtaining cross-horizontal sections of the last;
- 2) construction of the central vertical axis of a shin;
- 3) designing of the shin front line;
- 4) construction of horizontal sections of the

shin mold;

5) designing of the outer and inner vertical contour of the shin;

6) modeling of the shin mold based on the designed horizontal sections and sections of the upper part of the last using surface modeling features;

7) adjusting of the resulting mold, taking into account aesthetic requirements;

8) control check of girth parameters of the mold.

At the same time, an important factor that determines the silhouette lines of the mold of the bootleg is the style of boots. Riding boots are usually made in two styles involving a boot that fits the shin along the entire height and a

“pipe” boot with a straight loose silhouette. In this work, the mold of a tight-fitting elegant boot was developed.

The design of the mold begins with the construction of the vertical central axis of a shin, which is drawn through the middle of the heel part at the level of the internal condyle (Fig. 3a). Perpendicular to this axis, at the height of the shin measurements, we should draw horizontal planes, at the level of which we need to project

the ellipses of the horizontal sections of the shin. Next, we need to model the surface (Surface along Sections feature) from the top of the last to the top of the shin. Based on the modeling result, if necessary, we should add intermediate contours and adjust the sections so as to obtain a beautiful boot shape. In fact, at this stage, it is necessary to correct the shape of the cone part of the base last to ensure a smooth and integral shape of the boot (Fig. 3b).

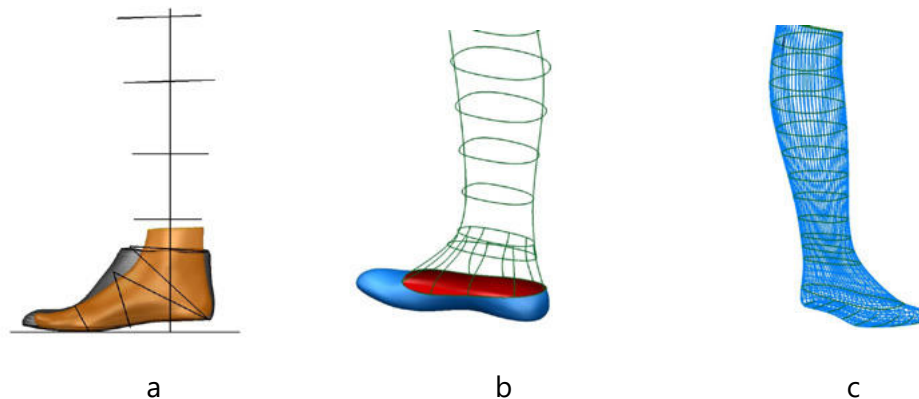

Figure 3. Constructing of a 3D Mold of a Boot-tree

According to the results of a survey about the problems of inconsistency and discomfort in finished shoes conducted on specialized forums and in social media, one of the main problems was the inability to choose shoes of the required width. This problem is especially acute for riding boots because of the use of rigid and form-stable intermediate pieces in manufacturing them. Boots made in this way are extremely difficult to mold when they are worn and their bootlegs do not stretch. Therefore, such boots must be made with several width parameters.

That is why, in order to effectively use the molding means (the boot-tree), a transformable design was proposed in the work, which allows producing boots of various widths due to the

construction of a shin from separate parts, between which there can be added additional inserts that change the girth parameters of the bootleg.

To create a universal transforming mold applicable for molding the bootlegs of shoes of different styles and different parameters of the shin, there was proposed a construction consisting of 4 parts (Fig. 4), which are connected in a special way, ensuring the convenient use, the ability to replace individual fragments, and easy adaptation to the desired parameters. Toe and ball part of the mold corresponding to the shape of the last can be made in several adjacent sizes and in different styles of the toe part, which increases the versatility of the mold.



Figure 4. Boot-tree Construction

Each of the four parts of the mold was made with the use of a four-way CNC machine (Fig. 5).



Figure 5. Production of Mold Segments on a CNC Machine

Boots manufactured and formed with the help of the mold showed that they fit a leg very well and had an aesthetically pleasing boot shape (Fig. 6).

Conclusions

The boot-tree mold is a complex 3D object that takes into account the average parameters of both feet and shins of the target group of consumers. To obtain the initial data for the design of the mold, relevant anthropometric studies were carried out. For modeling of the 3D boot-tree shape, the work proposes using 3D modeling features of multifunctional PowerShape CAD software along with applying both reverse engineering (for the shape of the last) and direct engineering (for the shape of the

shin). For convenient and effective use of the developed mold, a special transforming structure is proposed which consists of four separate elements that can be joined, disassembled, or partially replaced by others. Thus, we have achieved the versatility of the structure that can be used to mold boots of different widths, sizes, and with various toe part designs.

Shoe last was produced on professional CNC equipment from specialized polypropylene ingots (blanks) by milling. The boot-tree mold was made of wood on a four-way CNC machine with a rotary axis. Boots that are made on shoe lasts and formed with the help of a boot-tree mold received positive reviews about the comfort features and aesthetic properties of the shape.



Figure 6. Assembled Mold and a Boot Made with its Help

References

1. Emmanouil, A. A and Rousanoglou, E. N. (2018), "Effect of high-heeled shoes on postural control in the upright and the leaning body stance", *Phys Med Rehabil Res*, 3 (5), 1-5. doi: 10.15761/PMRR.1000184.
2. Khabia, V and Haral, P. (2017), "Community Awareness of Risks Related to Footwear Problems" *International Journal of Health Sciences and Research*, 2249-9571.
3. Jurca, A., Žabkar, J. & Džeroski, S., (2019), "Analysis of 1.2 million foot scans from North America, Europe and Asia", *Sci Rep*, 9. <https://doi.org/10.1038/s41598-019-55432-z>.
4. Baksa, S, Baksa, I and Mijović, B. (2019), "3D scanner application in the function of digital foot anthropometry", *Leather & Footwear*, 68, <https://doi.org/10.34187/ko.68.2.5>.
5. Germani, M., Bernabeu, J.A., Mandolini, M., Mengoni, M., Raffaelli, R. (2012) "A knowledge-based design process for diabetic shoe lasts", *Dubrovnik - Croatia : International Design Conference*, 889-900.
6. Nácher, B., Alemany, S., González, J., Alcántara, E. (2006), "A Footwear Fit Classification Model Based on Anthropometric Data", *SAE International*, doi: <https://doi.org/10.4271/2006-01-2356>.
7. Goonetilleke, R. S., (2012), *The Science of Footwear*. Taylor & Fransis Group.
8. Schwarzkopf R, Perretta DJ, Russell TA, Sheskier SC. Foot and shoe size mismatch in three different New York City populations. // *J Foot Ankle Surg*. 2011;50(4): P. 391–394.
9. Akhtar S, Choudry Q, Kumar R. Incorrectly fitting footwear and associated foot problems. *Orthopaedic Proceedings*. 2008;90(3): P. 495–496.
10. Witana CP, Feng J, Goonetilleke RS: Dimensional differences for evaluating the quality of footwear fit. // *Ergonomics* 2004, 47(12): P. 1301–1317. doi: 10.1080/00140130410001712645.
11. Rossi, W.A. and Tennant, R. *Professional Shoe Fitting, Pedorthic Footwear Association*, New York, 2000, 162 p.
12. Mochimaru M., Kouchi, M. Shoe customization based on 3D deformation of a digital human // *The Engineering of Sport*, vol. 4 p. 595-601, 2002.
13. Borchers R. E., Boone D. A., Aaron W. J., Smith D. G. Numerical Comparison of 3-D shapes: Potential for application to the insensate foot // *Journal of Prosthetics and Orthotics*, vol. 7, 1995, p. 29-34
14. Wang CS: An analysis and evaluation of fitness for shoe lasts and human feet. // *Comput Ind* 2010, 61(6): P. 532–540.
15. Alemany S., González J. C., García A.C. A novel approach to define customized functional design solution from user information. // *3rd Interdisciplinary World Congress on Mass Customization and Personalization*, Hong Kong, 2005.
16. Che, H., Nigg, B.M., de Koning, J., 1994. Relationship between plantar pressure distribution under the foot and insole comfort. // *Clin. Biomech*. 9, P. 335–341. doi:10.1016/0268-0033(94)90062-0
17. Jordan, C., Payton, C.J., Bartlett, R.M. Perceived comfort and pressure distribution in casual footwear. // *Clin. Biomech*. 12, 1997 doi:10.1016/S0268-0033(97)88312-X
18. Mündermann A., Nigg B.M., Stefanyshyn D.J., Humble R.N. Development of a reliable method to assess footwear comfort during running. // *Gait Posture* 16, 2002, P. 38–45. doi:10.1016/S0966-6362(01)00197-7
19. Zifchock, R.A., Davis, I. A comparison of semi-custom and custom foot orthotic devices in high- and low-arched individuals during walking. // *Clin. Biomech*. 23, 2008, P. 1287–1293.
20. B. Nácher, E. Alcántara, S. Alemany, J. García-Hernández 3D foot digitizing and its application to footwear fitting // *Instituto de biomecánica de Valencia*
21. Au EY, Goonetilleke RS A qualitative study on the comfort and fit of ladies' dress shoes. *Appl Ergon* 2007; 38(6): 687–696. <https://doi.org/10.1016/j.apergo.2006.12.002>
22. Максимчук К.Я., Чертенко Л.П., Кернеш В.П. Комплексне проектування молодіжної колекції взуття в тривимірному графічному середовищі. *Технології та дизайн* ISSN 2304-2605 No 3 (20) 2016 p., 12 с. \ Maksymchik KY, Chertenko LP, Kernesh VP Complexne proektuvannia molodizshnoii kolekcii vzuttia v tryvymirnomu grafichnomu seredovyschi. *Tecknologii ta dyzain* No 3 (20) 2016 p., 12 p. (in Ukrainian)
23. Dessery Y, Pallari J (2018) Correction: Measurements agreement between low-cost and high-level handheld 3D scanners to scan the knee for designing a 3D printed knee brace. *PLOS ONE* 13(4): e0196183. <https://doi.org/10.1371/journal.pone.0196183>