

.1.-

() -

(),));
 (),)).
)) () .
 ,
 () ,
 , ,
 1.3. :
 ,
 :
 (« »).
 ,
 :
 () - () -
 () .
 ,
 -
 ,
 2. ,
 2.1.
 2.1.1. () -
 , ()
 2.1.2. (, ,) ()
 (, ,)
 2.2.
 2.2.1.
 ,
 2.2.2.

2.2.3. (, , 1 . .) ,

2.3. (2 3 , 4 , 5 , .) ,

2.3.1. (,)

2.3.2. (,)

2.3.3. (,)

2.4.

2.4.1.

2.4.2.

2.4.3.

2.4.4. 2.4.1.-2.4.3.

2.5. ,

2.5.1. () (. . 2.1.)

2.5.2. (. . 2.2.2.)

2.5.3. -

2

() .

1
2
3
4
5



$$\Delta t = \kappa Bi = \kappa \frac{\alpha \cdot X}{\lambda} \quad (1)$$

$$\sigma = \beta \Delta t E \quad (2)$$

$$\sigma > \sigma_T^A \quad (3)$$

. 2. -

. 2: -

t

;

-

;

-

,

;

i -

(

Bio),

-

;

-

;

-

(

)

t

;

-

,

(3)

. 2

,

().

3.

()

3.1. () -

,

(),

- () () 1,

() .

,

,

,

;

);

);

);

,

,

-) « » .

1)) .

,

,

,

1

(1) 1 .

1

:

1 -

1 :

1)

() (.);

2)

()

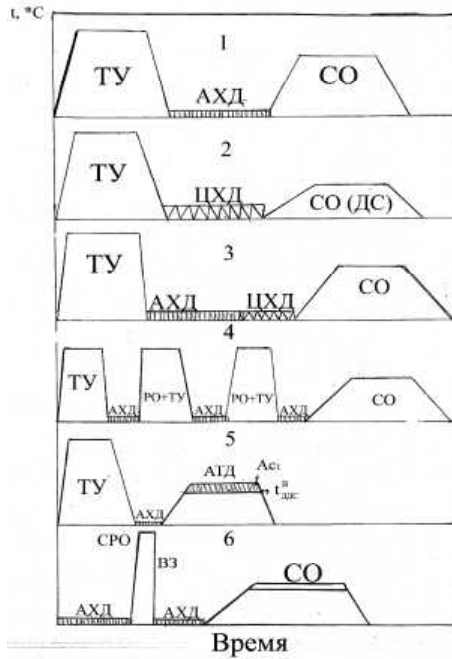

.3. –

1 – 5

6 –

6

4.

4.1.

4.1.1.

()

, . . .

4.1.2. ()

, ()

4.1.3. , ,

4.1.4.

4.1.5. -

4.2.

4.2.1. -

, ,

, ,

4.2.2. ,

, ,

4.2.3. -

, -

- -

1 ,

, ,

((),

- (()

- ()

() « »
 50% (⁵⁰ -)
)
 (. . . ⁵⁰),
 1 , ()
 - ,
 1
 ()
 (⁵⁰) **0,20%** (=
400...700 , ⁵⁰ < 273)

		/ ⁵⁰ , /K
		1,700...1,950
		2,374...2,924
		1,877...2,674
	+	2,293...3,645

,
 2 3
 - (1 .1 4 .2).
 - 5 . 3 -
 550* ,
 1. ,
 -

() 20,

	,	,	5, %	KCU**/KCV, / 2		
				t, °	+20	-40
Ø 77 . 5,5	720	760	19	1,4/1,2	1,1/0,7	1,0/0,5
Ø 60 5	610	700	23	1,8/1,7	1,6/1,4	1,5/1,2
Ø 60 40 . 3,5	550	620	21	1,5/1,3	1,2/1,1	-
Ø 60 60 . 3,5	610	700	20	1,3/1,2	1,2/1,1	-
Ø 76 3,5	607*/650	748/788	18/19	-	-	-
12	-	1050	-	0,8***	0,6***	-

* « » , -

**KCU, KCV –
*** KCU.

U- V-

20

							,	,	5, %	,	/ 2	
	t, °	° /	t, °	,	KCU ⁺²⁰	KCU ⁻⁴⁰						
-	-	920	3,0	20	600	30	515	367	20,8	54,0	0,82	0,35
	-	920	100,0	-	-	-	620	490	23,0	58,0	2,20	1,70
	1	920	70,0	20	600	40	692	560	21,0	66,7	2,03	1,17
	2	920	70,0	20	600	40	762	655	18,8	70,2	1,94	1,42
	3	920	70,0	20	600	40	810	720	17,3	67,7	1,92	1,26

0,2% , 2 - :

1 - + +

(3 .3).

2 - + +

.4, + .

:

(2) 1,8 .

(.5 .4). , 800°

2,3 ,

800°): (« » 320 200

- ()

20°)- . .5. 650° -

4

	, ,	, ,	10, %	KCU, / 2	, ,	, ,	10, %	KCU*, / 2
	338	475	33	1,7	290	365	4,5	1,1
	485	568	18,5	1,6	452	515	5,0	1,1
	610	685	21	2,0	550	665	13,0	1,4

*

1 () 2 (), (1),

T, °	0,2	,	10, %
600	780 / 570	1020 / 870	12 / 10
700	680 / 470	970 / 820	16 / 21
800	530 / 230	840 / 700	20 / 33

1 – 20%
2 – 20%

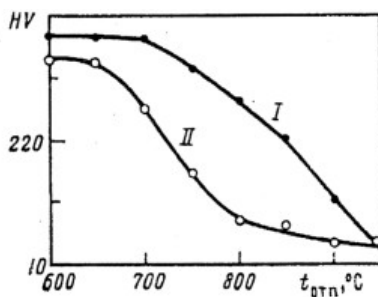

4. – (1)

1 2: I – 20% ;
II – 20%

(. 6).

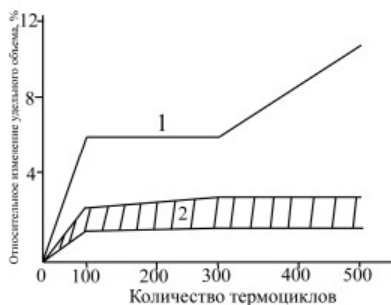

5. – : 1 – ; 2 –

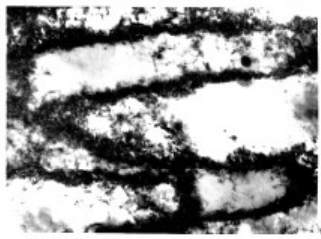

б

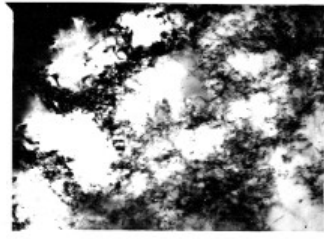

в

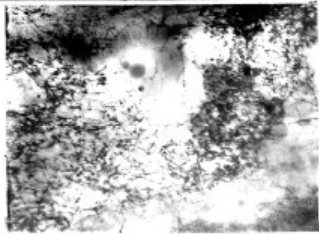

г

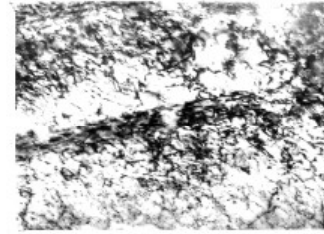

д

3),
×30000

. 6. - 20% -

; , - ; , - (

()

7,

600

- 100°

2% Ni,
2,4% Ni.

(200

) - 8.

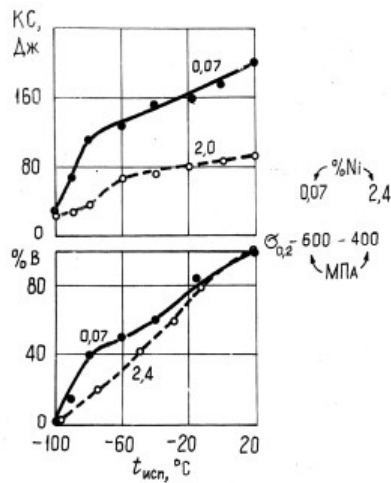

7. -

(0,07)

2 2,4% Ni



1



2

8. -

5%
(2)

(1)

5.

.3.

.9

1 .3.

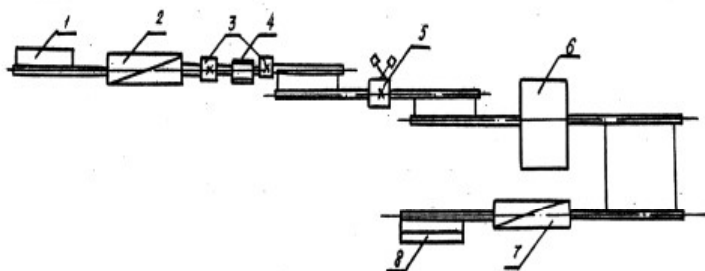

Фиг. 1.

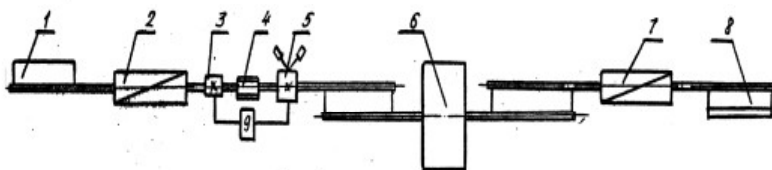

Фиг. 2.

.9.-

1

: 1 -

, 2 -

, 3 -

, 4 -

, 5 -

, 6 -

, 7 -

, 8 -

3

5

.2

9.

.10

2

.3 -

()

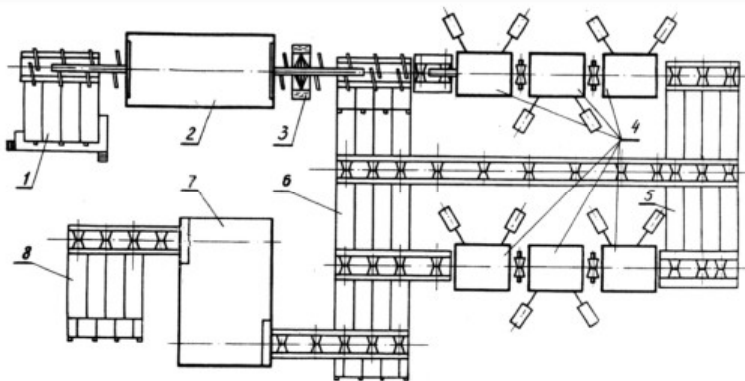

. 10. -

()
 : 1 - ;
 2 - ; 3 - ; 4 - ;
 5, 6 - ; 7 - ; 8 -

. 11

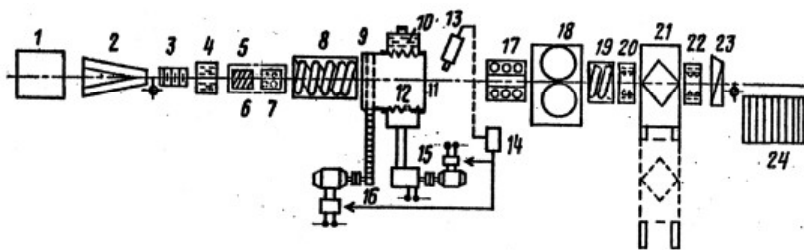

. 11. -

: 1 - , 2 - , 3 -
 - , 4 - , 5 - 7 -
 , 8 - , 9 -

, 13 – 16 –
 , 17 – – , 18 – , 19 –
 , 22 – , 20 – , 21 – , 24 –
 . 12

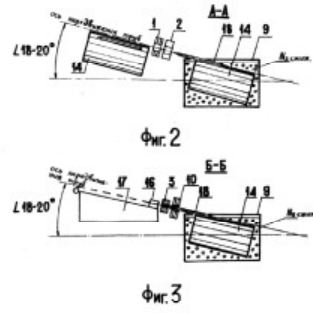
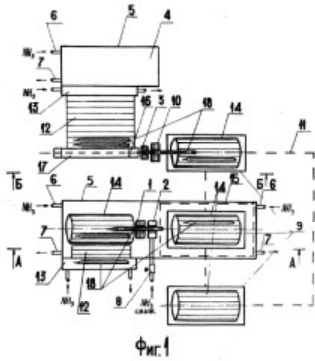

. 12. – 6

: 1 – , 2 – , 3 –
 , 4 – , 5 –
 , 6 – 7 – – , 8 –
 , 9 – – ,
 , 10 – , 11 –
 – , 12 – , 13 –
 , 14 – – , 15 – , 16 –
 , 17 – , 18 –

6

