

УДК 534.64

M. Zebian^{1,2}, M. Galovska^{2,3}, J. Hensel¹, T. Fedtke¹¹Physikalisch-Technische Bundesanstalt, Germany²International Graduate School of Metrology, Germany³Institut für Produktionsmesstechnik, TU Braunschweig, Germany

UNCERTAINTY STUDY ON THE CHARACTERISATION OF EAR CANAL PROBES

The source characterisation of an ear canal probe is commonly carried out by measurements on two or more distinct loads (calibration cavities) of known admittances. In this study, we determine the source characteristics of an Etymotic Research ear canal probe and investigate the influence of the number of the calibration cavities used. The uncertainty of these source characteristics was analysed by applying this very probe for measuring the admittance of a test cavity that was not involved in the characterisation procedure. When two calibration cavities had been employed, deviations up to 2.6 dB were noted between the measured and the theoretical admittance values of the test cavity. However, this error varied for different calibration cavity combinations and decreased to 0.3 dB in the case of four calibration cavities. Monte Carlo simulations were performed in an attempt to investigate the sensitivity of the output quantities of the source characterisation process to its input quantities (acoustic length, frequency resolution, measured sound pressure). The effect of uncertainties attributed to these input quantities proved to have no significant effect on the uncertainty of the source characteristics and, therefore, on the test cavity admittance measured by means of the probe. It was found that this error mainly depended on the choice of the calibration cavity lengths. When two sufficiently different calibration cavities were used (i.e. with a length difference greater than 4 mm), an accuracy similar to that when four cavities were used, was obtained. However, less care had to be taken on the choice of the calibration cavity lengths in the case of four cavities.

Keywords: source characterisation, measurement uncertainty, ear canal probe, calibration cavity.

Introduction

The knowledge of the ear canal acoustic input admittance is clinically useful when an assessment of the ear-canal and middle-ear functionality is required [1]. The ear canal admittance can be determined by means of a mere sound pressure measurement at its entrance, provided that an ear canal probe with known sound source parameters is used. This measurement technique involves the description of the sound source (e.g. an ear canal probe loudspeaker) by its equivalent parameters (e.g. [9]), i.e. a short-circuit volume velocity source q_s and an intrinsic admittance Y_s , according to Norton's principle.

The Norton-equivalent characteristics of the probe assembly are determined using a set of known loads (i.e. calibration cavities of known admittances). Since there are two quantities (q_s and Y_s) to be evaluated, it is necessary to employ at least two such calibration cavities with their theoretically determined admittances. While some authors used only two calibration cavities for the determination of the equivalent source characteristics of probes (e.g. [4, 7]), others employed a set of three [6] or even four [10] calibration cavities for this purpose. Using more than two cavities results in an over-determined system of equations that is apt to lead to more robust estimates of the Norton-equivalent characteristics. So far, no systematic investigation exists that describes the dependence of the source parameter uncertainty on the number of the calibration cavities to be applied for their estimation.

In this study, we analyse the impact of the number of calibration cavities on the uncertainty of the acoustic measurements of input admittances measurements performed with a source-characterised ear canal probe. First we derive the Norton-equivalent characteristics using two, three, and four calibration cavities. Then we employ a test cavity with a theoretically calculated admittance to allow a straight-forward comparison between the measured and calculated theoretical admittance results. In the end, we investigate the influence of the uncertainty of the input quantities on the output quantities, in particular on the measured acoustic admittance, using Monte Carlo simulations.

Methods

A. Norton equivalents of ear canal probes.

In this study, we derive the equivalent source characteristics of an ER-10C (Etymotic Research) ear-canal probe according to Norton's principle. This probe is commonly used for the measurement of otoacoustic emissions and consists of two miniature loudspeakers and one miniature microphone [2]. However, only one of the loudspeakers is required for the characterisation of the probe. Sound pressure measurements are carried out by the small probe microphone embedded in the probe assembly.

A sound source can be described by its equivalent characteristics (as a volume velocity source with a parallel intrinsic admittance), ([4, 8, 10]).

The first step in determining the Norton-equivalent characteristics (volume velocity source q_s and acoustic

admittance Y_S) of an ear canal probe is to measure the sound pressure responses in known acoustic loads (Fig. 1). Commonly, these loads are closed-end sound-rigid cylindrical calibration cavities having a diameter of an average human ear canal (8 mm, [11]) but different axial lengths. For cylindrical cavities of known lengths ($l_{cav,i}$ where $i = 1 \dots n$ denoting the used cavity), having sound-rigid walls and termination, the expression for the theoretical admittance ($Y_{cav_th,i}$) is:

$$Y_{cav_th,i} = Y_0 \tanh(\gamma l_{cav,i}), \quad (1)$$

where Y_0 denotes the acoustic wave admittance of the transmission line and γ is the complex propagation coefficient, taking the thermoviscous boundary layers into account, according to Keefe (1984) [5]. The length of the i^{th} cavity is denoted by $l_{cav,i}$ and its inner diameter by $d_{cav,i}$.

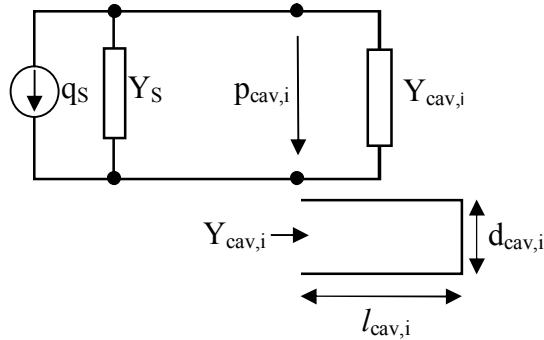

Fig. 1. Analogous electro-acoustic circuit of an ear canal probe described by its Norton equivalents (q_s and Y_S) and terminated by calibration cavities of known lengths $l_{cav,i}$ and acoustic admittances $Y_{cav,i}$ ($i = 1 \dots n$)

The theoretical cavity admittance $Y_{cav_th,i}$ and the cavity pressure $p_{cav,i}$ measured by the probe are related to the source volume velocity q_s and the source admittance Y_S by the following equation [10]:

$$\frac{p_{cav,i}}{q_s} = \frac{1}{Y_S + Y_{cav_th,i}}. \quad (2)$$

The two complex quantities (q_s and Y_S) are to be evaluated at each frequency. Consequently, the use of at least two cavities is required with their model admittances $Y_{cav_th,i}$ (cf. Eqs. 1 and 2). If more than two cavities are used, then we obtain an over-determined system of equations:

$$\begin{pmatrix} q_s \\ Y_S \end{pmatrix} = \begin{pmatrix} \frac{1}{p_{cav,1}} & -1 \\ \dots & \dots \\ \dots & \dots \\ \frac{1}{p_{cav,n}} & -1 \end{pmatrix}^{-1} \cdot \begin{pmatrix} Y_{cav_th,1} \\ \dots \\ \dots \\ Y_{cav_th,n} \end{pmatrix}. \quad (3)$$

The Norton equivalents (q_s and Y_S) are evaluated at each frequency, using a least-squares method to solve this over-determined system of equations. Note that a pseudo-inverse is generated for the non-square matrix, denoted by $()^{-1}$.

Once the Norton equivalents are determined, the acoustic input admittance of any unknown test load Y_{cav_test} (e.g. admittance of a human ear canal) can be obtained with a sole sound pressure measurement p_{cav_test} :

$$Y_{cav_test} = \frac{q_s}{p_{cav_test}} - Y_S. \quad (4)$$

B. Calibration cavity sets.

The calibration cavities were chosen to be acoustically rigid cylindrical acrylic glass tubes having an inner diameter of $d_{cav} = 8$ mm. The cavity lengths $l_{cav,i}$ were acoustically determined using the relation:

$$l_{cav,i} = \frac{c}{4f_{q,i}}, \quad (5)$$

where c is the sound speed in air at room temperature, and $f_{q,i}$ corresponds to the first antiresonance quarter-wavelength frequency of the i^{th} -cavity.

The frequency responses (L_{cav} in dB re $20\mu\text{Pa}$) of the four calibration cavities used in this study are depicted in Fig. 2.

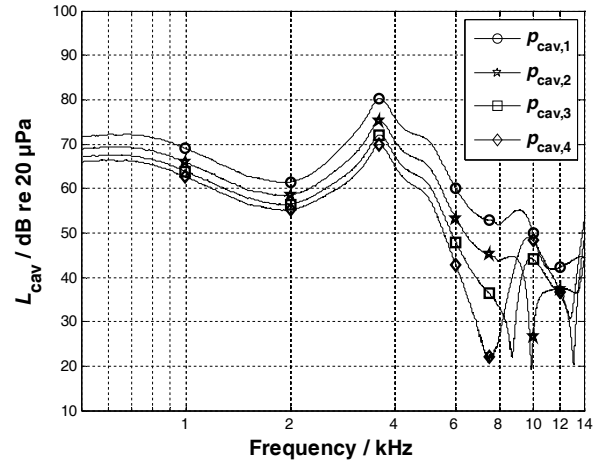

Fig. 2. Frequency responses of the calibration cavities: $L_{cav} = 20 \lg(p_{cav,i}/p_0)$ where $p_0 = 20\mu\text{Pa}$. The acoustic lengths of the cavities are derived from the quarter-wavelength frequencies $f_{q,i}$ of these curves

From the spectral zeros in the frequency responses of the cavities (Fig. 2), the quarter-wave frequencies can be estimated. From Eq. 5, the acoustic lengths of the cavities can be obtained (Table 1).

Table 1

A set of four cavities ($i = 1 \dots 4$) with the corresponding acoustically determined lengths in mm

Cavity: i	$l_{cav,i} / \text{mm}$
1	5.23
2	8.77
3	9.99
4	11.67

To assess the accuracy of the obtained Norton equivalents, a test cavity is required which is not involved in the calibration procedure. A test cavity of an acoustic length $l_{cav_test} = 30.73$ mm was chosen for this purpose.

Results and Discussion

A. Norton equivalents of ER-10C probe.

In Fig. 3, the Norton equivalents (Y_S and q_S) of the ER-10C probe obtained from two (C_2 : cavities 1 and 2), three (C_3 : cavities 1, 2, and 4), and four calibration cavities (C_4 : cavities 1, 2, 3, and 4) are exemplarily shown along with their corresponding phases.

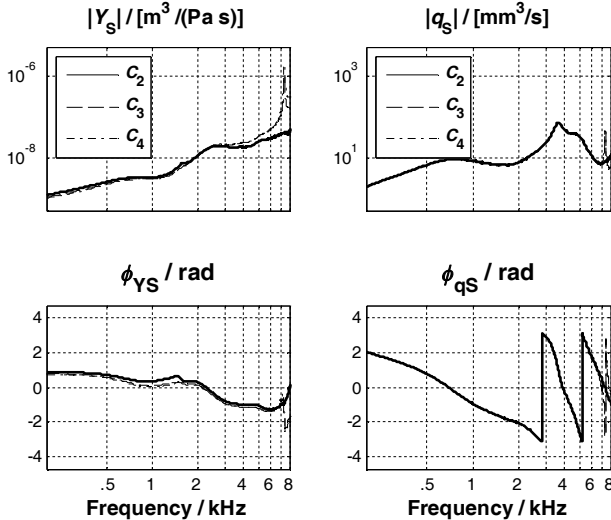

Fig. 3. Norton equivalents of the ER-10C probe: Source admittance Y_S and the volume velocity q_S (upper panels) with their corresponding phases ϕ_{Y_S} and ϕ_{q_S} (lower panels). The chosen calibration cavity sets were: C_2 (cavities 1, 2), C_3 (cavities 1, 2, 4), C_4 (cavities 1, 2, 3, 4). Legends in the lower panels were omitted for lucidity

As seen from Fig. 3, the Norton-equivalent source characteristics depended on the number of the calibration cavities applied and their corresponding acoustic lengths. However, irrespective of the lengths and the number of the calibration cavities used, the Norton equivalents showed similar characteristics in the lower frequency range. Discrepancy in the higher frequency range is explained by the restriction caused by the quarter-wavelength frequency of the longest calibration cavity used. Thus, comparisons should only be undertaken at frequencies well below this limit.

For the set of cavities employed in this study, the quarter-wavelength frequency of the longest cavity ($l_{cav,4} = 11.67$ mm) is about 7.4 kHz (the reason for the spectral pole seen in Y_S in Fig. 3 for C_3 and C_4). As a result, we chose to analyse our results only up to 4 kHz, which is adequately below this critical frequency.

B. Acoustic admittance of a test cavity.

To assess the accuracy of the obtained Norton equivalents, a cavity is required that was not involved in the source characterisation process. A cylindrical test cavity having an acoustic length of $l_{cav_test} = 30.73$ mm was chosen for this purpose.

We applied the different complex source characteristics (see Fig. 3 and Appendix A) to obtain an

indirect estimate of the acoustic admittance by measuring the sound pressure in the test cavity and solving Y_{cav_test} in Eq. 4. The results, depicted in Fig. 4, allow an estimate of the measurement accuracy by a straight-forward comparison of the measured acoustic admittances (using the different source characteristics of Fig. 3) with the theoretically calculated values. The thick dashed line represents the theoretical cavity admittance.

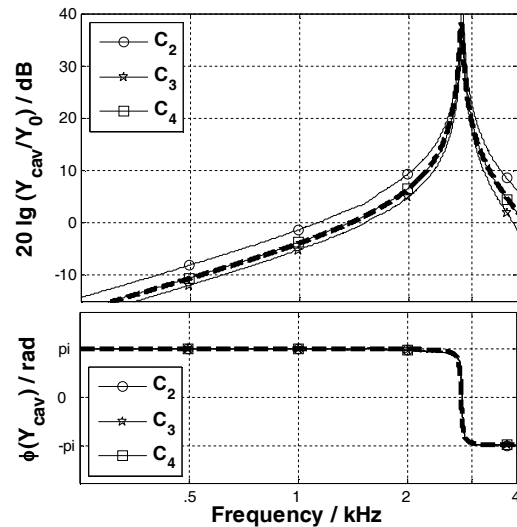

Fig. 4. Magnitude and phase of the admittance Y_{cav} of the test cavity ($l_{test_cav} = 30.73$ mm) estimated from the Norton equivalents of Fig. 3 applying Eq. 4. Combinations of two (C_2), three (C_3), and four (C_4) calibration cavities were applied by the source characterisation. Thick dashed line corresponds to the theoretical admittance

To acquire a deeper insight into the obtained results, the deviations of the measured admittances (Fig. 4) from the theoretical admittance (Eq. 1) are shown in Fig. 5.

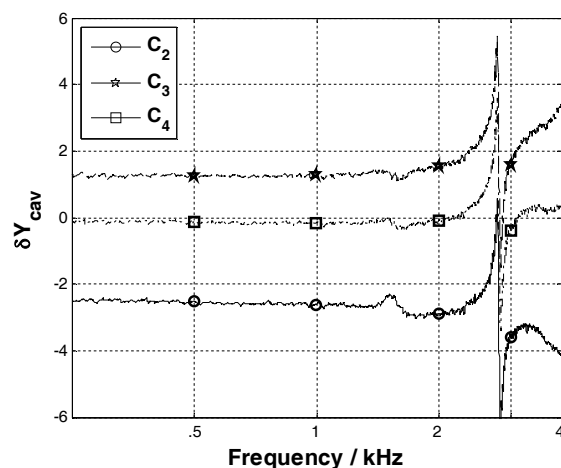

Fig. 5. Deviation δY_{cav} (in dB) between theoretical and measured admittance (from Fig. 4) of the 30.73 mm acoustically long test cavity

The estimation of the admittance differed from the theoretical values by up to 2.6 dB, except for frequencies in the vicinity of the spectral pole at 2.8 kHz, where these

deviations amounted to up to 6 dB. It is worth mentioning that no significant differences in the phase were observed (Fig. 4, lower panel).

C. Uncertainty analysis.

For the purpose of analysing the accuracy of the obtained results, the measured acoustic admittance $Y_{\text{cav_meas}}$ in the frequency range under study is described by the following equation:

$$Y_{\text{cav_meas}}(C_k, f_j) = Y_{\text{cav_th}}(C_k, f_j) + \theta_{\text{sys}}(C_k, f_j) + \varepsilon_{\text{rand}}(C_k, f_j),$$

where C_k ($k = 2, 3$, or 4 cavities) denotes a cavity combination used for determining the Norton equivalents, $Y_{\text{cav_th}}$ represents the theoretical admittance (Eq. 1), θ_{sys} comprises the systematic effects and $\varepsilon_{\text{rand}}$ the random effects.

For all studied combinations, especially for C_2 and C_3 , a constant shift θ_{sys} was observed over frequency aside from the region of the spectral pole (Fig. 5):

$$\theta_{\text{sys}}(C_k, f_j) = \theta_{\text{sys}}(C_k) = \text{const.}$$

This shift varied, however, for different calibration cavity sets.

The random error $\varepsilon_{\text{rand}}$ evaluated over the entire frequency range under study ($\ll f_{q,4}$) did not vary for different calibration cavity sets as long as the number of cavities involved was constant. This random error was characterised by the respective standard deviation as:

$$SD_{\text{rand}} = \sqrt{\frac{1}{N-1} \sum_{j=1}^N (e'_{\text{rand}}(f_j) - \bar{e}'_{\text{rand}})^2}, \quad (6)$$

where

$$e'_{\text{rand}}(f_j) = Y_{\text{cav_meas}}(f_j) - Y_{\text{cav_th}}(f_j) - \theta_{\text{sys}}$$

$$\text{and } \bar{e}'_{\text{rand}} = \frac{1}{N} \sum_{j=1}^N e(f_j).$$

With the increased number of calibration cavities, the respective standard deviation (Eq. 6) decreased: e.g.: $SD_{\text{rand}}(C_2) = 0.49$ dB; $SD_{\text{rand}}(C_3) = 0.23$ dB; $SD_{\text{rand}}(C_4) = 0.17$ dB.

Fig. 6 shows the measured admittance deviations from theoretical values. The measured admittances were obtained from the different combinations of the calibration cavities (please refer to Appendix A).

The maximal deviation was reduced from 2.6 dB (using calibration cavity set C_2) to approximately 0.25 dB (using C_4), whereas the minimal deviation was also about 0.25 dB and did not depend on the number of the calibration cavities used.

The indirect method to measure the acoustic admittance provides a number of challenges that we intend to analyse. This process allows both a nonlinear redundant and a non-redundant measurement. For the analysis of the measurement uncertainty, we applied Monte Carlo simulations [3], which was necessary for two reasons: the nonlinearity of the applied

measurement method and; the use of the least-squares method for the redundant measurement (C_k where $k > 2$) for which no recommendation exists in the basic part of the Guide to the Expression of Uncertainty in Measurement (GUM) so far.

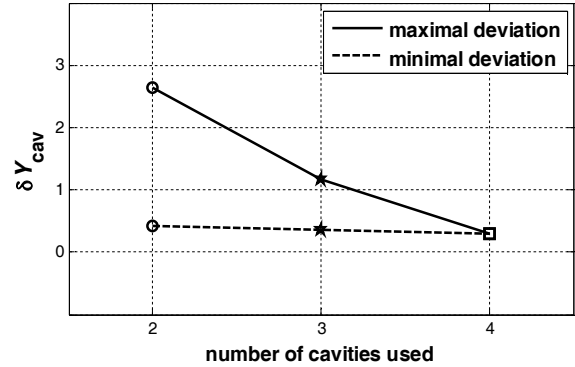

Fig. 6. Maximal and minimal deviations δY_{cav} (in dB) of the acoustic admittance over the number of the calibration cavities used for the source characterisation evaluated at $f = 1500$ Hz

In a first step, the sensitivity of the admittance Y_{cav} to the uncertainty of the acoustic length (Eq. 1) was assessed. In a second step, the sensitivity of the output quantities (Y_s and q_s) to the uncertainty of the input quantities (Y_{cav} and p_{cav}) was analysed.

Step 1: Sensitivity of admittance.

Sensitivity of acoustic length to frequency resolution. The obvious source of uncertainty of the determination of the acoustic length is the frequency resolution of the recorded frequency responses. In this study, a frequency resolution of 1 Hz was used. Monte Carlo simulations were performed to quantify this effect on the acoustic length estimation (discretisation error).

This was analysed using Eq. 5 and assuming that the uncertainty of f_q has a uniform distribution with the limits $\Delta f_q = \pm 0.5$ Hz. The uncertainty of the acoustic length attributed to the frequency resolution was found to be $SD(f_q) = 0.0031$ mm. Compared to the standard deviation: $SD(l_{\text{rep}}) = 0.18$ mm (obtained from ten consecutive acoustic length measurements of the test cavity), the uncertainty of the length due to the frequency resolution was considered to be negligible, since $SD^2(f_q) < SD^2(l_{\text{rep}})/10$.

Sensitivity of admittance to acoustic length. Although the effect of the frequency resolution on the uncertainty of the cavity length is negligible, other factors might influence the length to a more severe extent. As mentioned above, the length uncertainty, attributed to reproducibility measurements on the test cavity, was $SD(l_{\text{rep}}) = 0.18$ mm.

Hence, Monte Carlo simulations were performed to analyse the length uncertainty on the cavity admittance according to Eq. 1. In this case, a normal

distribution was assumed. Aside from the peak region (around 2.8 kHz) the sensitivity of the admittance to the length uncertainty was considered to be negligible ($SD_{Y_{cav}(l_{rep})} = 0.005$ dB) compared to the uncertainties in the acoustic admittance (e.g. $SD_{rand}(C_4) = 0.17$ dB).

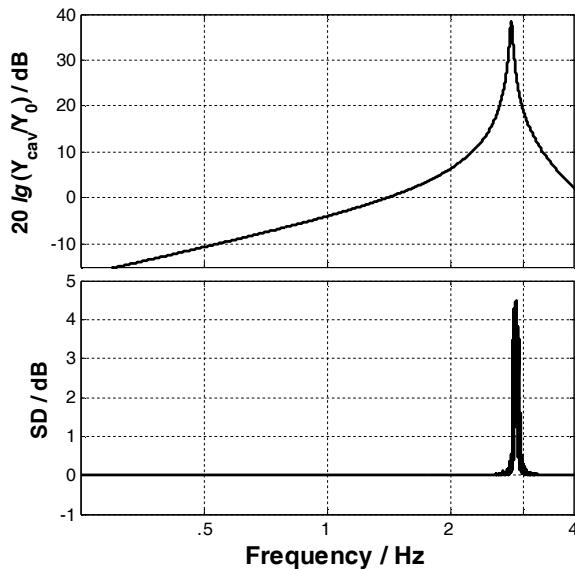

Fig. 7. Upper panel: Theoretical admittance Y_{cav} of the test cavity ($l_{cav_test} = 30.73$ mm). Lower panel: Standard deviation of the mean of Y_{cav} in dB as derived from Monte Carlo simulations taking the standard deviation $SD(l_{rep}) = 0.18$ mm of reproducibility length measurements into account

Step 2: Sensitivity of source characteristics/

In this section we analyse the sensitivity of the source characteristics (q_s, Y_s) to the uncertainty of the input quantities (p_{cav}, Y_{cav}). Monte Carlo simulations were carried out assuming a normal distribution and accounting for the number of equations used to solve the source characteristics. The sensitivity of the source characteristics to the input component uncertainty $SD(p_{cav}) = 0.04$ dB (obtained from sound pressure curves) is shown in Table 2 for different numbers of calibration cavities.

Table 2

Standard deviation of the source characteristics obtained using two, three, and four calibration cavities, depending on the influence of the input uncertainty of the measured sound pressure p_{cav} .

Number of cavities	$SD(Y_s) / \text{dB}$	$SD(q_s) / \text{dB}$
2	0.058	0.012
3	0.045	0.007
4	0.038	0.006

These negligible standard deviations agree with the fact that the probe microphone has an almost flat frequency response up to 10 kHz. Similar behaviour was noted for the sensitivity to Y_{cav} .

Since both Y_s and q_s depend on the same input components, we considered the correlation between their uncertainties. Fig. 8 shows the two-dimensional joint distribution of both the source admittance Y_s and the source volume velocity q_s along with the covariance matrix $\text{cov}(Y_s, q_s)$.

The correlation between the output quantities (Y_s and q_s) was found to be higher than 0.9 for all combinations of the cavity sets investigated.

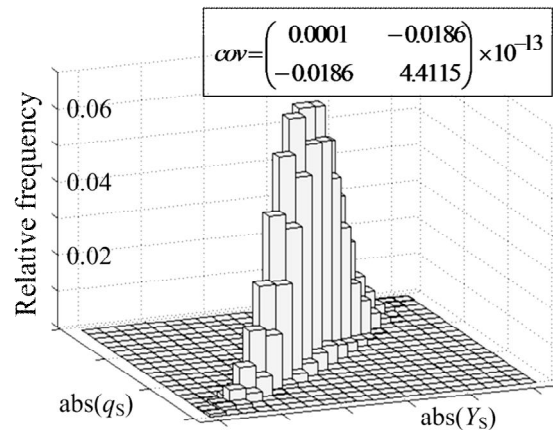

Fig. 8. Histogram representing the two-dimensional joint distribution of the source characteristics q_s and Y_s

D. Assessment of Results.

The uncertainties of the investigated components did not significantly contribute to the deviations between the predicted and the measured test cavity admittances, found for some two-cavity combinations (see Appendix A). However, we observed that for certain combinations of two cavities, the obtained results were as good as those achieved from the four-cavity combination (compare minimal deviations in Fig. 6). However, for the four-cavity combination, the random error, characterised by $SD_{rand}(C_4) = 0.17$ dB, comprised the major part of the total error ($\delta Y_{cav} \approx 0.25$ dB, Fig. 6). It is expected that this error would diminish should even more calibration cavities be applied.

This led us to conclude that, in the case of a two-calibration cavity set, the choice of their relative lengths was the main source for this error.

Analysing the deviation between the predicted and the measured test cavity admittance resulting from each of the two-cavity combinations (Appendix B), the best result was obtained in the case where the shortest ($l_{cav,1} = 5.23$ mm) and the longest calibration cavity ($l_{cav,4} = 11.67$ mm) were employed in the characterisation process. These two cavities differed by about 6.4 mm in length.

On the other hand, the poorest result came from the combination of the middle-length cavities ($l_{cav,2} = 8.77$ mm) and ($l_{cav,3} = 9.99$ mm) that differed from each other by only 1.2 mm.

From these findings, it could be deduced that the accuracy is highly dependent on the choice of the calibration cavity lengths. This comes in accordance with the recommendation that the theoretical admittances of the calibration cavities chosen should be sufficiently different [6]. From this study, we recommend that a difference between the calibration cavity lengths of at least 4 mm should be applied to achieve results comparable to those obtained from four cavities.

A practical recipe for the source characterisation of an ear canal probe (with which a significant reduction in uncertainty can be obtained) is:

- (i) use more than two calibration cavities for the source characterisation,
- or,
- (ii) meet the 4 mm criterion for the choice of the cavity lengths.

Conclusion

The Norton-equivalent source characteristics of an ER-10C (Etymotic Research) ear canal probe were determined using different sets of calibration cavities. The admittances of an arbitrarily chosen test cavity were estimated using these source characteristics. The accuracy of the results notably improved with an increased number of the calibration cavities.

The use of two calibration cavities resulted in a good estimate of an “unknown” test cavity admittance (deviation from theoretical considerations less than 0.3 dB) only if the calibration cavity lengths differed by at least 4 mm. This same accuracy was achieved using four calibration cavities without the mentioned criterion concerning the choice of the cavity lengths.

For acoustic measurements within the human ear canal, this accuracy of the source characterisation is deemed adequate, compared to the much higher inaccuracies which occur during in-situ measurements on test subjects.

Acknowledgements

We wish to thank Sara Zebian for her valuable comments on this manuscript. Special thanks to Christina Imbery for implementing the Norton-equivalent characterisation procedure in MATLAB and Serkan Canaran for the production of the acrylic glass tubes.

Appendix

A. The admittances of the test cavity using the source characteristics obtained from all the combinations of the calibration cavity set (of Table 1) are shown in the following figures (Figs. A.1, A.2, A.3). The thick dashed line corresponds to the theoretical admittance.

B. The admittances obtained for two calibration cavity combinations (best- and worst case, Fig. B.1).

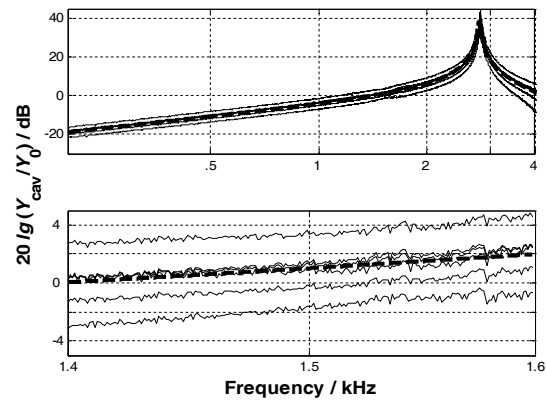

Fig. A.1. Top: The acoustic admittances measured using the source characteristics obtained by employing all possible combinations of two cavities from the calibration cavity set used in this study (please refer to cavities $i = 1 \dots 4$ in Tab. 1), i.e. 6 combinations. Bottom: A close-up in the admittance curves of the upper panel around the frequency 1.5 kHz. The thick dashed line represents the theoretical admittance

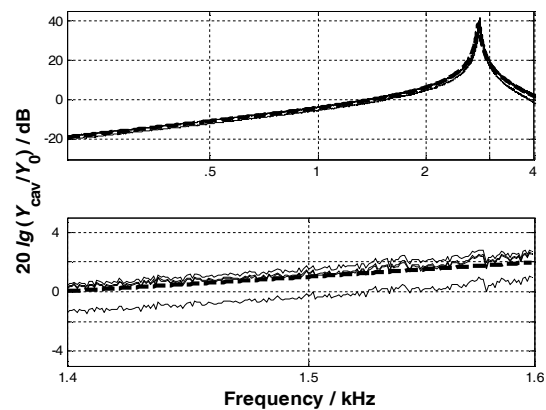

Fig. A.2. Top: The acoustic admittances measured using the source characteristics obtained by employing all possible combinations of three cavities from the calibration cavity set of Table 1, i.e. 4 combinations. Bottom: A close-up in the admittance curves of the upper panel around the frequency 1.5 kHz. The thick dashed line represents the theoretical admittance

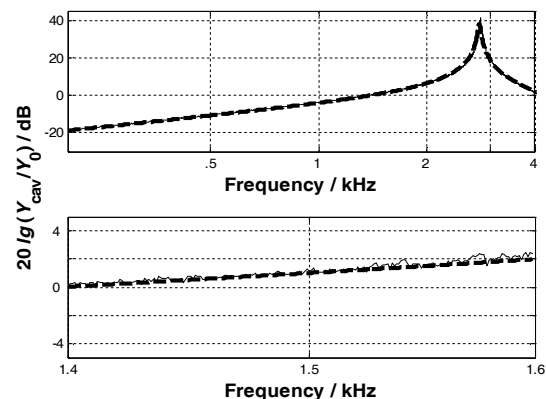

Fig. A.3. Top: The acoustic admittance measured using the source characteristics obtained by employing all the four calibration cavities. Bottom: A close-up in the admittance curve of the upper panel around the frequency 1.5 kHz. The thick dashed line represents the theoretical admittance.

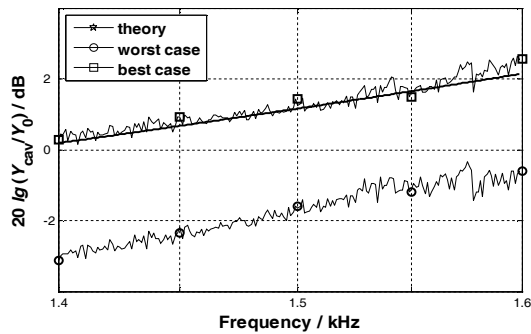

Fig. B.1. A close-up in a 200-Hz wide frequency range of the test cavity admittance obtained using the calibration cavity combination ($l_{cav,1}$ and $l_{cav,4}$) that resulted in the best admittance estimates (-□-) and using the combination ($l_{cav,2}$ and $l_{cav,3}$) that yielded the worst admittance estimates (-○-). The thick dashed line represents the theoretical admittance

Literature list

1. Allen J.B. Evaluation of human middle ear function via an acoustic power assessment / J.B. Allen, P.S. Jeng, H. Levitt // *JRRD* 42. – 2005. – P. 63-78.
2. Etymotic Research ER-10C, DPOAE probe, <http://www.etymotic.com/pro/er10c-acc.aspx>, 2010.
3. GUIDE 98-3/Suppl. 1. Uncertainty of measurement. Part 3: Guide to the expression of uncertainty in measurement (GUM: 1995). Supplement 1: Propagation of distributions using a Monte Carlo method.
4. Huang G.T. A non-invasive method for estimating acoustic admittance at the tympanic membrane / G.T. Huang, S.P. Rosowski, W.T. Peake // *J. Acoust. Soc. Am.* 108. – 2000. – P. 1128-1146.
5. Keefe D.H. Acoustical wave propagation in cylindrical ducts: Transmission line parameter approximations for isothermal and nonisothermal boundary conditions / D.H. Keefe // *J. Acoust. Soc. Am.* 75. – 1984. – P. 58-62.
6. Ludwig A. Ein System zur Anpassung von Hörgeräten – Messtechnik, patientenbezogene Modellierung, Optimierung der Komponenten / A. Ludwig. – Shaker Verlag, 1998.
7. Oswald J.A. Objektive Audiometrie mit otoakustischen Emissionen und akustisch evozierten Potenzialen / J.A. Oswald. – PhD thesis, TU-München, 2005.
8. Influence of in situ, sound-level calibration on distortion-product otoacoustic emission variability / R.A. Scheperle, S.T. Neely, J.G. Kopun, M.P. Gorga // *J. Acoust. Soc. Am.* 124. – 2008. – P. 288-300.
9. Schmidt S. Accuracy of acoustic ear canal impedances: Finite element simulation of measurement methods using a coupling tube / S. Schmidt, H. Hudde // *J Acoust Soc Am* 125. – 2009. – P. 3819-3827.
10. Voss S.E. Measurement of acoustic impedance and reflectance in the human ear canal / S.E. Voss, J.B. Allen // *J. Acoust. Soc. Am.* 95. – 1994. – P. 372-384.
11. Zebian M. A finite element model of an average human ear canal to assess calibration errors of distortion product otoacoustic emission probes / M. Zebian // *Proceedings of the 3rd International Competition "The best young metrologist of COOMET 2009"*. – Minsk, 2009. – P. 69-74.

Надійшла до редколегії 16.12.2010

Рецензент: д-р техн. наук, проф. І.П. Захаров, Харківський національний університет радіоелектроніки, Харків.

ДОСЛІДЖЕННЯ НЕВИЗНАЧЕНОСТІ ОЦІНЮВАННЯ ХАРАКТЕРИСТИК ЗОНДУ СЛУХОВОГО КАНАЛУ

М. Цебіан, М. Гальовська, Й. Хензель, Т. Федтке

Визначення характеристик джерела слухового проходу, як правило, проводиться шляхом вимірювань при двох і більше навантаженнях з відомими значеннями провідності. У даній роботі визначаються характеристики джерела зонду слухового проходу Etymotic Research і досліджується вплив числа використовуваних калібрувальних порожнин на результат. Проаналізовано невизначеність оцінок цих характеристик з використанням додаткової контрольної порожнини, яка не бере участі в процедурі оцінювання. При використанні двох калібрувальних порожнин спостерігалось відхилення від теоретичного значення, що досягало 2,6 дБ. Похибка значно зменшується при збільшенні числа порожнин, і складає 0,3 дБ при використанні чотирьох. Моделювання методом Монте-Карло дозволило провести дослідження впливу окремих входних величин моделі (акустична довжина, дозвіл по частоті, звуковий тиск) на оцінки параметрів. Проаналізовані складові невизначеності виявилися малими, але на результат надає вплив співвідношення значень довжини калібрувальних порожнин. У випадку досить великої різниці значень довжини двох порожнин (більше 4 мм), можливо досягти високої точності, порівнянної із застосуванням чотирьох порожнин. Таким чином, використання більшої набору порожнин дозволяє знизити вимоги до них.

Ключові слова: оцінювання характеристик джерела, невизначеність вимірювання, зонд слухового каналу, калібрувальна порожнина.

ИССЛЕДОВАНИЕ НЕОПРЕДЕЛЕННОСТИ ОЦЕНИВАНИЯ ХАРАКТЕРИСТИК ЗОНДА СЛУХОВОГО ПРОХОДА

М. Цебиан, М. Галевская, Й. Хензель, Т. Федтке

Определение характеристик источника слухового прохода, как правило, проводится путем измерений при двух и более нагрузках с известными значениями проводимости. В данной работе определяются характеристики источника зонда слухового прохода Etymotic Research и исследуется влияние числа используемых калибровочных полостей на результат. Проанализирована неопределенность оценок этих характеристик с использованием дополнительной контрольной полости, не участвующей в процедуре оценивания. При использовании двух полостей наблюдалось отклонение от теоретического значения, достигавшее 2,6 дБ. Погрешность значительно уменьшается при увеличении числа калибровочных полостей, и составила 0,3 дБ в случае четырех. Моделирование методом Монте-Карло позволило провести исследование влияния отдельных входных величин модели (акустическая длина, разрешение по частоте, звуковое давление) на оцениваемые параметры. Анализируемые составляющие неопределенности оказались пренебрежимо малыми, но на результат оказывает влияние соотношение значений длины калибровочных полостей. В случае достаточно большой разницы значений длины двух полостей (более 4 мм), возможно достигнуть высокой точности, сравнимой с применением четырех полостей. Таким образом, использование большего набора полостей позволяет снизить требования к их длинам.

Ключевые слова: оценивание характеристик источника, неопределенность измерения, зонд слухового прохода, калибровочная полость.