

**A COMPARISON OF PHASE REFLECTOMETRY METHODS  
FOR LOCATION FAULT IN TELECOMMUNICATION CABLES**

**Abstract.** Aging wiring in buildings, transportation systems, consumer products and industrial machinery is among the most significant potential causes of catastrophic failure and maintenance cost in these structures. Smart wire monitoring can therefore have a substantial impact on the overall health monitoring of the system.

Well known reflectometry is commonly used for locating faults on wires and cables for a long time. This paper compares Time domain reflectometry (TDR), frequency domain reflectometry (FDR), mixed signal reflectometry (MSR), sequence time domain reflectometry (STDR), spread spectrum time domain reflectometry (SSTDR) in terms of their accuracy, convenience, cost, size, and ease of use. Advantages and limitations of each method are outlined and evaluated for cables. The results in this paper can be extrapolated to other types of wire and cable systems

**Keywords:** electrical wiring; reflectometry; nondestructive evaluation; aircraft maintenance.

К.Л. ГОРЯЩЕНКО, О.Е. ЗЕМЛЯНСЬКИЙ  
Хмельницький національний університет, Україна

**ПОРІВНЯННЯ ФАЗОВИХ РЕФЛЕКТОМЕТРИЙНИХ МЕТОДІВ  
ДЛЯ ВИЯВЛЕННЯ ПОШКОДЖЕНЬ В ЕЛЕКТРОКОМУНІКАЦІЙНИХ КАБЕЛЯХ**

Старіння електропроводки в будівлях, транспортних системах, споживчих товарах та промислових машинах є однією з найважливіших потенційних причин катастрофічних збоїв та витрат на обслуговування в цих структурах. Чіткий моніторинг проводів може суттєво вплинути на загальний моніторинг стану системи.

Добре відома рефлектометрія зазвичай використовується для визначення несправностей на проводах і кабелях протягом тривалого часу. У цій роботі порівнюється рефлектометрія часового поясу (TDR), рефлектометрія частотної області (ФДР), змішана сигнальна рефлектометрія (MSR), рефлектометрія часового домену послідовності (STDR), рефлектометрія часового поясу розсіяного спектра (SSTDR) з точки зору їх точності, зручності, вартості. Розмір і простота використання. Переваги та обмеження кожного методу наведені та оцінені для кабелів. Результати в цьому документі можуть бути екстрапольовані на інші типи дротових та кабельних систем

Ключові слова: електропроводка; Рефлектометрія; Незруйнована оцінка; Технічне обслуговування літальних апаратів.

**1. Introduction**

Aging electrical systems are prevalent in today's society. A full scale evaluation of the problem is difficult. Wiring was not normally considered in lifecycle maintenance. Over 90% of home fires are attributed to electrical fires, although it is not clear how many are due to installed wiring and how many to faulty plug-in consumer devices. In addition to the safety problem, aircraft wiring systems are a maintenance burden. For example known that between 1 million and 2 million man-hours are required at the operational level to troubleshoot and repair wiring system problems in the U.S. Navy alone each year. Highly trained technicians trouble shoot wiring problems using diagnostics methods that are many years old.

Visual inspection, the most common traditional method, was determined to be insufficient to find fault. Especially hard to find faults in hidden wires. Time domain reflectometry (TDR), another traditional method for locating faults, was found to be enough accurate but difficult to use [1, 2, 3].

High voltage test systems are able to locate even small faults, however they are very large and expensive. Also, high voltage testing methods are able to reduce lifetime of wires or even create new faults [1, 2, 3]. That's why new methods are needed, and development funds have led to the emergence of a number of different techniques. In article described wire test methods that are suitable for handheld and compares their advantages and disadvantages.

The methods compared are the time domain reflectometer (TDR), frequency domain reflectometer (FDR), mixed signal reflectometer (MSR), sequence time domain reflectometer (STDR), spread spectrum time domain reflectometer (SSTDR) [4, 5, 6, 7].

**2. Test methods****2.1 Time domain reflectometry**

One of the most known method – Time domain reflectometry (TDR). TDR is most commonly used method for testing wires. use a high frequency electrical signal down the wire, where it reflects from any impedance discontinuity. The reflection coefficient gives a measure of how much signal is returned.

The time or phase delay between the incident and reflected signals tells the distance to the fault, and the observed magnitude of the reflection coefficient tells what the impedance of the fault.

Faults like open or short are observable by TDR without any problems. But soft faults like damaged insulation, etc. are generally founded not so easy. The height of the peak relative to the maximum peak height gives the reflection coefficient.

The delay between the incident and reflected voltages shows up in the location of reflectometry peaks. The distance  $L$  is the velocity of propagation divided by the time delay. The velocity of propagation in typical aircraft cables ranges from 0.5 to 0.8 depending on the type of cable. It is therefore very important to know the type of wire being tested. The velocity is dependent on the size and shape of the conductors, and therefore also depends on the distance between conductors.

Common problems of TDR are the inability to see small reflections and errors in the velocity of propagation are sources of errors. Other sources of errors in TDR are hardware errors – classical measurement error, where some variation in measurements is seen, even without making any changes to the wire under test, its connection, etc.

For the reflectometry methods described below, this is generally less than 1%. Another error is connection error. Since the reflectometer must be connected to a wide variety of cables, it is not generally so easy to match the impedance of the reflectometer output with the wire. This means there will always be a reflection between the measuring board and the wire being tested. The test-lead, connectors, adapters, etc. all add to this reflection in different ways. The physical connection to the wire is not always identical, and this difference gives an error of about 30 sm with 10 meters long wire.

Another significant source of error in reflectometry methods that is quite important to testing wires is the so-called "blind spot" for wires that are very short. This is caused by the reflected signal overlapping the incident signal, because the time delay between generating short pulse and measuring of reflections is so small.

This makes it difficult to identify the reflected signal. Two methods can be used to reduce this problem. One is to use a longer test lead to connect the reflectometer to the wire under test. This would effectively delay the reflected signal enough that the overlap can be reduced or avoided. This may be practical for handheld applications, but it is not practical for embedded applications.

**2.2. Time domain reflectometry (TDR)**

Frequency domain reflectometry (FDR) uses a set of stepped sine waves. Sequence time domain reflectometry (STDR) uses a pseudo noise (PN) sequence as the incident signal, and spread spectrum time domain reflectometry (SSTDR) uses a sine wave modulated PN code. Noise domain reflectometry (NDR) uses no signal at all, but rather only existing signal and its inherent noise on the wire.

The accuracy of TDR is controlled by the rise time of the pulse and the sampling rate of the receiver.

TDR requires a fast rise time pulse generator and fast sampler. It is difficult to control the problem of "blind spots" with this method, except by adding a length of cable to the test lead. But must be noted parameters of cable must be exactly equal to wire to be tested. Also this method has limited application on wires that are used. If the wire is carrying a low frequency signal (400 Hz power, for instance), it is feasible to use TDR to test the wire while it is live. The TDR signal would need to be small enough to be below the noise margin of the signals. This

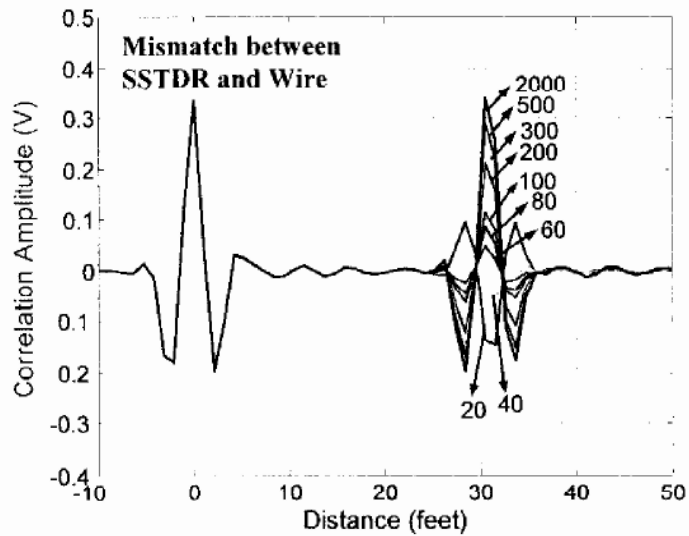

Fig. 1 Spread spectrum time domain reflectometry (SSTDR) responses for different load impedances (given in ohms for a 50Ω2 wire). The correlation amplitude is proportion to reflection coefficient. Other reflectometry methods will have the same relative peak magnitudes, but different shapes of the pulses

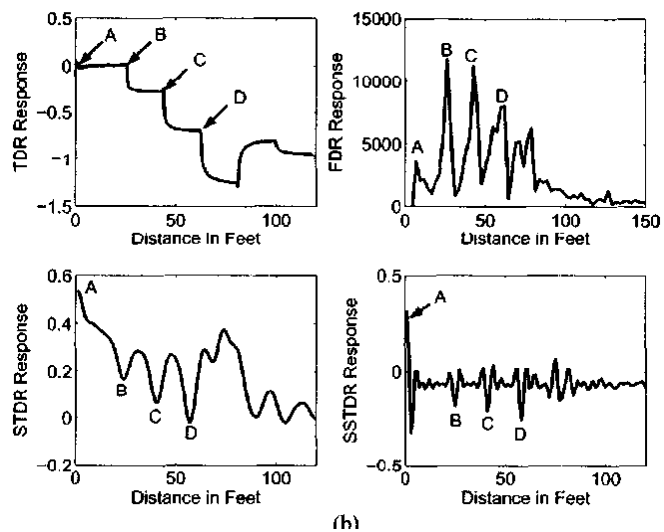
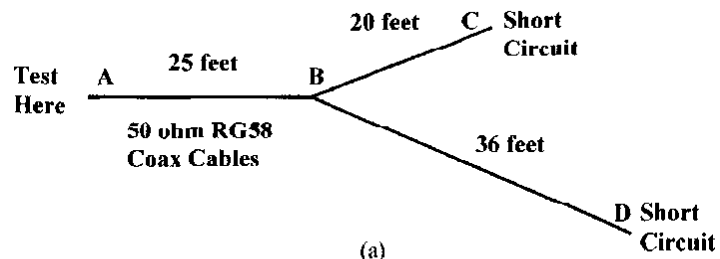

Fig. 3 (a) Network topology, (b) Reflectometry test signals of network shown (a) with TDR, FDR (MSR7 SWR), STDR, SSTDR [1, 2, 3].

creates a measurement problem for the TDR, as any noise (which may be as large as or larger than the TDR signal) will corrupt the TDR trace. TDR is therefore not optimal for testing wires that are live.

TDR may be used for testing wires with multiple branches. The limitation of this (and all) reflectometry methods is that the junctions and ends of the branched network all result in reflections and multiple reflections that show up in the reflectometry trace, but it is difficult to extract the network topology from the reflectometry trace.

### 2.3. Frequency domain reflectometry (FDR)

Frequency domain reflectometry (FDR) sends a set of stepped-frequency sine waves down the wire. There are three types of frequency domain reflectometry that are commonly used in radar applications that are distinct in that they each measure a different sine wave property (frequency, magnitude, phase) in order to determine distance. Related methods are also found in wire testing. These are Frequency Modulated Continuous Wave (FMCW) systems (which measure frequency shift), Phase Detection Frequency Domain Reflectometry (PD-FDR) systems (which measure phase shift), and Standing Wave Reflectometry (SWR) systems (which measure amplitude or nulls of the standing wave).

#### 2.3.1 Frequency modulated carrier wave (FMCW)

FMCW systems vary the frequency of the sine wave very quickly, generally in a ramp function, and measure the frequency shift between incident and reflected signals, which can be converted to time delay knowing the speed at which the frequency is stepped. This has not been implemented for wire testing, because of limitations on speed at which the frequency can be swept and the accuracy at which the frequency shift can be measured [8].

#### 2.3.2. Phase detection frequency domain reflectometry (PD-FDR)

Phase Detection Frequency Domain reflectometry (PD-FDR) measures the phase shift between incident and reflected waves. A voltage controlled oscillator (VCO) provides the sinusoidal signal that is stepped over a given bandwidth ( $f_{min}$ - $f_{max}$ ) with a frequency step size  $\Delta f$ . Reduced by a -10 dB sample of the incident sine wave is sent to the mixer, and the remainder is sent to the cable. The incident signal travels down the cable and reflects back from the load. The reflected wave is isolated from the incident wave by the second directional coupler and is sent to the mixer. The mixer "multiplies" the two sine waves, which gives signals at the sum and difference of their two frequencies. When they are at the same frequencies as they are in FDR, this difference is at zero frequency (DC). This DC voltage at the mixer output is the signal that the computer will detect and use to determine the length and load on the line. An analog-to-digital (A/D) converter used to read the mixer output effectively acts as a low-pass filter and removes the higher frequency components.

The number of periods ("frequency") of the DC voltages collected over the injected frequency band is linearly dependent on the wire length. The Fast Fourier transform (FFT) of this collected waveform will give a Dirac delta function (single spike) at a location we will call *Peak*. The location of *Peak* in the FFT response is proportional to the length of the wire. The length is found from this peak index by:

$$L = 2L_{max} \left( \frac{Peak - Peak(0)}{N_{FFT} - 1} \right) = \frac{1}{2} \left( \frac{Peak - Peak(0)}{N_{FFT} - 1} \right) \left( \frac{N_F - 1}{f_2 - f_1} \right) V_p \quad (1)$$

where *Peak* — location of the Dirac delta peak in the FFT (an integer value), Peak index for corresponding length in FFT;

$V_p$  - velocity of propagation in the cable (m/s);

$f_1$  - start frequency of the FDR (Hz);

$f_2$  - stop frequency of the FDR (Hz);

$N_{FFT}$  - number of frequencies in the FDR =  $\text{integer} \left[ \frac{(f_2 - f_1)}{\Delta f} \right]$ ;

$\Delta f$  - frequency step size for FDR (Hz)

$L_{max}$  - maximum length shown below

$N_{FFT}$  - number of points in the FFT (an integer value, generally 1024, 2048, 4096 or 8192)

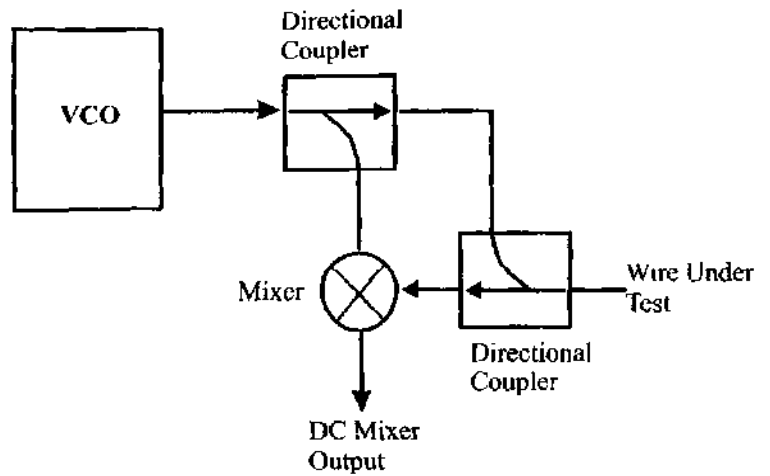

Fig. 4 PDFDR block diagram

The resolution (accuracy) of the measurements ( $\Delta L$ ) is given by [4]:

$$\Delta L = \frac{v_p}{(2N_{FFT}\Delta f)} \quad (3)$$

The maximum length ( $L_{\max}$ ) that can be measured on an ideal wire is limited by the frequency step size and the Nyquist criterion:

$$L_{\max} = \frac{v_p}{4\Delta f} \quad (4)$$

This DC value is the same as for the PD-FDR, such as shown in Fig. 5. The mixer output goes into a digital to analog converter, which automatically filters out the high frequency component. The DC values as a function of frequency are a sinusoidal wave whose frequency is linearly proportional to the wire length, virtually identical to the FDR responses shown in Fig. 5. The MSR is more accurate than the SWR for small reflections, however this advantage has not been found to have practical application, as it still cannot analyze the very small anomalies associated with frays or chafes. MSR is less expensive and smaller than PD-FDR, since it does not require the directional couplers. For branched networks, the MSR response includes the multiple reflections plus their sums and differences, which makes its response more complex to calculate than the PD-FDR branched network response. Limitations on the use of MSR for live wires and short length wires are virtually identical to those for PD-FDR.

The MSR system is less expensive than either the PD-FDR or SWR. It requires only a voltage controlled oscillator (VCO), mixer, and related control circuitry. It is feasible to integrate this system into a single chip and imbed it directly into the wiring system.

#### 2.4. STDR/SSTDR

Block diagrams of Sequence Time Domain Reflectometry (STDR) (Furse, Smith, Safavi and Lo 2005) and Spread Spectrum Time Domain Reflectometry (SSTDR) are shown in Fig. 7 (Furse, *et al* 2005, Smith 2003). STDR uses a pseudo noise (PN) code as the test signal, as shown in Fig. 8a (Furse, *et al.* 2005, Smith 2003). The PN signal can be very, very small compared with the aircraft signal on the wire (-20 dB down, for instance) and is well below the allowable noise floor of the aircraft signal shown in Figs. 8a and 8b (Furse, *et al.* 2005, Smith 2003). Although the PN code magnitude is small, it is relatively long (1023 bits, for example) and has a distinct and recognizable pattern. The correlation responses of STDR and SSTDR are shown in Figs. 8(c) and 8(d) (Furse, *et al.* 2005, Smith 2003).

The S/SSTDR is capable of being miniaturized into a mixed signal IC, which will make it very small and likely the least expensive reflectometry system available. It is very feasible to consider imbedding this system in the wiring system. S/SSTDR is capable of analyzing branched networks, with the same limitations as FDR and TDR, that the network topology must be extracted from the multiple peaks in the reflection data.

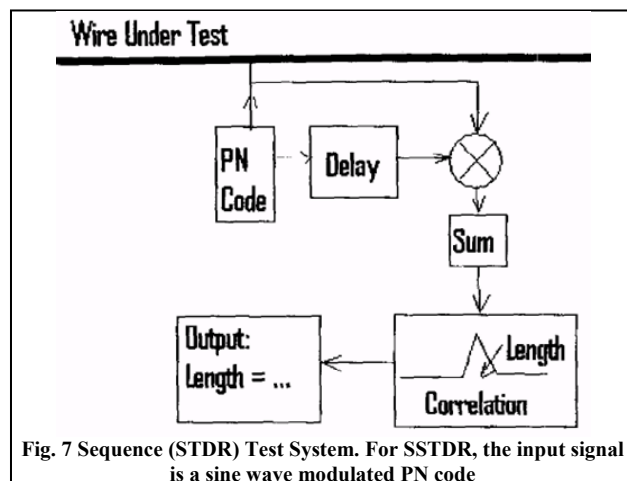

#### 3.1. Conclusions

As a result, TDR is a most hardest in hardware realization. TDR require high quality pulse generator, high speed AD convertor for measuring of wear signals. Problems of connections between measuring device and wire leads to mismatch between result for the same wire and cables.

On other hand we have FDR methods. Measuring device based on FDR technology can be produced with use of less comprehensive electronics, so it can be done with several low-frequencies IC. For FDR, removing the expected incident pulse using signal processing and increasing the resolution of the Fourier transform used to analyze the FDR data reduce the minimum measurable length. For all of the reflectometry systems, it is possible to tell that there is a reflection within the minimum length, which is generally on the order of 2 feet, but not to determine accurately within this distance where the fault occurs.

The biggest problems of FDR are:

- 1) Result of FDR can be received as a result of FFT proceeding of some data from measuring process.
- 2) All existing FDR methods do not allow eliminating "blind spots" at all. To eliminate "blind spots" FDR still require additional physical wire before wire to test.
- 3) FDR methods based on measuring of so-called standing waves. But there is no answer how to use those standing waves (their frequencies, magnitudes and phases) in complex.

The answer based on understanding of reasons why we receive all those standing waves. And at the same time we need to proceed not signal envelope but signal states in predefined times.

An important ability of the reflectometry systems is the ability to run on live systems to detect intermittent

faults. For FDR is possible to use predefined range of waves to test. For TDR this can be done only with filter.

Frequency domain reflectometry systems are limited to low frequency circuits, as they would interfere with the higher frequency lines. Even for the low frequency circuits, their signal to noise ratio is not as good as the STDR. The same holds true for TDR. S/SSTDR systems are therefore the best for locating intermittent faults or for real time testing of live circuits.

Another important aspect of reflectometry systems for which solutions are just beginning to emerge is analysis of branched networks, since many of the power distribution systems that are of prime importance to test are extensively branched.

All of the reflectometry systems have the potential to locate faults on branched networks, since individual peaks or steps will be seen in their response for each reflection point. Reflectometry responses from branched networks are often too complex to interpret by hand.

Some aspects of networks will always be impossible to resolve with a single point measurement. For instance, when one of two identical arms breaks, it will be possible to tell how far away the break is, but it will not be possible to tell which arm is broken. When an open and short circuit occur at the same distance from the test system, the reflections cancel each other out and appear completely invisible. In cases such as these, multiple test points on the same system will be needed, which will in turn require the coordination and communication of data for analysis.

Smart imbedded test systems for wiring hold the promise of revolutionizing the way large wiring systems are designed and maintained. The ability to precisely identify and locate wiring faults remotely enables monitoring, diagnosis, control, and potentially even prognosis of degrading systems. Critical elements including sensors that are small enough to be imbedded, that are capable of locating faults on live systems, and that can be used on branched networks are all rapidly emerging and are showing excellent results.

Not all network analysis can be completed from a single test point, which means that multiple sensors need to communicate and work together. The complexity of today's wiring systems means that there could be potentially thousands of distributed sensors in the highly lossy, highly multipath communication environment of a building or plane. Communication can be efficiently done on the wires being tested, in some cases potentially with the same sensors that are used to test the wires, but if the wire breaks, then critical information would be lost.

### References

1. Waddoups, Brent (2001), "Analysis of reflectometry for detection of aircraft wiring insulation", MS Thesis, Utah State University, Logan, Utah, (all theses and dissertations in this paper can be obtained from: [www.lib.umi.com](http://www.lib.umi.com)).
2. Schmidt, Mark (2002), "Use of TDR for cable testing", MS Thesis, Utah State University, Logan, Utah.
3. Jani, Alok (2003), "Location of small frays using TDR," MS Thesis, Utah State University, Logan, Utah, 2003.
4. Furse, Cynthia, Chung, You Chung, Dangol, Raksh, Nielsen, Marc, Mabey, Glen, Woodward, Raymond, (2003), "Frequency domain reflectometry for on board testing of aging aircraft wiring", IEEE Trans. Electromagnetic Compatibility, 306-315, May.
5. Chung, You Chung, Furse, Cynthia, Pruitt, Jeremy, (2005) "Application of phase detection frequency domain reflectometry for locating faults in an F-18 flight control harness", IEEE Trans. Electromagnetic Compatibility, 47(2), 127-114.
6. Tsai, P., Lo, C., Chung, Y. C. and Furse, C. M. (2005), "Mixed signal reflectometer for location of faults on aging wiring", IEEE Sensor Journal, 5(6), 1479-1482.
7. Furse, C., Smith, P., Safavi, M. and Lo, C. (2005), "Feasibility of spread spectrum sensors for location of Arcs on live wires", IEEE Sensors J., 5(6), 1445-1450.
8. Furse, C. and Kamdar, N. (2002), "An inexpensive distance measuring system for navigation of robotic vehicle", Microwave and Optical Tech. Letters, 33(2). 84-97, April.
9. Horiashchenko Kostyantyn. Analysis of spectral components for phase method with multiplies frequencies for use in communication lines. Message 2. Khmelnytskyi. Measuring and Computing Devices in Technological Processes. 2013. Issue 4. Pp. 58-62
10. Horiashchenko Kostyantyn. Spectral components definition of the signal with harmonic signal noninteger period components. Khmelnytsky National University, Khmelnytsky, Ukraine. 2014. Issue 1. P. 195-198

Рецензія/Peer review : 23.5.2017 р.

Надрукована/Printed : 7.7.2017 р.

Стаття рецензована редакційною колегією