

МЕТРОЛОГІЯ, СТАНДАРТИЗАЦІЯ, СЕРТИФІКАЦІЯ ТА ВИМІРЮВАЛЬНА ТЕХНІКА В ТЕХНОЛОГІЧНИХ ПРОЦЕСАХ

UDC 614.88: 621.3

DOI: 10.31891/2219-9365-2020-65-1-1

¹OLEKSIY YANENKO ²ANDRIY TKACHUK ²ROMAN TKACHUK

¹National technical university of Ukraine «Kyiv polytechnic institute»,

²Ternopil Ivan Pul'uj National Technical University, Ternopil, Ukraine

AUTOMATED TESTING SYSTEM FOR IMPLANTS TO REGULATE INTRAOCULAR PRESSURE

Purpose of work. The implantation of drainage devices in glaucoma is usually performed after previous unsuccessful treatments and is the patient's last chance to save his vision. The article describes the device that allows automating the process of preoperative check-up of implants of different types used for intraocular fluid withdrawal in case of glaucoma. This device will help to increase the success of the operation and help to preserve the vision of the patients with glaucoma due to the pre-test of the implants for serviceability and parameters of intraocular fluid withdrawal.

Methodology. For the realization of the goal, the authors developed a functional scheme of the automated system for measuring and controlling the parameters of the intraocular pressure regulation implants based on the microsystem technology elements.

The results. Depending on the material and hardness of the implant, there are three possible cases in which the implant opens earlier and there is a risk of hypotension to the patient's eye, later there is a risk of hypertension and the implant works in the normal pressure zone. The authors provide testing graphs of three implants of varying levels of hardness, as well as a graph of the reproducibility of the characteristics of the non-faulty implant.

Scientific innovation. The method of testing implant parameters by way of hardware overpressure creation with the possibility of automated control parameters of preoperative testing the implants is proposed.

Practical significance. The developed automated system for preoperative testing of implants, which provides:

- simplification of the scheme with the simultaneous possibility of automating the process of preoperative testing of implants of different types;
- allows getting an increase of sensitivity, measurement accuracy, and objectivity of implant parameters determination;
- determination of their suitability for use in the medical-surgical practice by the parameters of fluid withdrawal, exactly opening pressure, closing pressure and reproducibility of the characteristics during the repeated operation, which will contribute to the efficiency of the performed operations;
- reducing the time of implant check, which is limited by 2-3 minutes, and the possibility to save information about the parameters both in electronic (computer) and paper form.

Key words: glaucoma, intraocular pressure, implant, pressure measurements, testing, process automation, microsystems engineering.

¹ОЛЕКСІЙ ЯНЕНКО ²АНДРІЙ ТКАЧУК ²РОМАН ТКАЧУК

¹Національний технічний університет України «Київський політехнічний інститут»,

²Тернопільський національний технічний університет імені Івана Пулюя, Тернопіль, Україна

АВТОМАТИЗОВАНА СИСТЕМА ТЕСТУВАННЯ ІМПЛАНТАТІВ ДЛЯ РЕГУЛЮВАННЯ ВНУТРИШНЬОГО ТИСКУ

Імплантація дренажних пристроїв при глаукомі зазвичай проводиться після попередніх невдалих процедур і є останнім шансом пацієнта врятувати зір. У статті описано пристрій, що дозволяє автоматизувати процес передопераційної перевірки імплантатів різного типу, що використовуються для відведення внутрішньоочної рідини у разі глаукоми. Цей пристрій допоможе підвищити успіх операції та допоможе зберегти зір пацієнтів з глаукомою завдяки попередньому тестуванню імплантатів на справність та параметри виведення внутрішньоочної рідини.

Для реалізації поставленої мети автори розробили функціональну схему автоматизованої системи вимірювання та контролю параметрів імплантатів регуляції внутрішньоочного тиску на основі елементів мікросистемної технології.

Залежно від матеріалу та твердості імплантанта, можливі три випадки, коли імплантат відкривається раніше і існує ризик гіпотонії в оці пацієнта, пізніше існує ризик гіпертонії, і імплантат працює в зоні нормального тиску. Автори наводять графіки тестування трьох імплантатів різного рівня твердості, а також графік відтворюваності характеристик несправного імплантату.

Запропоновано метод тестування параметрів імплантатів шляхом апаратного створення надлишкового тиску з можливістю автоматизованого контролю параметрів передопераційного тестування імплантатів.

Розроблена автоматизована система для передопераційного тестування імплантатів, яка забезпечує:

- спрощення схеми з одночасною можливістю автоматизації процесу передопераційного тестування імплантатів різних типів;
- отримання підвищення чутливості, точності вимірювання та об'єктивності визначення параметрів імплантату;

– визначення їх придатності для використання в лікувально-хірургічній практиці за параметрами відбору рідини, точно тиску відкриття, тиску закриття та відтворюваності характеристик під час повторної операції, що сприятиме ефективності виконуваних операцій;

– скорочення часу перевірки імплантату, який обмежений 2–3 хвилинами, та можливість збереження інформації про параметри як в електронному (комп'ютерному), так і в паперовому вигляді.

Ключові слова: глаукома, внутрішньоочний тиск, імплантат, вимірювання тиску, тестування, автоматизація процесів, інженерія мікросистем.

Introduction. Glaucoma is one of the most severe diseases in ophthalmology and often leads to loss of vision and is the second most frequently occurring disease [1]. The main cause of glaucoma is uncontrolled changes in the passage of intraocular fluid through the trabecular network; in the case of pathology, this leads to an increase in intraocular pressure (IOP) and eye nerve damage. During this disease, an important means of preserving the patient's vision is to control IOPs to take timely IOP normalization measures. Such control can be performed on an outpatient basis (one-time) or using an implanted microchip, e.g., 1.2–2.4 mm in size with regular IOP information transmission at 914 MHz or 2.2 GHz [2,3]. However, it should be noted that the use of the microchip is currently in the process of experimental research approbation and is not widespread.

The last, most effective method of IOP normalization is the implantation of drainage devices (valves), which is usually performed after previous unsuccessful treatments and is the patient's last chance to save his vision. Installation of the valve is carried out in the process of a complex surgical operation.

Molteno (Molteno Ophthalmic Ltd, New Zealand), Baerveldt (Advanced Medical Optics, USA), Ahmed (New World Medical Inc, USA), and Krupin (Hood Laboratories, USA) valves are used as implants [4]. Timely actuation of the valve and pressure reduction ensures the storage of the optic nerve in working condition.

However, some parameters of the implants may have considerable variation, it is also important to maintain their stability overtime during the usage of the product [5]. The normal range of intraocular pressure at which no pathological lesions occur and to which the implant should react is within the range of 9–21 mm Hg, but it can fluctuate, even up to 60 mm Hg. [6].

Therefore, testing existing implants before surgery is an actual task for ophthalmologists and implant designers. Evaluation of implant parameters before implantation is one of the components of successful surgical intervention and preservation of the patient's vision [7]. The testing procedure consists of measuring the pressure parameters at which the intraocular fluid is output by the implant before insertion into the human eye. It improves the selection and helps to identify deviations in the parameters of the intraocular fluid output in the implant and make predictions about its further performance when used.

Literature review. Modern methods and tools for implant operability testing provide for hardware creation of overpressure of physiological solution and its passing through the controlled valve with the use of analog or digital control device, which can significantly differ in structural construction, accuracy and resolution of pressure parameters determination. Equally, important are not only metrological parameters but also the simplicity and availability of such equipment for a preoperative check before implantation.

Currently, there are several well-known methods of testing implants for workability and measuring equipment built on their principles. Currently, there are several well-known methods of testing implants for workability and measuring equipment built on their principles.

Thus, for example, in [8] is considered testing of implants without a pressure sensor, instead of it an operator manually lifts a reservoir with a saline solution to a given programmed height. The disadvantages of this technical solution include the inaccuracy and subjectivity of the reference when setting the pressure, as well as the lack of automation.

In work [9] the device of preoperative testing has in its composition a tank with a physiological salt solution, 3-inlet splitter, analog manometer, cannula 30G (external diameter 0.3112 mm and internal diameter 0.159mm), connecting tubes, and the tank with a physiological salt solution is connected to the input of 3 inputs of the splitter, the first output of which is connected to the manometer, and the second output is connected through the cannula with the valve input. By raising or lowering the physiological salt solution tank, the ground gravity increases the pressure in the system to pass the solution through the AGV valve and fixes the pressure values of its actuation. The disadvantages of this device are the significant inaccuracy and subjectivity of the pressure reading and the assessment of the valve functionality for implantation.

The paper [10] describes two methods of preoperative testing of drainage valves, presented in the form of two protocols.

One of them realizes the influence of a change of world gravitation, and in the other overpressure is created by the engine connected to the tank with saline which exit through a connecting tube and 3-inlet splitter is connected to a pressure balancing tube, the manometer, and AGV. Insufficient sensitivity and complexity of registration of the moment of operation of the valve which depends on the professionalism of the operator, and accordingly some subjectivity in definition of implants parameters, reduces the efficiency of the definition of their suitability for use should be attributed to lacks of the considered device.

A more complicated verification system is described in [11], the excess pressure in it is created by a reservoir with saline solution in the form of an infusion pump. The created pressure is controlled by an analog manometer and at the inlet of the AGV valve - by a digital sensor. Besides, the system is also equipped with a high-speed digital camera with a microscope, used to record the flow of solution through the implant.

The disadvantage of the described device and method of verification is the significant cost and complexity due to the use of infusion pump, video camera, and microscope, which are necessary to record the time and parameters of the valve actuation, as well as the focus on the detection of fluid passage only with the implant type AGV, which limits their mass use.

Shortcomings of previous devices have been corrected in the device [12]. The system is based on a microcontroller, a stepper motor with a worm gear, a tank with saline, a microelectromechanical pressure gauge, a liquid detector, and an ADC connected accordingly.

The system provides a significant increase in the sensitivity and accuracy of implant parameters determination. At the same time, the weak point of this technical solution is the use of mechanical elements, such as a stepper motor with worm gear and a piston in a reservoir with saline. The presence of these elements limits the use of such a system more in stationary conditions at implant manufacturing enterprises or specialized ophthalmological treatment centers. However, the development of ophthalmological care and the availability of many centers requires the creation of highly accurate but affordable devices for preoperative verification and testing of such implants in clinics and outpatient clinics. Also, the testing process should be more natural and closer to the physiological processes of intraocular pressure changes.

Purpose. Based on the above-mentioned device the authors set a task to develop a simple and reliable measurement scheme. Preserving the sensitivity, accuracy, and objectivity of implant parameters determination as well as their effectiveness by determining their suitability for use in medical-surgical practice.

Methods. Fig.1 shows the authors' proposed functional scheme of the implant testing system for the regulation of intraocular pressure.

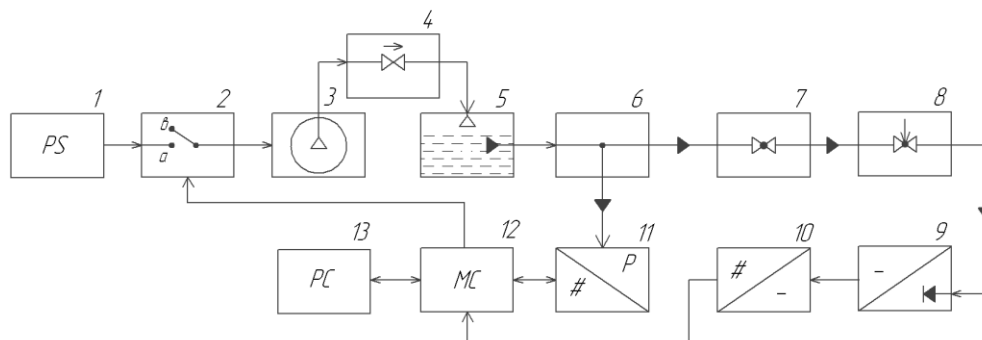

Fig. 1. Functional scheme of the implant testing system for the regulation of intraocular pressure

The system includes a power supply unit (accumulator) 1, electronic key 2, miniature compressor 3 is connected through the passage valve 4 with a reservoir with saline solution 5, 3-input splitter 6, with an electro-mechanical pressure gauge 11 with a shut-off valve of saline solution 7, and a canula with the implant 8. To the output of the implant is connected liquid detector 9 and ADC 10, which is connected to the microcontroller input 12. The first output is connected to computer input 13, and the second output is connected to electronic key control input 2.

The implant testing device for intraocular pressure regulation works as follows. First, the implant is connected to the cannula, which is connected to the stopping tap of the saline solution supply 7. The computer 13 switches on the implant testing mode, microcontroller 12 switches on the compressor 3 via the electronic key 2 to increase the pressure in the reservoir 5, due to the throughput valve 4 the air cannot return to the compressor from the reservoir. The pressure in the connection system gradually increases and is constantly monitored by a microelectromechanical pressure sensor 11, the level of pressure is constantly read by microcontroller 12 and recorded in the computer memory as a pressure graph. The system pressure rises from zero to the trigger value of the implant being tested.

When the implant is activated, the liquid appears on the implant outlet, which falls on the liquid detector 9, the opening pressure level of the implant is fixed. The signal of the detector 9 is converted into digital form via ADC 10 and is sent to the microcontroller 11, which stops the compressor 3 turning off the power supply due to its electronic key 2. The value of opening pressure from microcontroller 11 is fixed on the computer.

When the valve is opened, the pressure in the system gradually decreases, the dynamics of pressure change is constantly monitored by the microelectromechanical pressure gauge 11 and input into the computer 13. When the valve is closed, the pressure is set to a constant level, the value of closing pressure from the electromechanical pressure gauge 6 is transmitted to microcontroller 11 and input into the computer 13. With the use of the computer

program is drawn up a graph of the change of pressure of this instance of the valve and determined the working range of pressure in which the valve can operate:

$$P_3 = P_2 - P_1, \tag{1}$$

where P_1, P_2 – is the value of the opening and closing pressure of the valve.

Also, the system provides the ability to check the reproducibility of the received valve parameters, for which after the first step information is taken, multiple test cycles are activated, the average value of the dynamic range is determined, for example, for $n_{(3)}$ measurements:

$$\Sigma P_n = (P_{n1} + P_{n2} + P_{n3}) / n, \tag{2}$$

Where P_{n1}, P_{n2}, P_{n3} – pressure variation ranges for repeated 3-times measurements as well as the scattering percentage of each measurement.

The obtained values are compared with the standard ones (9–21 mm Hg), the results are summed up according to the implant conformity or non-conformity with the established norms and the testing protocol is filled in.

Fig. 2 shows the testing algorithm, which contains the steps for starting and working on the implant checking system.

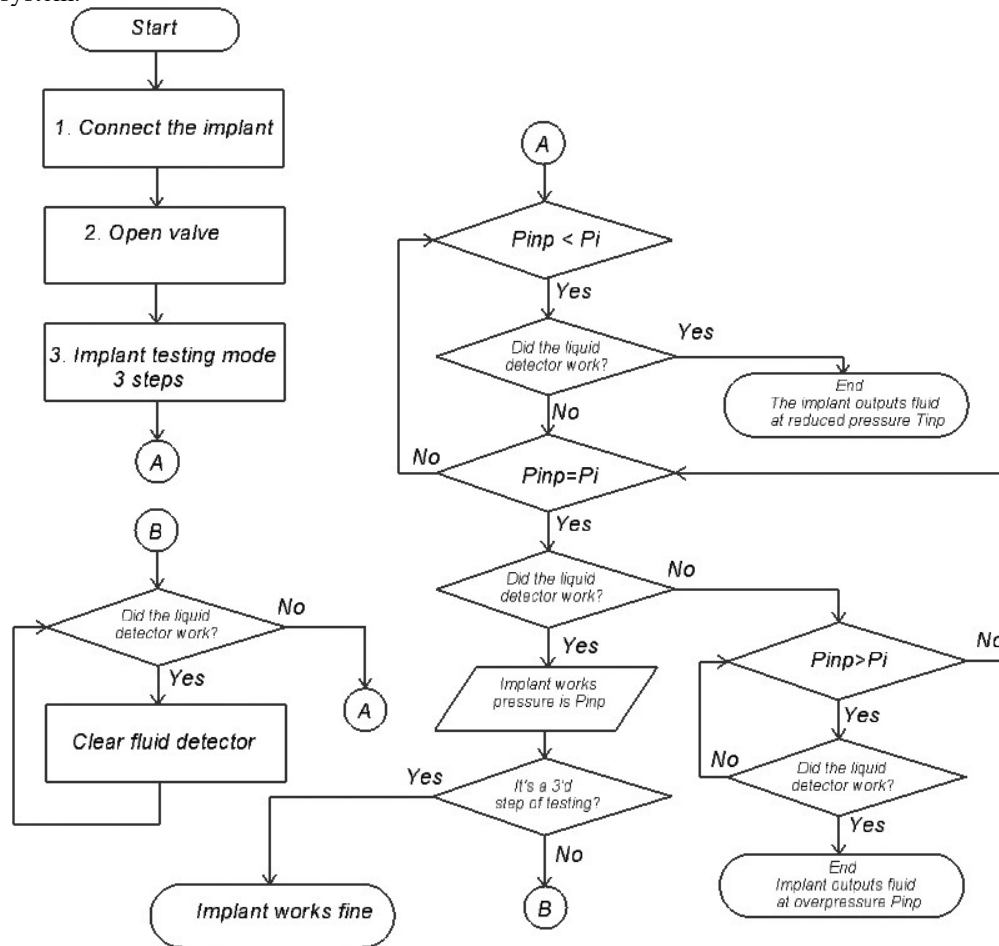

Fig. 2. Algorithm of the implant testing system for the regulation of intraocular pressure

In the first step, the operator will connect the cannula with the implant to the crane. In the second stage, the operator will open the tap. The third step starts testing the implant for which the microcontroller controls the electronic key with a compressor and increases the fluid pressure that comes to the implant inlet, feedback is provided by a microelectromechanical pressure sensor that continuously records the pressure level at 50 Hz and transmits data to the microcontroller, the second feedback is provided by the fluid detector, registers the passage of fluid through the implant.

The pressure in the above system constantly increases until the implant starts to withdraw the fluid, which is recorded by the fluid sensor. At the moment the fluid passes through the implant, the system determines the pressure level at which the implant starts to remove the test fluid, after the operation of the fluid detector, the system registers the pressure of the opening of the implant and stops the fluid supply point (1a, 1b, 1c) in Figure 2.

Open valves smoothly reduce the pressure level in the system until it is completely closed (points 2a, 2b, 2c). In the process of testing the valves depending on the quality of these products, different levels of hardness and the like etc.

Results. During the testing process, the parameters and conditions that are important for further ensuring the quality of the implants are checked and there are three options for the obtained result. Fig. 3 shows the graphs of checking the pressure parameters for three implants of different hardness levels, marked by the symbols a, b, and c.

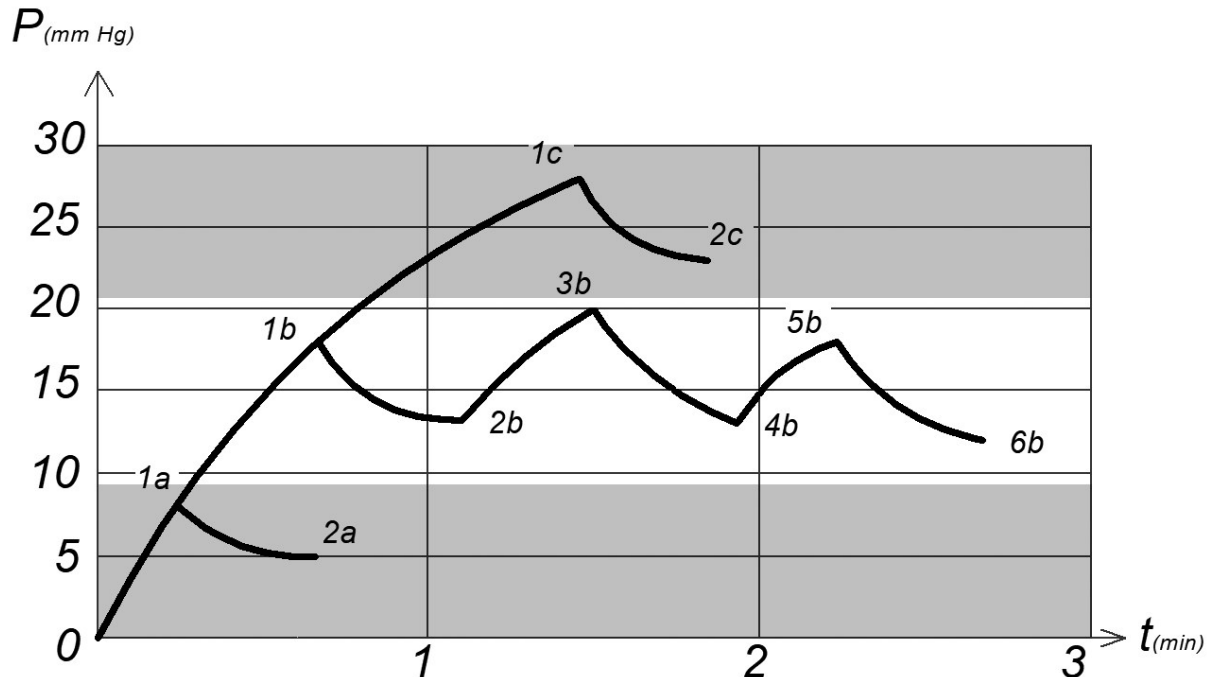

**Fig. 3. Test pressure diagram of implants of different valve hardness:
 a, c – defective implants, b – functional implant**

Fig. 3 Test pressure diagram of implants of different valve hardness. a, c – defective implants, b – functional implant. First implant a (Fig. 3) has a reduced level of hardness and is characterized by pressure changes from 8 mm Hg. (valve opening point 1a) to 5 mm Hg. (Closing point 2a). The testing cycle of such an implant lasts within 30–40 seconds. Activation of the liquid detector at this stage is a sign of the implant failure with the risk of hypotension for the patient's eyes and such a valve is not suitable for use.

The second implant, marked with the symbol b, has a higher hardness and therefore opens at a higher pressure level, also increases the test time to 65 seconds. The change of the pressure parameters of the second implant (Fig. 3) of the points 1b and 2b is within the normal range of 18–13 mm Hg. Activation of the fluid sensor indicates that the implant works within the normalized intraocular pressure range of 9–21 mm Hg. After determining the implant, which meets the normative requirements, the reproducibility of parameters is checked by the method of multiple repeated pressure increase. For this purpose, the operator removes the fluid from the indicator plate of the fluid detector and switches on the system of pressure increase again up to the moment of the fluid detector actuation, fixes the moment of the implant reopening in the point 3b. The signal from the detector stops the compressor, after which the open valve pressure is reduced and stabilized at point 4b. This step is then repeated (points 5b and 6b). In the case of repeatability, the valve is recognized as a quality valve due to triple testing and used for surgical treatment of a patient with glaucoma.

The third implant c (Fig. 3) is characterized by high hardness (stiffness) and change of actuation pressure within the range of 28–23 mm Hg at the points 1c and 2c, which exceeds the normal range of intraocular pressure. Activation of the liquid detector at this pressure indicates a complete malfunction of the implant. The use of such an implant indicates the risk of hypertension in the patient's eye. Реалізація автоматизованої системи для проведення тестування наявних імплантатів перед операційним хірургічним втручанням проведена з використання наступних елементів мікросистемної техніки.

Microcompressor WHALEB-100 with 1.5 V supply voltage was used to create the required pressure variation range from 0 to 30–40 mm Hg. To provide automated modes of system operation, the STM32F103RET6

chip was used as a microcontroller. An important element of the system is a pressure sensor – it is one of the functional units, which provides the possibility of automation of the verification process and the corresponding accuracy of implant testing. The ST Microelectronics LPS33HW microelectromechanical pressure sensor satisfies these requirements. The sensor has an integrated filter, a pressure reading frequency from 1 to 75 Hz, the microcontroller reads the data from the sensor via the SPI interface, and provides communication with a computer. The accuracy of the pressure measurement is 0.075 mmHg or 0.25 % at the maximum pressure in the LPS33HW. WAVEGAT MH RD resistive liquid detector with 4 cm × 5 cm sensor part size, with ADC based on LM393 comparator, 5V supply voltage, and comparator response speed of 1.3 μs was used as a liquid detector. The conversion characteristic for the analog output of such a detector is a discrete function of the presence of liquid on the sensor plate of the detector w and looks:

$$\begin{cases} y = 0, & \text{at } w = 0 \\ y = 1, & \text{at } w \neq 0 \end{cases} \quad (3)$$

As follows from (3) on the digital output 0 or 1 is formed, in the absence or presence of liquid on the sensor, the required response sensitivity is adjusted by changing the resistance of the potentiometer.

Conclusions. The proposed system provides:

1. Simplification of the scheme with the possibility to automate the process of preoperative verification of implants of different types.
2. Allows getting higher sensitivity, measurement accuracy, and objectivity of implant parameters determination.
- 3 Determining their suitability for use in medical-surgical practice by the parameters of fluid withdrawal, namely opening pressure, closing pressure, and reproducibility of the characteristics at repeated operation, which will contribute to the efficiency of the performed operations
4. Shortened implant testing time, which is limited to 2-3 minutes, and the ability to save and store parameter information, both electronically and in paper form.

The system developed by the authors is a promising one and can be used not only for checking known types of valves but also for testing implanted radio-frequency chips [2,3], which are currently only undergoing experimental testing.

Reference

1. Kingman, Sharon. Glaucoma is second leading cause of blindness globally. *Bulletin of the World Health Organization*, 82 (11), 887 - 888.
2. A. Agarwal, A. Shapero, D. Rodger, M. Humayun, Y. Tai and A. Emami, "A wireless, low-drift, implantable intraocular pressure sensor with parylene-on-oil encapsulation," 2018 IEEE Custom Integrated Circuits Conference (CICC), San Diego, CA, 2018, pp. 1-4. doi: 10.1109/CICC.2018.8357049
3. H. Bhamra, J. Tsai, Y. Huang, Q. Yuan, J. V. Shah and P. Irazoqui, "A Subcubic Millimeter Wireless Implantable Intraocular Pressure Monitor Microsystem," in *IEEE Transactions on Biomedical Circuits and Systems*, vol. 11, no. 6, pp. 1204-1215, Dec. 2017. doi: 10.1109/TBCAS.2017.2755596
4. *Glaucoma Surgery: Treatment and Techniques* / Luigi Caretti, Lucio Buratto and others USA: Springer International Publishing, 2018. – 133 p.
5. Ткачук А. Недоліки дренажних пристроїв для виведення внутрішньоочної рідини при глаукомі / Ткачук Р. А., Ткачук А. А., // *Матеріали IV Міжнародної науково-технічної конференції „Теоретичні та прикладні аспекти радіотехніки, приладобудування і комп’ютерних технологій“ присвячена 80-ти річчю з дня народження професора Я.І. Проця, 20-21 червня 2019 р.* – Т. : ФОП Паляниця В. А., 2019. — С. 146–148. — (Біомедична Інженерія).
6. *The Glaucoma Book* / Paul N. Schacknow, John R. Samples – USA: Springer, 2010. – 1043 p.
7. Francis, B. (1998). Characteristics of glaucoma drainage implants during dynamic and steady-state flow conditions. *Ophthalmology*, 105(9), 1708–1714. doi: 10.1016/S0161-6420(98)99042-X
8. Patent US № 05656026, A61 1/00, 12.08. 1997 “Method of in vitro testing one-way pressure gradient limiting valved glaucoma drainage implants”
9. Cheng, J., Beltran-Agullo, L., Buys, Y. M., Moss, E. B., Gonzalez, J., & Trope, G. E. (2016). Flow Test to Predict Early Hypotony and Hypertensive Phase After Ahmed Glaucoma Valve (AGV) Surgical Implantation. *Journal of Glaucoma*, 25(6), 493–496. doi:10.1097/jg.0000000000000318
10. Porter, J. M., Krawczyk, C. H., & Carey, R. F. (1997). In Vitro Flow Testing of Glaucoma Drainage Devices. *Ophthalmology*, 104(10), 1701–1707. doi:10.1016/s0161-6420(97)30077-3
11. Choudhari, N. S., Badakere, S. V., Richhariya, A., Chittajallu, S. N. S. H., Senthil, S., & Garudadi, C. S. (2018). Is Ahmed Glaucoma Valve Consistent in Performance? *Translational Vision Science & Technology*, 7(3), 19. doi:10.1167/tvst.7.3.19
12. Andriy Tkachuk "Automated implant testing system for intraocular pressure adjustment," / Andriy Tkachuk, Roman Tkachuk, Oleksiy Yanenko and Konstantin Shevchenko, 2020 15th International Conference on Advanced Trends in Radioelectronics, Telecommunications and Computer Engineering (TCSET), Slavske, 2020.

Надійшла / Paper received: 19.03.2020

Надрукована / Paper Printed : 05.06.2020