

623.4.084.7

1, 1, 2  
1  
2

[2],  
« », « »;  
« »; - « », AAWS/M "Javelin"  
SRAW "Predator" )

1944  
"Rotkaphchen" ("")  
1944 . 100  
1945 . -7.  
- 47 "Dragon-2", - "Eryx",  
- "MILAN 3" )  
- », " - ";  
- "TRIGAT",  
« », « », « », « » ).

[2],  
" -1", 1947-1948 .  
6" ". ( ),  
( ) " ).  
( ) ( )

MLRS/TGW (Multiple Launch Rocket System/Terminally Guided Warhead),

MLRS,  
 1984  
 " ( ), " " ( ), " - CSF"  
 ( ) " - EMI" ( );  
 (Brilliant Anti-Tank),

[2, 3, 4, 5].

"  
 " " " " ;  
 SADARM,  
 (  $\Omega$  ).  
 109 5  
 198  
 ATACMS,  
 GBU-15  
 AGM-130  
 MLRS,  
 "Aerojet" "Alliant  
 Techsystems";  
 155-  
 BONUS

( .1) , ( .2),  
 ( .3) [2, 3, 4, 5].

"Bofors Defence" ( )

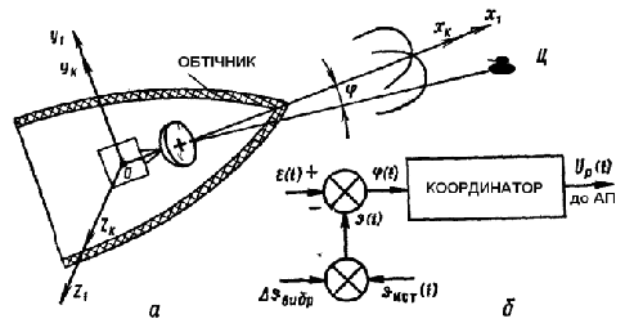

. 1. ( )

( )  
 [1, 2, 3, 4, 5, 6, 7].  
 [2, 3, 4]

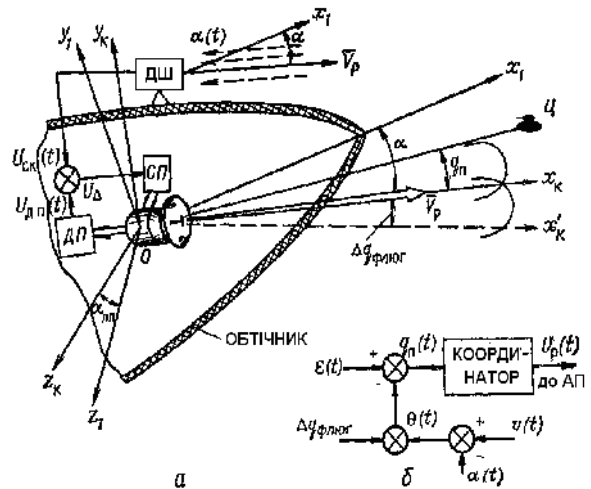

. 2. ( )

( ) [2, 3].

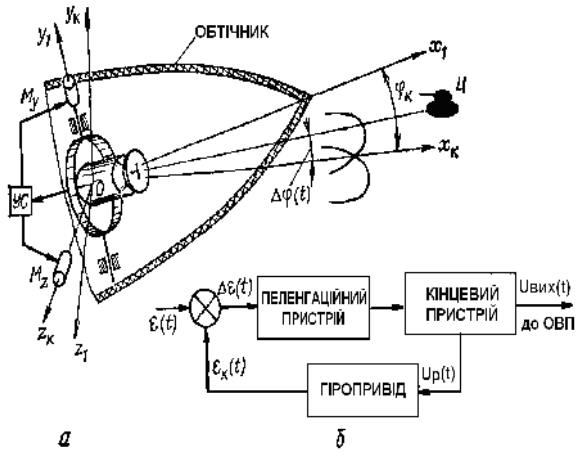

а  
б  
3.

[2, 3, 4, 5, 6]

$$D \geq \sqrt{[d_{СТР\ MAX} + V t_{\Sigma}]^2 + H^2}$$

d —  
( );  
V — ;  
t —

$$\vartheta(t) = \vartheta + \Delta\vartheta$$

3, 4, 5, 6].

[2,

Ω

$$\Omega \geq \varphi t$$

$$\varphi = 5...10^\circ, t = 1$$

$$\Omega = 5...10^\circ [2, 3].$$

$$V = 500 /$$

$$\varphi = 57,3V / D_{\min}$$

$$D_{\min} = 1000$$

$$\varphi = 11,46 /$$

50-70 %

3, 4, 5, 6].

$$\Delta q > \Omega_K$$

[2,

( .1).

130

94

[1, 2, 3]

3-5°

±5°

[2, 3, 4, 5, 6, 7].

[2, 3, 4, 5].

[2, 3, 4, 5, 6],

50-700

[2, 3, 3, 4, 5, 6].

2-3

( .5),

( .6).

[2, 3, 3, 4, 5, 6].

.7

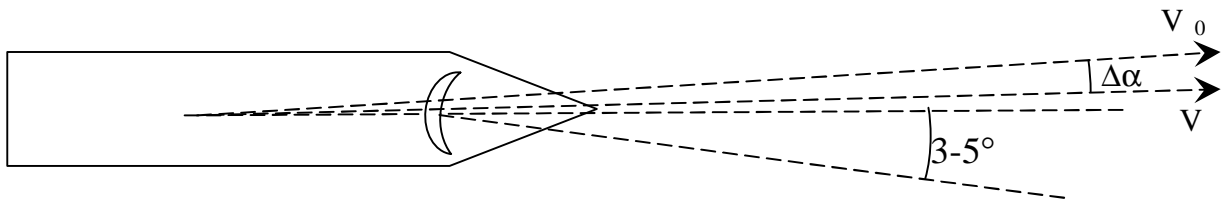

.4.

( )

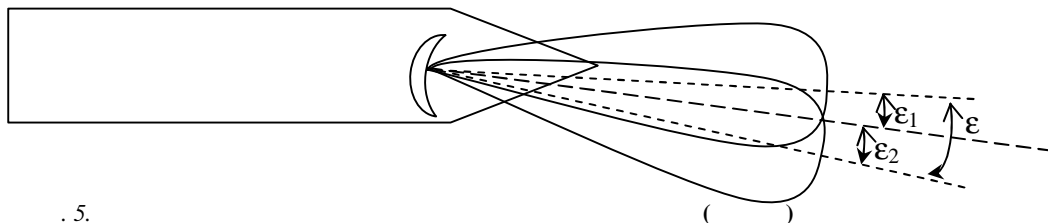

.5.

( )

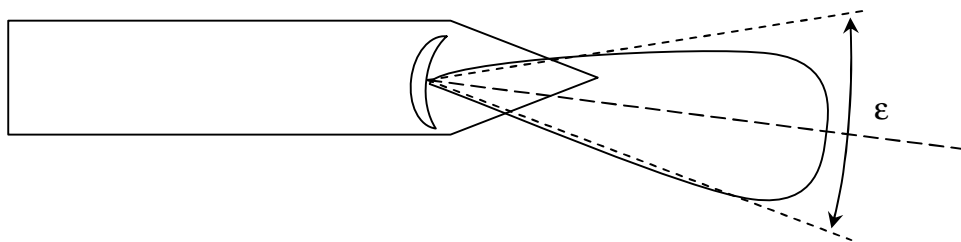

.6.

( )

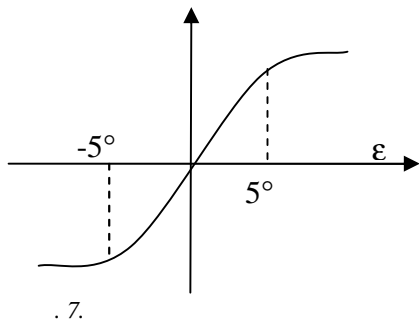

, 10-40 / .  
 , 10 / .

3000 F =30000

( . )

1. . . . .
2. , 1962. – 548 .
3. , 2003. – 368 .
- 2- . . . . / . . . . , 1989. – 336 c.
4. . . . . / . . . . , 2009. – 328 .
5. . . . . , 1962. – 752 .
6. . . . . / . . . . , 1968. – 680 .
7. . . . . / . . . . , 1963. – 376 .

21 .10.2010 p.

**SYSTEMS OF AIMING GUIDED SPINNING PROJECTILE**

V.O.Chumakevich, A.N. Droban, I.W. Puleko

*In the article suggestions are resulted in relation to the improvement of the system of aiming spinning projectile. Possibility of application of immobile radio engineering co-ordinator of purpose is considered with the special signals. It is also suggested to use an aiming head with the complexing of infra-red and radio engineerings signals.*

**Keywords:** Aiming, co-ordinator, radar, guided shell (rocket), aerial.